

POPULATION STRUCTURE AND MATING PATTERNS OF KILLER WHALES  
(*ORCINUS ORCA*) AS REVEALED BY DNA ANALYSIS

by

LANCE GODFREY BARRETT-LENNARD

B.Sc., University of Guelph 1980  
M.Sc., University of British Columbia 1992

A THESIS SUBMITTED IN PARTIAL FULFILMENT OF  
THE REQUIREMENTS FOR THE DEGREE OF

DOCTOR OF PHILOSOPHY

in

THE FACULTY OF GRADUATE STUDIES

(Department of Zoology)

We accept this thesis as conforming to the required standard

THE UNIVERSITY OF BRITISH COLUMBIA

December 2000

©Lance Barrett-Lennard 2000

In presenting this thesis in partial fulfilment of the requirements for an advanced degree at the University of British Columbia, I agree that the Library shall make it freely available for reference and study. I further agree that permission for extensive copying of this thesis for scholarly purposes may be granted by the head of my department or by his or her representatives. It is understood that copying or publication of this thesis for financial gain shall not be allowed without my written permission.

Department of Zoology

The University of British Columbia  
Vancouver, Canada

Date Dec. 20, 2000

## ABSTRACT

This thesis reports a genetic investigation of population segregation, social organization, and mating patterns in killer whales (*Orcinus orca*) of the northeastern Pacific Ocean. Previous studies identified two sympatric, non-associating populations, fish-eating *residents* and mammal-eating *transients*, and described many aspects of their demography, ecology, and social behaviour. Less is known about a third *offshore* population. Here, I focused on two aspects of killer whale social organization that are unusual among well-studied mammals: maintenance of complete segregation between residents and transients in sympatry, and lack of dispersal in individual residents of either sex.

I began by developing and testing lightweight pressure-propelled biopsy darts. They were an efficient way of acquiring skin samples from free-ranging whales and caused only minor behavioural responses in sampled animals. Using these darts and sampling stranded carcasses, colleagues and I collected biopsies from 269 individually-identified killer whales in British Columbia and Alaska. I used DNA from the biopsies to sequence the mitochondrial D-loop of 111 matriline, and genotyped all individuals at 11 polymorphic microsatellite loci.

I found that residents and transients are strongly differentiated genetically and that there is little or no gene flow between them. Both are divided into three genetically-differentiated regional subpopulations. Each resident subpopulation is more closely related to other resident subpopulations than to any transient subpopulation and vice versa, implying that the differences between residents and transients stem from a single divergence. The *offshore* population is not closely related to either of the other populations. The propensity of killer whales to live in fixed groups of a few hundred individuals apparently allows sympatric or parapatric populations to diverge genetically and could eventually result in speciation.

I examined mating patterns in residents by conducting paternity tests and analysing fixation indices based on microsatellite genotypes. I found that residents rarely mate within their pods. Further, in the most thoroughly-sampled resident subpopulation, most matings were between rather than within acoustic clans (groups of pods with similar acoustic repertoires). Because pods within clans proved to be closely related, inter-clan mating appears to be an inbreeding avoidance mechanism. Most matings were between individuals from the same subpopulation. This pattern of population segregation coupled with inbreeding avoidance closely resembles marriage patterns in many human societies.

## TABLE OF CONTENTS

ABSTRACT	ii
LIST OF TABLES	vii
LIST OF FIGURES	viii
PROLOGUE	ix
ACKNOWLEDGEMENTS	x
DEDICATION	xi
<b>CHAPTER ONE General Introduction</b>	<b>1</b>
Killer whale populations in the Northeastern Pacific Ocean	2
Previous molecular studies of killer whale populations	6
Study overview	7
Chronology of field work	7
Thesis organization	9
<b>CHAPTER TWO A Cetacean Biopsy System Using Lightweight Pneumatic Darts, and Its Effect on the Behaviour of Killer Whales</b>	<b>10</b>
Introduction	10
Methods	12
Darting system	12
Decontamination and sterilization	13
Sample processing and preservation	14
Killer whale biopsy sampling	14
Assessing disturbance	15
Humpback whale trials	16
Statistical analysis	16
Results	16
Killer whale sampling attempts	16
Factors affecting darting success	17
Immediate responses	18
Followup approaches	21
Description and utility of killer whale biopsy samples	22
Results of biopsy trials on humpback whales	23
Discussion	23

<b>CHAPTER THREE Genetic Analysis of Social Segregation Within and Between Sympatric Killer Whale Ecotypes</b>	26
Introduction	26
Methods	30
Study areas and biopsy procedures	30
Molecular analysis	30
Mitochondrial DNA	31
Microsatellites	31
Data analysis	32
Mitochondrial DNA	32
Microsatellites	33
Results	34
Biopsy samples	34
Mitochondrial DNA	34
Microsatellite DNA	36
Discussion	42
Residents and transient killer whales are reproductively isolated	42
The resident and transient populations are divided into genetically differentiated regional subpopulations	43
Fish-eating and mammal-eating killer whale traditions in the northeastern Pacific diverged once	44
Offshores are genetically differentiated from all known resident and transient subpopulations	45
Residents remain within their natal pods for life and have lower levels of genetic variation than transients	46
Sympatric origin of population subdivision	47
 <b>CHAPTER FOUR Mating Systems in Resident Killer Whales: Outbreeding Without Dispersal</b>	 50
Introduction	50
Methods	52
Biopsy sampling	52
Microsatellite analysis	53
Paternal exclusions	53
<i>F</i> -statistic analysis	54
Genetic distance and acoustic similarity correlation analysis	55
Results	56
Maternal and paternal assignments	56
Paternity matches within and between clans, pods and Subpopulations	57
Subpopulations	57
Clans	57
Pods	57
<i>F</i> -statistics	58
Correlation of acoustics and genetics	59

Discussion	62
Validity of association based inferences on maternity	62
Exogamy without dispersal	63
Pod fission and acoustic divergence	65
Mating patterns with respect to acoustic clan membership	65
Origin and function of acoustic clans	67
Subpopulation endogamy	68
Conclusions	69
<b>CHAPTER FIVE General Conclusions</b>	71
Biopsy system	71
DNA analysis	73
Social segregation within and between killer whale populations	73
Mating systems in resident killer whales	75
Summary and conclusions	78
<b>BIBLIOGRAPHY</b>	81
<b>APPENDIX 1</b> Mitochondrial D-loop sequences for resident, transient and offshore killer whales and for killer whales captured near Iceland.	91
<b>APPENDIX 2</b> Distribution of alleles at 11 microsatellite loci in seven subpopulations of killer whales from Alaska and British Columbia.	95

## LIST OF TABLES

Table 2.1	Immediate responses of killer whales to biopsy darting attempts, and percentage of dart hits that obtained biopsies.	20
Table 3.1	Identity, estimated size, and acoustic clan structure of known killer whale populations and subpopulations in the northeastern Pacific.	29
Table 3.2	Population, subpopulation, clan and pod identity of biopsied whales analysed in this study.	35
Table 3.3	Gene diversities and total number of alleles at 11 microsatellite loci in seven subpopulations of killer whales from Alaska and British Columbia.	39
Table 3.4	Weir and Cockerham (1984) estimators of F-statistics combined over 11 microsatellite loci for killer whale subpopulations from Prince William Sound, Alaska and British Columbia.	39
Table 3.5	Weir and Cockerham (1984) estimators of $F_{st}$ combined over 11 microsatellite loci for each pair of sampled subpopulations of killer whale from Prince William Sound and British Columbia.	40
Table 4.1	Overall $F_{is}$ , $F_{st}$ and $F_{it}$ estimators for resident killer whale pods, acoustic clans, and subpopulations from the northeastern Pacific Ocean, based on 11 microsatellite loci.	59
Table 4.2	Pairwise $F_{st}$ estimators based on 11 microsatellite loci for six acoustic clans of killer whales from the northern resident, southern resident and southern Alaskan resident subpopulations from British Columbia and Alaska.	60

## LIST OF FIGURES

Figure 1.1	Approximate distributions of the offshore population and resident subpopulations of killer whales in the northeastern Pacific Ocean.	3
Figure 1.2	Approximate distributions of transient killer whale subpopulations in the northeastern Pacific Ocean.	4
Figure 2.1	Assembled pneumatic dart, showing inserts of tailpiece and nosepiece into body tube, and location of barbed broach.	13
Figure 2.2	Detail of dart nosepiece and tip, showing barbed broach pressed into place.	13
Figure 2.3	Broach installation/extraction tool.	13
Figure 3.1	Maximum likelihood phylogram based on seven Pacific and two Atlantic killer whale mitochondrial D-loop haplotypes.	37
Figure 3.2	Maximum likelihood tree based on mitochondrial D-loop sequences for seven Pacific and two Atlantic killer whale haplotypes, including Risso's dolphin as an outgroup.	38
Figure 3.3	Unrooted neighbour-joining phylogram for Alaskan and British Columbian killer whales based on 11 microsatellite loci, using Nei's standard genetic distances.	41
Figure 4.1	Hierarchical population structure in resident killer whales.	52
Figure 4.2	Pairwise acoustic similarity index values versus microsatellite-based coancestry distances (Weir 1996) for resident killer whale pods belonging to a single acoustic clan.	61



## PROLOGUE

After completing undergraduate studies at the University of Guelph, my partner Kathy Heise and I moved to a lightstation on a small island just south of the British Columbian border with Alaska. One morning shortly after our arrival I rowed a few hundred metres offshore in a tiny dingy. The sea was unreasonably still, and I felt like nothing as much as an insect crawling across the surface of a painting. My reverie was shattered when six killer whales surfaced beside me, their blows cracking like rifle shots. As my heart crashed wildly, two of the huge animals circled an oar's distance from the dingy, turning on their sides to look up at me through the clear water. These were the first killer whales I had seen in the wild. Would they upset or swamp the dingy, either deliberately or accidentally? And if I ended up in the frigid water with them, what then?

But the whales never touched me. They bent their bodies and deflected their fins to avoid contact with the boat as they made a final pass underneath. Rocking in their wake, I watched them circle reefs and kelp patches and nose along cliffs as they moved away. They disappeared from sight long before their distant blows faded into the murmuring of the sea. As my apprehension drained away, questions came tumbling. What were the whales doing so close to shore? Was the group a temporary or long term association? Was it a harem? Were the whales foraging, and if so, for what? How did they find and catch their prey? Did they defend territory?

Many years and many killer whale encounters have passed since that day. The number of questions I have asked, and been asked, continues to grow—exponentially it seems. There is a joy in discovering answers of course, and a joy to be working in a field where every answer spawns more questions. I leave it to the reader to decide whether I've earned any of the first type of joy. Right now, both pale next to a third kind...the joy of putting one's dissertation to rest.

## ACKNOWLEDGMENTS

I was blessed throughout this project by the generous support and assistance of many people. Mike Bigg's tireless efforts laid the foundations for this project, the best legacy of all. He anticipated many of the results presented here—I wish he was here to share in them. Jamie Smith and John Ford were my academic supervisors. Their support, advice, and assistance at every turn is greatly appreciated. Graeme Ellis, Craig Matkin and Eva Saulitis were central to the field work, and continued collecting biopsy samples long after I retired to the lab. Kathy Heise, John and Bev Ford, Tom Smith, Volker Deecke, and Jane Watson were also of great assistance in the field. Martin Adamson served on my committee, and generously donated the use of his lab for the duration of my project. Rick Taylor provided encouragement and technical advice, and made me welcome in his lab as well. Sally Otto served on my committee, and helped immeasurably with data analysis and interpretation. Claire Thompson taught me everything I needed to know to begin working in a molecular lab. Theresa Burg and Valentina Mendoza assisted with lab work, and Shannon Bennett, Amanda Brown, Steve Connor, Tammy Laberge, and Allyson Miscampbell were my ever-helpful lab companions. I thank Andrew Trites, who encouraged me to take on the project when it was still a pipe dream; Peter Arcese, who suggested that I use pressure-propelled biopsy darts; Tom Smith, who served on my committee and whose efforts made the biopsy sampling possible; and Harald Yurk, who helped shape my ideas during our frequent brainstorming sessions. Fiona Buchanan and Jim Clayton provided microsatellite primers, and Dave Bain, Dave Nagorsen, Clint Wright, Anne Collet, and Eduardo Secchi provided tissue samples. Martin Adamson, Volker Deecke, John Ford, Kathy Heise, Wesley Hochachka, Kristin Kaschner, Beth Mathews, Craig Matkin, Sally Otto, Jamie Smith, David Westcott, and Harald Yurk reviewed manuscripts or chapter drafts. Others who helped included John Bagshaw, Jim and Mary Borrowman, John Carlson, Steve O'Brien and his lab, Terry Gjernes, Nick Georgiadis, Christophe Guinet, David Hoar, William Karesh, Bobby Lamont, Bill and Donna Mackay, Nancy Marcus, Beth Mathews, Meg Pocklington, Charley and Alice Ray, Anna Reid, Tiu Simila, Ruth West, and Mike Whitlock.

Funding for the lab and field work was provided by the Vancouver Aquarium Marine Science Centre's Killer Whale Adoption Program, the Exxon Valdez Trustee Council, and the North Gulf Oceanic Society. The Canadian Department of Fisheries and Oceans assisted in the collection of biopsy samples in British Columbia. Personal support funding was provided by the Natural Sciences and Engineering Research Council, the University of British Columbia, the Exxon Valdez Trustee Council, the North Gulf Oceanic Society and the Vancouver Aquarium Marine Science Centre.

## **DEDICATION**

This thesis is dedicated to my wife Kathy Heise for her incredible support and patience, and to my son Lee, who has taught me more about biology than I could have learned in a lifetime in graduate school.

## CHAPTER ONE

### General Introduction

Theodosius Dobzhansky (1973) made the now-famous observation that “nothing in biology makes sense except in the light of evolution”. The evolution he was referring to is driven by the action of natural selection and/or genetic drift on heritable variation, and is the bedrock on which modern biological thought is based. Since DNA is both the source of variation (via mutation) and the agent of inheritance, a logical (if not eloquent) corollary of Dobzhansky’s axiom is that the sense in biology is contained in DNA. Torturing this line of reasoning further (or putting aside all attempts at sophistry, simply browsing through recent issues of any biological journal) produces this principle: you may not have to know anything about DNA to know a lot about biology (witness Darwin), but it sure as hell helps.

This thesis is about social organization in the killer whale, seen through the x-ray glasses of DNA analysis. The study focuses on killer whale populations that reside in the coastal waters of British Columbia and southern Alaska, and builds on observational studies that identified most of the individual killer whales in the region (Bigg et al. 1987, 1990; Heise et al. 1992; Ford and Ellis 1999; Ford et al. 1994, 2000; Dahlheim 1997, Dahlheim et al. 1997; Matkin et al. 1999b). Further studies have described many aspects of their social behaviour and patterns of social affiliation (Ford 1989, 1991, Bigg et al. 1990, Matkin et al. 1999a, Morton 1990, Saulitis 1993, Deecke et al. in press), described their diet and foraging behaviour (Baird and Dill 1995, Barrett-Lennard et al. 1996a, Ford et al. 1998, Saulitis et al. 2000), and estimated their basic life history parameters (Olesiuk et al. 1990). These studies paint a picture of a highly social species characterised by long-term bonds between individuals, cultural transmission of dietary preferences and acoustic behaviours, unusual patterns of dispersal, and a complex system of socially-mediated sympatric and parapatric population subdivision. One of my main objectives in this study was to fill a conspicuous gap in this picture left by a near-complete absence of information about mating patterns. I also sought to describe the genetic consequences of killer whale social structure with a view to learning why it arose and how it is maintained.

## Killer whale populations in the Northeastern Pacific Ocean

Killer whales (*Orcinus orca*) are found in all of the world's oceans, and are most common in mid-to-high latitudes. The area of the world most conducive to their study is the western coast of North America from 48-61°N latitude, where they frequent coastal areas protected by offshore islands. In 1970 Michael Bigg, a research scientist at the Pacific Biological Station in Nanaimo, British Columbia, was given the task of estimating the number of killer whales inhabiting the southern part of this range. By 1981 Bigg had shown that two socially isolated sympatric groups of killer whales shared the coastal waters of British Columbia and northern Washington state (Bigg 1982). These groups, known as *residents* and *transients*, have been referred to variously as types, forms, races, or—the term I use here—populations. Bigg's findings stimulated great interest in the species and led to an ongoing series of field studies by government, university and independent researchers. This research has revealed that residents and transients specialize on fundamentally different prey—fish and marine mammals, respectively (Bigg et al. 1987, Ford and Ellis 1999, Ford et al. 2000). Many differences in the behaviour and social organization of residents and transients have also been described, most of which are probably attributable to their different diets (e.g. Bigg et al. 1987, Morton 1990, Baird et al. 1992, Barrett-Lennard et al. 1996a). For example Baird and Dill (1996) demonstrated that transients hunt seals most efficiently in coordinated attacks involving three whales (close to the mean group size they observed), whereas Ford et al. (1998) observed that much larger pods of resident killer whale forage on salmon while dispersed over several square kilometers. Similarly, Barrett-Lennard et al. (1996a) showed that residents produce social calls and echolocation sounds frequently while transients usually travel silently, and noted that this difference is likely accounted for by differences in the hearing sensitivities of fish and marine mammals.

The resident and the transient populations are each divided into at least three non-associating subpopulations (Figs. 1.1 and 1.2). In 1999, the *southern resident* and *northern resident* subpopulations had 82 and 214 members respectively (Ford and Ellis 1999, Ford et al. 2000); the *southern Alaskan resident* subpopulation was not completely censused but contained at least 360 individuals (Matkin et al. 1999a). The three subpopulations occupy

discrete adjacent ranges most of the time (Fig. 1.1), but occasionally pods from one population pass through the range occupied by another population. Intermingling of pods from different populations has not been seen on these occasions, although pods from the northern residents and southern Alaskan residents have been seen in close proximity (Dahlheim et al. 1997). In contrast, pods belonging to the same resident subpopulation frequently intermingle and engage in social behaviours.

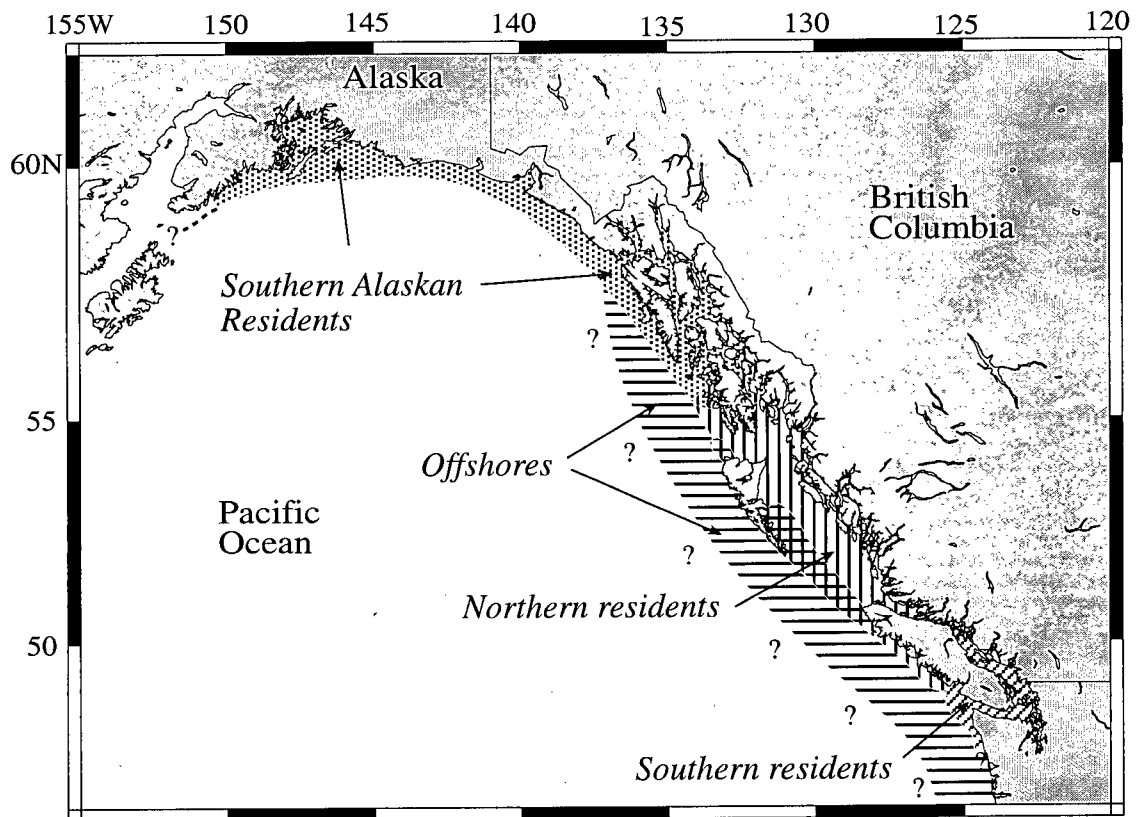

Figure 1.1 Approximate ranges of the offshore population and resident subpopulations of killer whales in the northeastern Pacific Ocean, based on Matkin et al. 1997, Matkin et al. 1999b, and Ford et al. 2000.

The three transient subpopulations that have been identified are also parapatric with respect to each other (Fig 1.2). In 1998 the *west coast transient* subpopulation had 219 members (Ford and Ellis 1999), the *ATI transient* subpopulation had 11 (Matkin et al. 1999b) and the *Gulf of Alaska* transient subpopulation was not completely censused but had at least 60 individuals (Ford and Ellis 1999). No association has been seen between any of these

subpopulations but, as with residents, members of a common subpopulation are often seen associating. A third population of killer whales was first identified in the late 1980's, and appears to frequent the outer part of the continental shelf (Fig 1.1). This group, referred to as the *offshores*, is poorly studied, but its diet is believed to include fish (Ford et al. 1994).

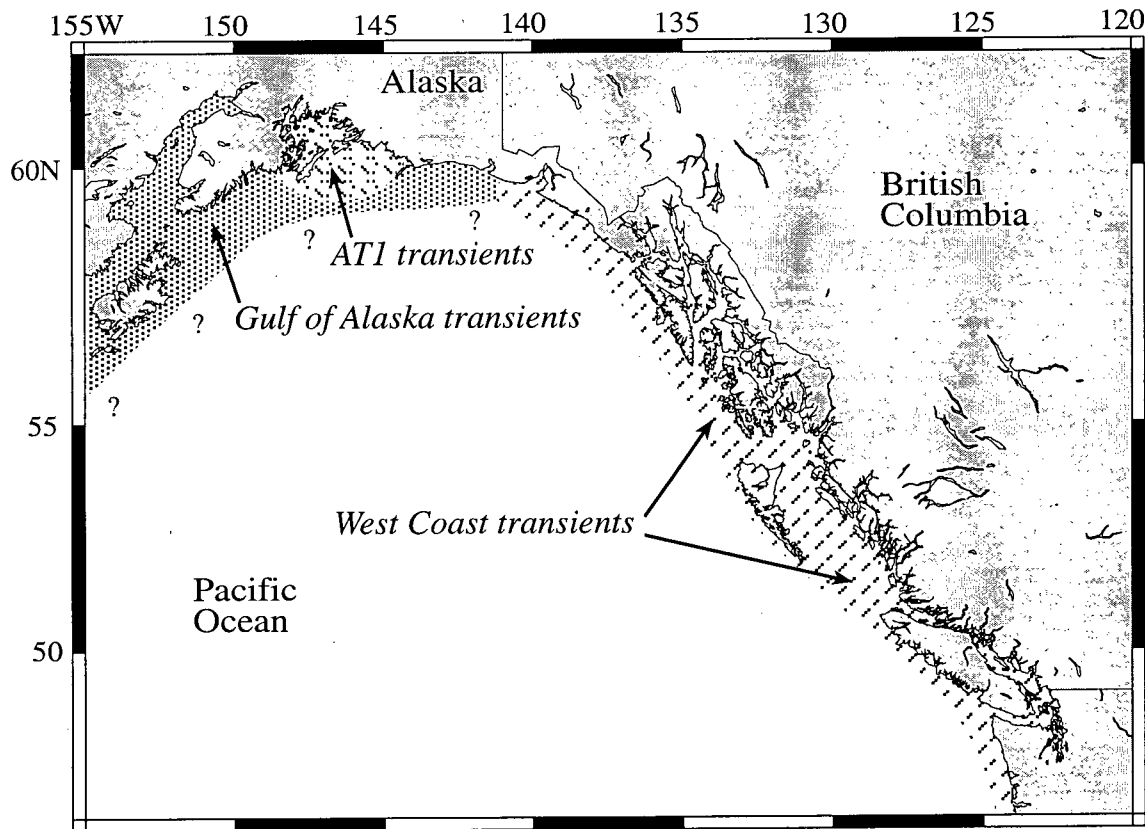

Figure 1.2. Approximate ranges of transient killer whale subpopulations in the northeastern Pacific Ocean, based on Barrett-Lennard et al. 1995, Ford and Ellis 1998, Matkin et al. 1999b. The western extent of the range of the Gulf of Alaska transients is conjectural—most sightings have been made between Kodiak Island and Prince William Sound.

Resident killer whales feed on salmon (*Oncorhynchus* spp.) in the summer months (Ford et al. 1998) and often spend weeks at a time in coastal areas, which has made them relatively easy to study. They live in matriline, groups containing up to three generations of maternal descendents of a single living or recently-deceased female—typically 3-6 individuals in total. The matriline is the fundamental social unit for resident killer whales and is remarkably stable—both males and females remain in their natal matriline for life (Bigg et

al. 1990). Matrilineal groups are also remarkably cohesive, with members almost always staying within acoustic contact of each other (Bigg et al. 1990). Some time after the death of a matriarch her daughters' matrilineal groups begin to slowly diverge from each other, spending more and more time apart. In this way matrilineal groups give rise to new matrilineal groups by splitting between groups, rather than by the emigration of individuals (Bigg et al. 1990). Pods are groups of matrilineal groups that frequently swim together, and typically contain 10-20 individuals. Because individuals do not disperse from their natal matrilineal groups, no immigration or emigration to or from pods occurs. It is likely that all of the matrilineal groups in a pod have descended from a single female ancestor that lived within the last few generations, implying that pods are a transitional stage in the slow divergence of matrilineal groups.

Resident pods can be distinguished readily by their unique repertoires of discrete calls (Ford 1989). However, some calls, or variations of calls, are shared between pods, making it possible to rank their acoustic similarity objectively (Ford 1991). Pods that share calls are considered members of the same *acoustic clan*; whereas members of different clans have no calls in common (Ford 1991). The southern and northern resident subpopulation have one and three acoustic clans respectively (Ford 1991); two clans have been identified in the southern Alaskan residents (Yurk et al. in prep). Clans do not cross the boundaries between resident subpopulations but they associate freely within each subpopulation (Bigg et al. 1990).

Transient killer whales live in groups of 1-6 individuals that are sighted less predictably than resident killer whales. These groups often contain a subgroup that is stable for many years as well as members that join the group for various periods. Some authors (e.g. Ford and Ellis 1999) restrict their use of the word *pod* to resident killer whales, to emphasize the extremely stable nature of the social groups in that population. However, no alternative term has been advanced for transient groups, and I use pod in its generic sense for both resident and transient killer whale social groups here. The reader should bear in mind, however, that resident and transient pods are distinctly different social entities.

Transient killer whales prey on marine mammals, principally harbour seals (*Phoca vitulina*), Dall's porpoises (*Phocoenoides dalli*), harbour porpoises (*Phocoena phocoena*), California



sea lions (*Zalophus californianus*) and Steller sea lions (*Eumetopias jubatus*) (Ford et al. 1998). They also kill seabirds on occasion, but these do not appear to be an important part of their diet. Transients use echolocation less frequently than residents (Barrett-Lennard et al. 1996a) and use fewer discrete call types (Ford 1984, Saulitis 1993). Transient pods do not appear to have unique repertoires, rather, a similar set of calls is used by most or all members of a subpopulation, and variants of some calls are shared between subpopulations (Ford 1984, Saulitis 1993). No equivalent of the acoustic clan of residents has been identified in transients. Since residents and transients are sympatric, they have been seen in proximity many times. During most of these observations, groups passed without incident, or one or both changed course to avoid the other (Morton 1990; Ford and Ellis 1999). Peaceful intermingling of residents and transients has never been documented, and on one occasion a large group of resident killer whales was seen to pursue and briefly attack a smaller group of transients (Ford and Ellis 1999).

#### Previous molecular studies of killer whale populations

Three DNA analysis-based studies of killer whale populations have been conducted prior to this one, all of which included killer whales from the northeastern Pacific Ocean.

(1) T.A. Stevens and colleagues published a comparison of mitochondrial DNA restriction fragment patterns from resident, transient and Atlantic killer whales using DNA from 19 stranded or captive killer whales (Stevens et al. 1989). The study identified 3 restriction fragment patterns, one common to 10 killer whales captured near Iceland, one to four northern residents and one southern resident, and one to two transients and two unidentified carcasses. The analysis provided the first evidence that sympatric resident and transient populations are genetically differentiated.

(2) A.R. Hoelzel compared mitochondrial D-loop sequences from thirteen captive or stranded carcasses, including northern and southern residents, transients, and Atlantic killer whales. The study corroborated Stevens et al.'s findings of differentiation between residents, transients, and Atlantic populations, and also found differences between northern and southern residents (Hoelzel 1991). Minisatellite banding patterns were also compared at one

locus; band-sharing coefficients were higher within than between the putative populations, with the exception of the southern and northern residents, which were approximately equal within and between (Hoelzel and Dover 1991).

(3) In a later study, Hoelzel and colleagues sequenced approximately 60% of the mtDNA control region (directly, or inferentially using single strand polymorphism analysis) in a larger set of northeastern Pacific killer whales, including 39 photo-identified individuals (Hoelzel et al. 1998). Their study suggested that female migration between residents and transients rarely occurs. It found no differences between the offshore and southern resident groups, and did not test for differences between putative sub-populations of transients. An analysis of three microsatellite loci on a subset of the samples found significant allele frequency differences between resident and transient assemblages. The levels of both mitochondrial and microsatellite variation were found to be low relative to other cetacean species.

#### Study overview

When I began my dissertation research, few DNA samples were available from killer whales from the northeastern Pacific, and fewer still could be attributed to specific individuals known from photo-identification studies. I designed and tested a biopsy darting system with the help of colleagues (see below) and used it to obtain skin samples from killer whales in the waters of British Columbia and the northern Gulf of Alaska. The identity of each whale was determined before it was biopsied; DNA was extracted from the biopsies using standard methods. I obtained DNA in this manner from 269 northeastern Pacific whales, and colleagues kindly supplied me with four additional DNA samples from Atlantic killer whales for comparison. I sequenced the entire mitochondrial DNA D-loop from one whale from each matriline, and typed every sample at each of 11 polymorphic microsatellite loci. I used the mitochondrial sequences to draw inferences about population structure and historic patterns of female dispersal, and the microsatellite genotypes to analyse mating patterns in residents. I constructed population phylogenies using both types of DNA marker, which provided insight into the origin of the resident/transient divergence. Finally, I used both

types of marker to test hypotheses concerning the formation of pods, acoustic clans, and subpopulations.

#### Chronology of field work

In 1992 (before starting my PhD work), I requested approval from the Canadian Department of Fisheries and Oceans to test a novel biopsy system on killer whales in British Columbia. With the help of my colleague Graeme M. Ellis I designed floating pneumatically-propelled biopsy darts by modifying a system developed for terrestrial mammals (Karesh et al. 1987). No systematic biopsy sampling of killer whales had been conducted previously, but work on other cetacean species demonstrated that most whales respond behaviourally when hit with a biopsy sampling projectile (e.g. Weinrich et al. 1992), and that injury (and presumably behavioural response) was directly related to striking energy (Patendaude and White 1995). Our principle concern therefore was to minimize both the weight and the firing velocity of the darts. A pilot project was approved, and Graeme Ellis and I tested the system in the summer of 1992. The tests were successful in acquiring skin tissue and provoked only minor behavioural responses, and we were given permission by the Department of Fisheries and Oceans and the University of British Columbia Animal Care Committee to begin systematically biopsy sampling killer whales in British Columbia in 1993.

Shortly after the biopsy work began in British Columbia Craig O. Matkin (North Gulf Oceanic Society, Homer, Alaska) and I applied to U.S. federal authorities for a research permit to biopsy killer whales in the Gulf of Alaska. We expected that approval would take several years, since the only permit awarded previously to biopsy killer whales in U.S. waters had generated great controversy (Anderson 1987) and had been revoked before it could be used. I planned to analyse the Alaskan samples as a postdoctoral research project after completing my Ph.D. To our surprise, the permit was approved quickly (presumably because the system had been successfully tested in British Columbia). Craig Matkin and I began collecting biopsy samples in the Prince William Sound and Kenai Fjords region of Alaska in 1994, and I incorporated the analysis of these samples into my Ph.D. research. Two other researchers (A.Rus Hoelzel and Marilyn.E. Dahlheim) also received a permit to use a slightly modified version of our system to biopsy killer whales in 1994, and have

focused their efforts in the southern part of the Alaskan panhandle region, between the two areas covered in this study (Hoelzel et al. 1998).

Biopsy sampling has now become a routine part of the research programs of both the Department of Fisheries and Oceans and the North Gulf Oceanic Society, and will, I hope, be continued well into the future so that long-term patterns of gene flow can be investigated. My own involvement in the field work began to wind down in 1997 so that I could focus on completing the laboratory part of the study, but Graeme Ellis and Craig Matkin continued collecting biopsy samples whenever possible. This dissertation is based on DNA from killer whales biopsied prior to 1999.

### Thesis organization

This thesis contains four chapters in addition to this one. Chapter Two describes the system that I used to collect biopsies from free-ranging killer whales, its effectiveness relative to earlier systems, and the behavioural reactions it caused. An earlier version has been published (Barrett-Lennard et al. 1996b). Chapter Three presents an analysis of social segregation within and between killer whale populations, and proposes a mechanism for population fission. A shortened version has been submitted for publication and is presently (Oct. 2000) in review. Chapter Four focuses on the mating system of one of the study populations, and discusses dispersal and the role of culturally transmitted traits in inbreeding avoidance. The main findings of the study are briefly summarized in Chapter Five.

## **CHAPTER TWO**

### **A Cetacean Biopsy System Using Lightweight Darts, and Its Effect on the Behaviour of Killer Whales**

#### **Introduction**

DNA analysis has become a vital tool in studies of cetacean phylogeny, population structure, and social organization (e.g. Amos et al. 1993, Baker et al. 1993). Similarly, toxicological analysis is a major component of many cetacean studies, particularly those focusing on the conservation of coastal or riverine species (e.g. Muir et al. 1990). Tissue samples for these analyses have been obtained opportunistically from stranded whales, (e.g. Murray et al. 1995), from those killed in whaling operations (e.g. Amos et al. 1993), and from the sloughed skin of living animals (Whitehead et al. 1990). Samples of skin and subdermal tissue have also been taken from free-ranging whales using biopsy sampling devices fitted to projectiles (e.g. Mathews et al. 1988). Sampling with projectiles has distinct advantages over other techniques: it provides fresh, uncontaminated tissue non-lethally, it can be used on species that strand rarely and do not slough skin, and it can be used to obtain samples from specific individuals known from photo-identification studies. The last factor is particularly useful when testing hypotheses about social systems using molecular analysis, or where it is desirable to control for age or sex in contaminant studies.

Most systems for sampling cetaceans use longbows or crossbows to fire bolts fitted with punch tips (e.g. Lambertsen 1987, Mathews et al. 1988, Palsbøll et al. 1991). The tips excise plugs of skin and retain them with internal barbs. In biopsy studies using bows to sample sperm and baleen whales, the percentage of shots hitting the target whale ranged between 42 and 81 percent, and 61 to 90 percent of hits obtained skin samples (Whitehead et al. 1990, Brown et al. 1991, Weinrich et al. 1991, Clapham and Mattila 1993, Brown et al. 1994). In a study using a large-bore pneumatic gun to biopsy humpback whales, Lambertsen et al. (1994) reported hits-per-shot and samples-per-hit rates of 95 and 88 percent respectively.

Most studies that have assessed the responses of cetaceans to biopsy sampling procedures have focused on immediate reactions visible at the surface, such as tail slashes, and on short term behavioral modifications, such as changes in swimming speed (e.g. Weinrich et al. 1992). These data serve as indicators of the relative invasiveness of different procedures, and of the relative effects of biopsy sampling on individuals of different ages and sexes. While useful for these purposes, they do not directly measure the absolute disturbance wrought by biopsy sampling. Subtle alterations in breathing pattern or swimming speed could be indicative of either minor annoyance or fear, and immediate or short term responses might or might not map onto longer term changes in behaviour. No studies have examined whether whales become more evasive of boats after they are biopsied. Weinrich et al. (1991) found that humpback whales used the same geographic areas before and after biopsies were taken, however no other studies have examined the effect of tissue sampling on the long-term movements of whales.

Here I describe the use of lightweight, untethered, pressure-propelled darts to obtain biopsy samples from individually-identified killer whales (*Orcinus orca*). To my knowledge, this type of system has not been previously used on cetaceans. I describe factors affecting its success in obtaining samples, histology of samples acquired, the whales' immediate responses to darting, whether responses differed among ages, sexes and populations, and whether short- or long-term avoidance of the research boat resulted from the biopsy procedures. Finally, I discuss the applicability of the sampling method to future studies requiring tissue samples from free-ranging cetaceans. Analyses in this paper are based on data collected in 1993, during my first field season of systematic biopsy sampling. I continued to use the system in subsequent field seasons but my focus was on acquiring samples efficiently, and I did not make detailed behavioural observations of the type reported here.

## Methods

### Darting system

The darting system was modified from a system originally developed for terrestrial mammals (Karesh et al. 1987). A diagram of an assembled dart is presented in Figure 2.1. The tip consists of a stainless steel tube with a honed internal bevel at one end and an external thread at the other. The tip screws into a nylon nose piece that acts as a stop to limit the depth of penetration. The nosepiece is pressed and glued into the dart body, a thin-walled tube of tempered, silicone-coated aluminium. A tailpiece of red polyethylene is pressed and glued into the other end of the body (tips and nosepieces custom machined, bodies and tailpieces supplied by Pseudart Inc., P.O. Box 1415, Williamsport, Pa. USA 17703). The dart floats upright with the tail projecting above the surface for maximum visibility. The tip is fitted with a barbed dental broach (coarse type, 22 mm. shaft length fitted to plastic handle, supplied by Canadian Dental Supply Ltd, 3900 North Fraser Way, Burnaby, B.C., Canada V5J 5H6), as shown in Figure 2.2. The plastic handle of the broach matches the inner diameter of the tip, and is pressed into place using the tool shown in Figure 2.3. The tool is also used to remove the sample from the tip by pressing the broach through the bevelled end of the tube. The total weight of an assembled dart is approximately 12 g.

Darts were fired from a variable-power dart projector (Pseudart Model 191). The projector uses blank .22 cal. charges (Omark type CCI 4C22) to pressurize a sealed chamber. Gas flows from this chamber through a power-adjusting valve to a rifled barrel containing the dart. At the three power ranges used during the study (settings '1', '2' and '3'), the dart velocities measured with a projectile chronograph 10 m from the rifle were 42, 52, and 74 m/sec respectively. The striking energies of darts fired at these ranges were calculated to be 10.6, 16.2 and 32.8 joules. I achieved an accuracy of 10 cm at a range of 15 m nine times out of ten when firing the darts on land.

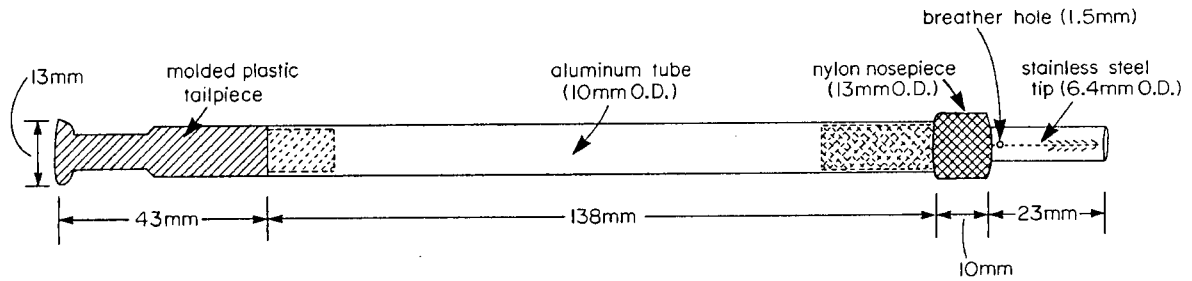

Figure 2.1 Assembled pneumatic dart, showing inserts of tailpiece and nosepiece into body tube, and location of barbed broach. (O.D. = outside diameter).

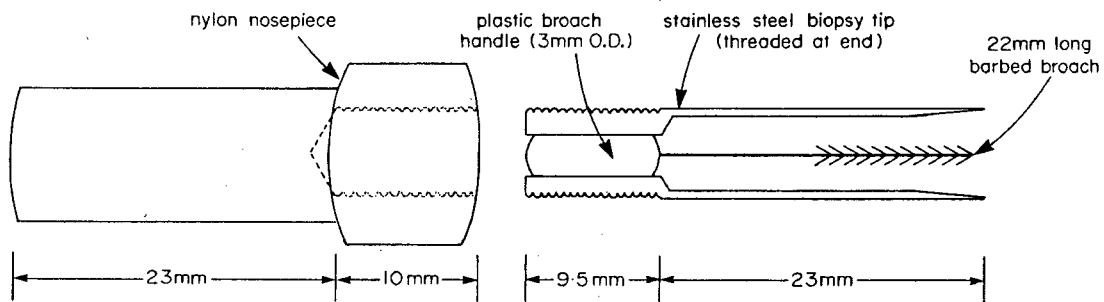

Figure 2.2 Detail of dart nosepiece and tip, showing barbed broach pressed into place.

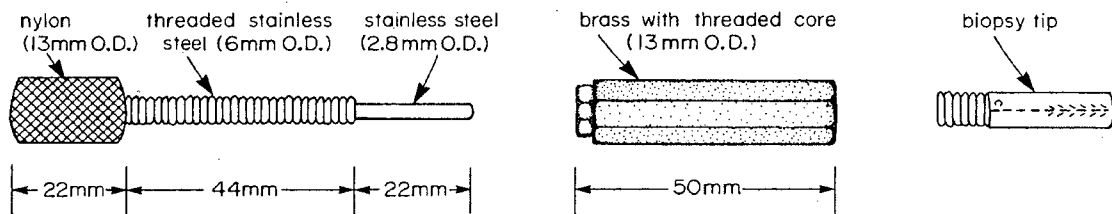

Figure 2.3 Broach installation/extraction tool. The dart tip threads into the right side of the brass body. The nylon-handled shaft threads into left side, and presses the barbed broach into place in the tip, or, by further advancement, pushes it through and out of the tip.

### Decontamination and sterilization

Prior to each use, I fitted a new dental broach into the dart tip, screwed it to the body tube, and flooded the assembled dart with acetone and then hexane. This procedure ensured that dart surfaces were sterile and free of substances that might contaminate the sample. I then swabbed the barrel with an acetone-soaked wad of cotton cloth to remove oil or other



contaminants and loaded the dart. After extracting a tissue sample from the dart, I washed the dart body, tip, and extraction tool with detergent and boiling water, rinsed them thoroughly, and allowed them to air dry.

#### Sample processing and preservation

After extracting the sample from the dart tip, I placed it in a glass dish, pulled the dental broach from the tissue, and sliced the sample transversely between the dermis and hypodermis. I preserved the outer portion for DNA extraction in 20% dimethylsulphoxide in a saturated salt solution (Amos and Hoelzel 1991), and stored it at 4°C. The inner portion of the sample was placed in a decontaminated glass vial and stored at -80°C for fatty acid and contaminant analyses.

I reserved a single biopsy sample for histological examination, and placed it in Davidson's solution immediately after removal from the biopsy tip. It was subsequently imbedded in paraffin wax, sectioned to 5 µ thickness, and stained with Harris' hematoxylin and eosin Y following standard histological procedures.

#### Killer whale biopsy sampling

Biopsy sampling was conducted along the coast of British Columbia, principally in the region extending from 50°40' N to 53°00' N. Killer whales from three putative populations were sampled: *residents*, which eat fish and live in groups of 10-50; *transients*, which feed on marine mammals and live in smaller groups; and *offshores*, a recently-discovered population with unknown diet and social structure (Ford et al. 1994). Most of the sampling attempts were conducted from an 8 m planing vessel with a cabin-top steering station for the driver / photographer (G.M. Ellis), and a sheltered cockpit aft that provided a stable platform for the darter (myself). Several darting attempts were also made from a 5 m inflatable boat powered by a 30 h.p. outboard motor, with the driver in the stern and the darter seated forward.

Killer whales were located by visually searching areas of known concentration and by listening for vocalisations with a directional hydrophone. Sighting reports from other mariners helped to focus searches. When found, whales were approached to 20 m on a

gradually converging course. Individuals were identified visually, by reference to Bigg et al. (1987), Ford et al. (1994) and to an unpublished catalogue of recent photographs (G.M. Ellis, unpubl. data). If the whales had not been previously seen that year, we took identification photographs of each individual present before beginning the biopsy sampling. We then selected a target individual based on a previously-established priority list, and waited, if necessary, for it to begin swimming and surfacing in a predictable and consistent manner. When this occurred, we paralleled the whale's course and approached to an estimated 8-20 m, while noting (1) its activity (categorized according to Barrett-Lennard et al. 1996a), (2) its position in relation to other group members, and (3) whether it adjusted its speed, course, or breathing pattern as we approached. When in position alongside the whale, the darter aimed at a point on the back approximately 30 cm below the trailing edge of the dorsal fin and fired when the whale arched its body just prior to diving. The dart, which bounced off the whale's skin after a strike, was retrieved from the water using a long-handled net. The whale was filmed prior to and during the darting attempt using a video camera.

#### Assessing disturbance

Notes were made on standardized data sheets regarding the estimated distance to the target whale at the time of darting, and on the type and extent of the reactions of the whale to both hits and misses. Additional details were added upon reviewing the video footage. Visible changes in the behaviour of killer whales in the vicinity were noted, and any changes in the position of the target animal with respect to other group members were also recorded.

Within 15 minutes of retrieving the dart from the water, we slowly re-approached the targeted whale, recording its breathing pattern, position in the group, and movements relative to the boat. The whale was approached to the same distance as in the darting attempt, unless it consistently avoided the boat. After 1-3 such approaches, we slowly moved away. If we sighted the whale again in the year following the darting attempt, we re-approached it in a similar way, while noting its behaviour and inspecting the site of the dart wound with binoculars.

### Humpback whale trials

To determine the effectiveness of the system in acquiring samples from larger whales and to obtain tissue for used by other researchers, we carried out a limited series of trials on humpback whales. We photographed the tail fluke of each whale prior to darting to ensure that we did not sample the same individual more than once. We then manoeuvred alongside the whale, and fired at a point approximately 50 cm below the dorsal fin from a range of 15-25 m.

### Statistical analysis

I analyzed the data using the SAS JMP statistical package, using logistic regression (Trexler and Travis 1993) and log-likelihood ratio contingency analysis (Zar 1996). Power analysis of one non-significant result was conducted using methods presented in Cohen (1988).

## **Results**

### Killer whale sampling attempts

I fired 91 darts in sampling attempts during 34 encounters with killer whales. The target whale was hit and skin and blubber samples were obtained in 59 of the attempts (65%). In 13 of the attempts (14%) the whale was hit but the dart was lost, empty, or contained only small fragments of epidermis ( $n = 4$ ,  $n = 4$ , and  $n = 5$  respectively). Whales were missed on 19 attempts (21%). Non-targeted whales were never hit. The percentage of darts fired that hit the animal and the percentage of hits that yielded samples were 60 and 72 percent respectively for the first 30 attempts, 87 and 90 percent for the second 30 attempts, and 90 and 93 percent for the final 31 attempts. Logistic regressions of the effect of attempt number on (1) the probability of a dart hitting and (2) the probability of a hit yielding a sample were both significant ( $\chi^2_1 = 15.39$ ,  $p < .001$ ;  $\chi^2_1 = 3.84$ ,  $p = 0.050$ , respectively).

I attribute much of the improvement in hit rate and sampling rate to the increasing experience of the darter and vessel driver. Incremental equipment modifications throughout the study also contributed to the efficiency of the system. For example, the .22 cal. charges that I used initially varied unpredictably in power; my hit rate improved when a different brand of charges was substituted after attempt number 15. Similarly, a dart sank and was lost

in an early attempt when the tailpiece detached; I prevented this from re-occurring by gluing as well as press-fitting the tailpieces to the dart bodies.

#### Factors affecting darting success

Killer whales were most readily darted when travelling at moderate speed, because they surfaced in predictable locations and arched their backs well above the surface when breathing, presenting relatively large targets. Resident killer whales that were foraging for fish in open water were unpredictable in their movements and I seldom attempted to biopsy them. However, when foraging for fish along cliffs and steep shorelines, residents moved in a more consistent way and could often be approached for darting. Resting killer whales tended to form tight groups and to consistently adjust their course so as to maintain distances of 25 m or more from the boat. Resting whales also showed little of their backs when surfacing, and after the first half of the field season I rarely attempted to approach or dart them.

I biopsy-sampled killer whales at estimated distances ranging from 5-25 m (mean 11.3 m). The probability of hitting a whale decreased as firing range increased (logistic regression  $\chi^2_1 = 14.27, p < 0.001$ ). At a range of 10 m the probability of hitting a targeted whale was approximately 92%, but by 15 m it fell to 65%. The probability of a hit yielding a sample was independent of range (logistic regression  $\chi^2_1 = 0.037, p = 0.847$ ).

Most animals that were not resting could be readily approached to a distance of approximately 15 m, but approximately 5% of the whales consistently adjusted their course and speed to remain further from the boat, regardless of their activity state. Most of these wary individuals were females, and all were estimated to be over 35 years of age (based on Bigg et al. 1990). Three were biopsy darted during the study, all at ranges over 20 m.

The probability that a dart would acquire and retain a skin sample was strongly influenced by the angle of impact. If the orientation of the whale was not perpendicular to the line of fire, or if the dart hit high on the back where the skin surface curved towards the dorsal ridge, the dart tended to glance off with no sample or with only a minute scraping of skin. Dart tips with both internal and external bevels were tested; the angle of impact was less critical with

internal bevels. In general, the angle of impact was least critical when the darts were extremely sharp.

Acute angles of incidence also appeared to increase the probability that a dart would remain attached to the skin rather than bouncing free. This occurred three times during the study and in each case the dart was lost. Twice I was able to see that the dart had fallen out within several minutes of the attempt, and once I was unable to determine how long the dart remained attached due to fading light. There was no evidence that the whales were aware of the attached darts. The length of the biopsy punch appeared to strongly influence the probability of successfully acquiring a skin sample. Several attempts were made with shorter (15 mm) tips, but these either failed to obtain samples, or, in one case, failed to bounce free of the whale. For a sample to be taken the biopsy plug must shear at the inward end; I suspect that this is most likely if the plug penetrates well into the blubber layer (see Patenaude et al. 1995).

I altered the power setting of the dart gun depending on the range of the whale. Early in the study I used a setting of 3 for whales that were >10 m from the boat, and a setting of 2 for closer whales. However, I noted subjectively that lower power/distance ratios caused milder immediate reactions by the whales, and also increased the probability that a dart would acquire and retain a tissue sample. By the midpoint of the study, I used power settings of 1, 2, and 3 for estimated whale distances of < 10 m, 10-15 m, and > 15 m. The darts dropped in flight more with low than with high power settings, but I compensated for this by adjusting the rifle sights.

#### Immediate responses

The immediate behavioural responses to darting attempts consisted of shaking, usually detected by quivering of the dorsal fin, and accelerating. If the shake or acceleration was momentary, ceasing before the whale submerged, the response was categorized as slight. Slight responses were often barely perceptible to the observers, and in some cases were only detected when reviewing the video film. Responses that continued as the whale submerged or that were in evidence on subsequent surfacings were categorized as strong.

The immediate responses of killer whales to biopsy darting attempts are presented in Table 2.1. In the resident population, I detected no significant difference in the immediate responses of mature males, mature females, and juveniles (log-likelihood ratio contingency test,  $G = 0.70$ ,  $df = 4$ ,  $p = 0.951$ ). Fewer transient than resident killer whales responded visibly to sampling attempts, however the difference was not supported statistically ( $G = 4.88$ ,  $df = 2$ ,  $p = 0.087$ ; test power = 0.77). The sample size of offshore whales was too small for meaningful comparison with the other populations.

Table 2.1 Immediate responses of killer whales to biopsy darting attempts, and percentage of dart hits that obtained biopsies.

Immediate Response ↓	Hits						Misses
	Residents			Transients	Offshores	All Whales	All Whales
	females over 14 yrs	males over 14 yrs	<14 yrs (both sexes)				
none visible	20 (3)	13 (5)	17 (2)	60 (3)	50 (1)	19 (4)	47 (9)
slight	73 (11)	82 (31)	67 (8)	40 (2)	50 (1)	74 (53)	21 (4)
strong	7 (1)	5 (2)	8 (1)			6 (4)	5 (1)
other			8 (1) <sup>a</sup>			1 (1)	26 (5) <sup>b</sup>
Biopsies per Hit →	80 (12)	79 (30)	92 (11)	80 (4)	100 (2)	82 (59)	

The first four rows show the percentage of animals in each population/age/sex category that exhibited the indicated response, followed by the sample size, in parentheses. The final row shows the percentage of biopsies acquired per hit, followed by the number of biopsy attempts that succeeded in acquiring samples, in parentheses.

<sup>a</sup> Whale looked back along its side, towards the dart impact site.

<sup>b</sup> Responses not documented.

Of four strong immediate responses to hits that were observed (Table 2.1), two consisted of acceleration followed by an increased swim rate, and two consisted of pronounced shakes that continued as the whales submerged, but ended before they resurfaced. The single individual that responded strongly to a miss was evasive prior to the attempt, and was known from photo-identification studies to be consistently difficult to approach.

Seven whales that were hit by a dart once but not biopsied were hit a second time. All were successfully biopsied on the second attempt, and no whales were hit more than twice. Five of the seven had slight immediate responses to the darts on both the first and second hit. One

had no response to the first dart but responded slightly to the second, and one reacted strongly to the first hit but only slightly to the second one.

Targeted whales that were swimming in formation with other whales were never seen to change their position with respect to other animals in their group immediately after darting attempts. On only one occasion was there evidence that non-targeted whales were influenced by the darting of a group member: two mature males gave distinct shakes when a female approximately 20 m from them was hit with a biopsy dart. The female was believed to be the mother of both males (based on Bigg et al. 1990).

#### Followup approaches

I attempted to re-approach whales that had been hit by biopsy darts after 68 of the sampling attempts. On 62 of these occasions the whale showed no tendency to change speed or course to avoid the boat, and was readily approached to 10-20 m. Four whales that were easily approached before being struck by a dart avoided the boat when re-approached, and two were evasive both before and after the strike. Of the seven whales that were hit twice, six were readily approached after both the first and the second hits. The seventh was evasive after both attempts.

After periods of one day to one year, I re-sighted and re-approached 46 of the whales that had been hit, including those that became evasive immediately after darting. None of these re-sighted individuals revealed a tendency to avoid the boat when approached to 10-20 m. In several cases the dart scar was visible as a black dot on the white saddle patch; no evidence of wound infection was seen. Most whales were darted and re-sighted in the same general areas, and there was no evidence that whales changed their travel patterns in response to darting.

I attempted to re-approach 12 whales within 15 min of missing them during a darting attempt. Seven were readily approachable, one became evasive after the miss, and four were evasive both before and after the darting attempt. During subsequent encounters I sighted and re-approached all but one of the whales that had been missed; no changes in approachability were noted.



### Description and utility of killer whale biopsy samples

Darts that had obtained samples were usually completely filled with tissue, and several mm of blubber extended from the open end of the tube. One sample of typical size weighed 0.50 g. Examination of histological sections of the tissue sample preserved in Davidson's solution revealed three primary layers: the epidermis, dermis and hypodermis. The epidermis consisted of heavily pigmented cuboidal cells originating in a basal papillary region. The cuboidal cells became more and more flattened towards the outer surface, and those at the surface appeared to be loosened and ready to slough away. Interdigitating invaginations and papillae formed the junction of the dermis and epidermis. The thickness of the epidermis, from the surface to the base of the papillae, was 4 to 6 mm. The dermis was composed of thick, interwoven bundles of collagen, and was well supplied with blood vessels. Some fat was present in the dermis, and became more prevalent as the dermis gave way to the hypodermis. Collagen fibers penetrated from the dermis into the hypodermis, creating a strong junction.

I extracted genomic DNA from 0.025 g subsamples of the epidermal and dermal tissue by proteinase K digestion, phenol-chloroform extraction, and alcohol precipitation, following procedures presented by Sambrook et al. 1989. DNA yields estimated by UV spectrophotometry (Sambrook et al. 1989) ranged from 20 to 210 ug ( $\bar{x} = 85$  ug,  $n = 40$ ), sufficient for multiple DNA analyses. A 20 mg portion of the hypodermis immediately underlying the dermis was provided to the Pacific Biological Station, Canadian Department of Fisheries and Oceans, where gas-liquid chromatography of derived metal esters of the constituent fatty acids was successfully used to provide fatty acid profiles (J. N. C. White, unpublished data). The remaining portions of the hypodermis were provided to the Institute of Ocean Sciences, Canadian Department of Fisheries and Oceans, for prominent contaminant analysis of dioxans, furans and P.C.B.'s. This analysis was conducted successfully using high resolution gas chromatography combined with high resolution mass spectrometry (Ross et al. 2000).

## Results of biopsy trials on humpback whales

Humpback whales were hit with biopsy darts 13 times; of these, 11 acquired samples of skin and blubber weighing approximately 0.5 g, and 2 glanced off the whales without acquiring samples. The immediate behavioural responses of the whales were stronger than those of killer whales, and consisted of a rapid dive, often preceded by a sideways tail slash, as reported by Brown et al. (1994).

## **Discussion**

The system described here differs from previous cetacean biopsy systems in three principal ways. (1) It uses darts that are both smaller and lighter than previous biopsy projectiles. Based on their descriptions, projectiles used in other systems weigh between 50 and 350 g, a minimum of four times the weight of the darts used here. (2) Barbed dental broaches are used to retain tissue samples, unlike the inward-facing prongs (e.g. Winn 1973), central hooks (e.g. Brown et al. 1991), or hinged flaps (Aguilar and Nadal 1984) used previously. (3) The system uses a pneumatic rifle to propel untethered, floating darts, whereas previous rifle systems have used retrieval lines (Winn 1973, Kasamatsu et al. 1991, Lambertsen et al. 1994).

A primary objective in designing the darts was to minimize disturbance and wounding caused by the biopsy strikes. Evidence that the striking energy of biopsy projectiles can significantly affect the severity of wounds in belugas (*Delphinapterus leucas*) was presented by Patenaude and White (1995). I used a dart that was low in mass to minimize the energy transferred to the whale by biopsy strikes. The small surface area of the darts was intended to limit the influence of cross winds and air friction on the flight of the dart, so that predictable trajectories could be achieved at low firing velocities. Despite the weight and size reductions, the dart impact energy was sufficient to excise tissue and recoil free of the skin surface. I had no reason to think that still smaller darts would not have been equally effective, and recommend that further size reductions be tested in future studies.

The barbed broaches were lightweight and provided a convenient way for ejecting the samples from the biopsy tips. Also, because the broaches were sterile when installed and

each was used only once, there was no concern that retention of tissue or other material on the barbs might contaminate subsequent samples (Karesh et al. 1987). However, because the darts occasionally hit without acquiring a sample, it would be useful to experimentally compare the effectiveness of broaches and central hook tissue retainers (e.g. Brown et al. 1991).

The pneumatic rifle used in this study is smaller and simpler to handle than either a longbow or crossbow, and due to the rifling of the barrel, is probably inherently more accurate. Accuracy in biopsy darting is more important for delphinid cetaceans such as killer whales than it is for the baleen or sperm whales that have been the subjects of previous systematic efforts. As well as being relatively small targets, delphinids frequently travel in tight groups, and inaccurately-fired darts could put non-targeted individuals at risk. The percentage of firings resulting in hits and the proportion of firings that acquired samples during the final two thirds of the study, 89% and 81% respectively, compared favourably with those of experienced researchers biopsy sampling humpback whales with crossbows (75% and 68% for Brown et al. 1994; 81% and 71% for Weinrich et al. 1991). The highest biopsy sampling rates for humpback whales reported to date, 88% hits per firing and 83% samples per firing, were achieved in a study using a pneumatic gun to propel arrows (Lambertsen et al. 1994).

Tether lines were not used in this study because I was concerned that they would reduce the accuracy of the darts and might increase the disturbance they caused. Weinrich et al. (1991) and Whitehead et al. (1990) reported adverse reactions to tether lines that entangled the flukes or fell across the backs of humpback and sperm whales. I found that darts were easy to locate, and would only recommend the use of tethers if sea conditions or the nature of the research vessel made the retrieval of floating darts difficult.

As in previous studies (Mathews 1986, Weinrich et al. 1991), the darting success rate increased progressively throughout the study. This improvement resulted from the increasing experience of the darter and the vessel operator, and from refinements to the equipment made throughout the study. This trend continued beyond the trials described here. In the field season subsequent to the one reported in this chapter, I acquired samples from 88% of the 42 darts fired, and from 97% of the darts that hit. I therefore recommend

that researchers starting similar projects use experienced personnel when possible, and begin with modest sampling objectives until the biopsy procedures are well practised.

The immediate responses of killer whales to the darts appeared to be minor, since behavioural activities were not interrupted as a result of darting. In most cases, there was no indication that darted whales became evasive of the research boat in either the long or short term. This may reflect either the mild nature of the darting stimulus, or it may indicate failure of the whales to associate the pain of a biopsy dart with the presence of the boat. Most of the whales that reacted strongly to the dart were evasive prior to the attempt, suggesting that these individuals may have had negative experiences with boats in the past. Prior to the 1970's it was not uncommon for mariners to shoot at killer whales in British Columbia (G.M Ellis, pers. obs.). Three of the four animals that reacted strongly to a dart and the single animal that reacted strongly to a miss were estimated to be more than 35 years of age (Bigg et al. 1987). Resting whales were relatively difficult to dart, for the reasons described above. Furthermore, based on previous experience photo-identifying killer whales and on my observations during the present study, I believe that killer whales are most easily disturbed when resting and that biopsy sampling is least invasive when it is conducted on actively swimming whales.

## CHAPTER THREE

### Genetic Analysis of Social Segregation Within and Between Sympatric Killer Whale Ecotypes.

#### Introduction

The development of reproductive isolation is the critical step in speciation. Ernst Mayr (1942) argued that a period of allopatry was a strict requirement for speciation. This view has gradually changed, and the list of conditions that could initiate or reinforce sympatric speciation is growing, as is the list of species divergences that likely occurred sympatrically. Sister species that are considered good candidates for sympatric speciation generally retain overlapping ranges and are distinguished by morphological differences related to ecology and/or mating. It is inherently difficult to identify sympatric divergences at an early stage, before obvious morphological differences have evolved. Not surprisingly, the search for genetic subdivision in natural populations has nearly always been a search for physical barriers to migration.

In only two mammal species that I am aware of, humans and killer whales, is there evidence of sympatric populations that are morphologically similar but socially distinct. In humans, ethnic groups have coexisted for many generations without fusing (Guglielmino 1996). Gypsies, for example, have persisted in the midst of other European groups for centuries. Killer whales, the focus of this study, were shown by Bigg (1982) to live in two sympatric but socially isolated populations along the coast of British Columbia and adjacent areas. Numerous demographic and behavioural studies of killer whales followed Bigg's discovery (e.g. Ford 1989, Bigg et al. 1990, Ford 1991, Baird and Dill 1996, Barrett-Lennard et al. 1996a, Matkin et al. 1997, Deecke et al. 1999). These studies identified individuals based on natural markings, and focused on association patterns and behaviour. It is now evident that the sympatric populations, referred to as *residents* and *transients*, are distinct ecotypes that differ in feeding ecology, behaviour and social organisation (Ford et al. 1998, 2000; Ford

and Ellis 1999). They are also differentiated at both mitochondrial and nuclear genetic loci (Stevens et al. 1989, Hoelzel 1991, Hoelzel et al. 1998).

Residents prey on fish, principally salmonids; they occasionally harass marine mammals but have not been seen to eat them (Ford et al. 1998). Resident social organization is highly structured. Individuals travel throughout their lives in *matrilines*, comprising a matriarch and her complete lineage, both male and female. Matrilines usually contain 4-12 individuals from two to four generations, and often travel in association with other matrilines. It is believed that they associate most often with matrilines with which they share recent maternal ancestors (Bigg et al. 1990). Groups of frequently-associating matrilines are known as *pods*. The largest unit of social structure is a set of associating pods that share a common range. Bigg (1982) and subsequent authors referred to this unit as a *community*; I refer to it here as a *subpopulation*. Each resident pod uses a distinct set of stereotyped calls, or *dialect*; pods with related dialects make up an *acoustic clan* (Ford 1991). Pods associate freely both within and between acoustic clans within their subpopulation but do not associate with pods from other subpopulations (Bigg et al. 1990).

In British Columbia, two subpopulations of residents have been studied since 1972. The *southern resident* subpopulation contains a single acoustic clan and is most commonly sighted near the southern part of Vancouver Island. The *northern resident* subpopulation contains three clans and is usually sighted in coastal waters ranging from the central part of Vancouver to southern Alaska. A third subpopulation known as the *southern Alaskan residents* has been studied since 1984 (Leatherwood et al. 1990) and is commonly sighted in the northern Gulf of Alaska. It contains at least two acoustic clans (Jurk et al. 1998). Most resident pods are sighted much less frequently in winter than in summer but in the same general areas. A recent winter sighting of two southern resident pods in Monterey Bay, California was a notable exception (N.A. Black, pers. comm.). The approximate size and distribution of each of the resident subpopulations are presented in Table 3.1 and Figure 1.1 respectively.

Transient killer whales live in pods of 1-6 individuals and prey on marine mammals, principally seals, porpoises, and sea lions; they occasionally kill seabirds but have not been

seen preying on fish (Ford et al. 1998). The membership of a transient pod is often stable for long periods but individuals occasionally disperse between them (Ford and Ellis 1999). As with residents, the transient population is divided into subpopulations with discrete ranges. Studies of transient dialects are at an early stage, and no equivalent of the acoustic clans seen in residents has been identified. It appears that a similar set of calls is used by all or most members of a subpopulation and that some calls may be shared between subpopulations (Ford 1984; Saulitis 1993).

The best-known transient subpopulation, the *west coast transients*, ranges along the coast from Glacier Bay, Alaska, to central California (Goley and Straley 1994, Ford and Ellis 1999). A second, smaller subpopulation referred to as the *AT1 transients* has only been sighted in and near Prince William Sound and Kenai Fjords, Alaska. A third, poorly-known subpopulation known as the *Gulf of Alaska transients* inhabits waters west of Glacier Bay. These whales enter Prince William Sound and Kenai Fjords on occasion but have not been seen to associate with the AT1 transients. The western extent of the Gulf of Alaska transient's range is unknown. It is rarely seen near the coast, except in exposed areas. The approximate sizes and distributions of the transient subpopulations are given in Table 3.1 and Figure 1.2 respectively.

Recently, a third putative population of killer whales referred to as the *offshores* has been identified (Table 3.1, Figure 1.1). Little is known about this assemblage, other than that it contains at least 200 individuals, is usually sighted 20 km or more off the coast, ranges between California and the southern tip of Alaska, and typically travels in groups of 20 or more individuals (Ford et al. 1994). Hoelzel et al. (1998) found no differences in the mitochondrial DNA sequences of offshores and southern residents.

Table 3.1. Identity, estimated size, and acoustic clan structure of known killer whale populations and subpopulations in the northeastern Pacific.

Population	Subpopulation	Abbrev.	Acoustic Clans	Size	Source
Resident	Northern	NR	A, G, R	214	Ford et al. 2000
	Southern	SR	J	82	Ford et al. 2000
	Southern Alaskan	SAR	AB, AD	360+	Matkin et. al. (1999a)
Transient	West Coast	WCT		219	Ford and Ellis (1999)
	Gulf of Alaska	GAT		60 +	Ford and Ellis (1999)
	AT1	AT1		11	Matkin et al. (1999)
Offshore		OFF		200+	Ford and Ellis (1999)

Sources are given for population size estimates. Acoustic clans of northern and southern residents described by Ford (1991), and of southern Alaskan residents by Yurk et al. (in prep.). In subpopulations that have not been completely catalogued, the number of identified animals is followed by “+”.

This paper reports a comprehensive genetic analysis of population segregation in killer whales off the west coasts of British Columbia and Alaska. My objectives were to: (1) re-examine the extent of reproductive isolation between residents and transients, (2) determine the extent of reproductive isolation between putative subdivisions of each population, (3) ask whether the resident/transient separation occurred once or multiple times, (4) determine the population status of the offshore group of killer whales, (5) determine whether resident killer whales remain permanently within their natal groups as suggested by field evidence, and (6) compare the levels of genetic diversity in residents and transients. The study is based on the analysis of DNA from skin biopsies of 269 photo-identified killer whales from British Columbian and Alaskan waters, including members of most known resident matriline.



## Methods

### Study areas and biopsy procedures

I conducted the biopsy sampling in collaboration with G.M. Ellis (Canadian Department of Fisheries and Oceans) and C.O. Matkin (North Gulf Oceanic Society, Homer, Alaska). We concentrated the biopsy sampling effort in two areas: in and around Prince William Sound and Kenai Fjords, Alaska (59°30'-61°0'N, 146°15'-151°0'W), and from northern Vancouver Island to Caamaño Sound, British Columbia (50°45'-53°0'N, 127°0'-129°45'W). We also biopsied whales near Langara Island (54°14'N, 133°0'W) and in the western Strait of Georgia (49°15'N, 123°42'W). To locate whales, we visually searched areas where killer whale sightings were common by scanning with binoculars from a 8-m boat and from high points on shore. We also listened for vocalizations with a directional hydrophone. Mariners often reported whale sightings to us by marine radio, helping us to focus searches.

When killer whales were sighted, we photographed as many individuals as possible for positive identification later (using identification catalogues by Bigg et al. 1987, Heise et al. 1992, Ford et al. 1994, Dahlheim 1997, Dahlheim et al. 1997, Ford and Ellis 1999, Matkin et al. 1999b, and unpublished data held by G.M.E.). We then used lightweight pneumatic darts (Chapter 2) to biopsy individuals that we could identify visually, simultaneously re-photographing those with subtle distinguishing features. First priority was given to members of matrilineages that had not been sampled previously. Skin from the biopsy samples was preserved in dimethylsulphoxide and NaCl (Amos and Hoelzel 1991). Blubber from the biopsies was preserved separately for contaminant analysis (results in Ross et al. 2000).

### Molecular analysis

To extract DNA, I homogenized 30 mg of skin in a glass tissue grinder, digested it with proteinase K for 24 h at 54°C, purified the DNA with phenol and chloroform, and precipitated it with ethanol using standard procedures (Sambrook et al. 1989). Care was taken to prevent cross-contamination by using sterile disposable labware, flame- or acid-sterilizing non-disposable items, and using aerosol-filtered pipettor tips during all procedures. The purified DNA was dissolved in TE buffer, and the approximate

concentration of DNA in this stock solution was determined with UV spectrophotometry (Sambrook et al. 1989). The DNA stock was stored at -80°C. I made a working solution of each sample by diluting a portion of its stock solution in water to a DNA concentration of 50 ng/ul. This working solution was stored at -20°C and was replenished as required from the stock. DNA extraction and polymerase chain reaction (PCR) preparations were performed in a room off-limits to amplified PCR products.

#### *Mitochondrial DNA*

I selected one individual for mtDNA sequencing from each matriline (based on Ford et al. 1994 and Matkin et al. 1999a). I used the polymerase chain reaction (PCR) to amplify the entire D-loop region using custom-designed primers based on Commerson's dolphin and fin whale sequences (Southern et al. 1988, Arnason et al. 1991) annealing to the tRNA-Thr and 12s-rRNA regions), purified the samples with QIAQuick® spin columns and protocols supplied by Qiagen, Ltd., ran sequencing reactions using Fs-Taq® system reagents and protocols supplied by Applied Biosystems, Ltd., and resolved the sequences using an Applied Biosystems 377 automated DNA sequencer. Because the sequence was too long (950 bases) to be resolved in one direction, I ran sequencing reactions from each end of the amplified fragment. I visually checked the graphs of nucleotide order and band strength from the automated sequencer and corrected the computer-generated sequences accordingly. I also used the approximately 400-base overlap in the sequences of opposite directions to check for errors. As a final accuracy check, I confirmed differences between sequences from different individuals by comparing their sequencer graphs. I then aligned unique sequences using the program CLUSTAL-W (Thompson et al. 1994).

#### *Microsatellites*

I tested 27 primer sets developed for microsatellite analysis in cetacean species (Amos et al. 1993, Buchanan et al. 1996, Richard et al. 1996, Valsecchi and Amos 1996, Hoelzel et al. 1998) for their ability to amplify microsatellite loci in killer whales. In this testing process, I ran low-stringency PCR reactions (Innis and Gelfand 1990), electrophoresed the PCR products on 1.2% agarose gels, stained them with ethidium bromide, and photographed them under UV light. When a given primer set produced an amplified product that was similar in

size to that described in its original study, I used an empirical optimization procedure (Innis and Gelfand 1990) to improve the selectivity and yield of the reaction. To visualize the amplified DNA with greater precision, I 1) end-labeled one of the primers with  $^{33}\text{P}$  by incubating 50 pmol of the primer with polynucleotide kinase (PNK) and 10 uCi [ $\gamma$ - $^{33}\text{P}$ ]ATP following protocols supplied by New England Biosystems Ltd, 2) performed PCR under the optimized conditions using 1 pmol of labeled primer, 2.5 pmol of the same primer unlabeled, and 6 pmol of the reverse primer, 3) resolved the PCR products on a 0.4 mm X 30 cm X 40 cm denaturing gel containing 5% polyacrylamide, and 4) dried the gel on filter paper and exposed it to autoradiograph film for 12 to 96 hours. I identified microsatellite DNA on the developed film by the presence of characteristic shadow bands (Hauge and Litt 1993) and determined allele sizes by comparing the bands to reference DNA sequences run on every gel.

I initially tested each pair of primers on DNA from 40 killer whales that I believed to be distantly related, including resident and transient individuals from both British Columbia and Prince William Sound. Those primer pairs that produced clear microsatellite bands and that revealed at least three different alleles in the test group were used to type all biopsied killer whales. During the routine typing at each of the selected microsatellite loci, samples that failed to amplify or that produced ambiguous bands on the gel were amplified a second and if necessary a third time. I scored the alleles manually by comparison to the reference sequence. As a check, I re-scored each film several days later and compared the two sets of scores. Errors were corrected by this method in approximately 1% of the scores. As an additional check of the consistency of scores, I re-amplified a minimum of 5% of the samples at each locus and scored them two more times. No differences were found between scores in the first and second amplification.

### Data analysis

#### *Mitochondrial DNA*

I inferred historical relationships among the haplotypes using a branch-and-bound search algorithm to find optimal trees based on a maximum-likelihood criterion (Swofford et al. 1996); calculations were performed using PAUP\* version 4.0b2a, (Swofford 1998). The

maximum likelihood analysis used nucleotide frequencies and transition/transversion ratios based on the sequences. I repeated the analysis on 100 bootstrapped versions of the data to determine support for the tree topology.

### *Microsatellites*

I grouped the data based on population subdivisions suggested by observational data (Bigg et al. 1990, Ford et al. 1994, Barrett-Lennard et al. 1995), the mitochondrial analysis described above, or both. The offshores were treated as a seventh subpopulation. Using microsatellite genotypes from the group with greatest sample size, I tested each locus for evidence of heterozygote deficiency using Guo and Thompson's (1992) Markov chain method as implemented in GENEPOP (Raymond and Rousset 1995). An unbiased estimate of gene diversity ( $H_e$ ) was calculated for each locus in each subpopulation using Nei and Roychoudhury's formula, (in Nei 1987). To compare gene diversities between residents and transients, I used a nested two-way ANOVA, with population and locus as factors and with subpopulations nested within populations. I also calculated Weir and Cockerham's (1984) estimators of Wright's  $F$ -statistics for the subpopulations using the program FSTAT 2.8 (Goudet 1995). To determine 95% confidence intervals for the estimates, I performed 1000 bootstraps by resampling among loci.

I calculated Nei's standard genetic distance  $D_s$  (Nei 1972) between all putative subpopulations using MICROSAT 1.5 (Minch et al. 1995).  $D_s$  does not assume any particular mechanism of mutation, unlike measures that assume that mutation occurs in a stepwise fashion (e.g.  $\delta\mu^2$ , Goldstein et al. 1995). Stepwise mutation-based measures are expected to be linear with respect to time at phylogenetic time scales, whereas  $D_s$  is a more appropriate measure when divergences have taken place recently and genetic drift, not mutation, is the main force creating differentiation (Goldstein et al. 1995, Paetkau et al. 1997). The genetic distance matrix was used to construct a neighbour-joining (Saitou and Nei 1987) tree, using the NEIGHBOR subroutine in PHYLIP 3.5c (Felsenstein 1993). To determine support for the tree topology I used MICROSAT to bootstrap the allele frequency data 1000 times by resampling among loci and to calculate distance matrices for each

bootstrapped data set. NEIGHBOR and CONSENSE subroutines in PHYLIP were then used to determine the percentage of bootstraps supporting each part of the tree.

## **Results**

### Biopsy samples

My collaborators and I biopsied 261 identified killer whales off British Columbia and southern Alaska, and obtained tissue from the stranded carcasses of eight additional identified individuals. The sampled whales were from 111 known matriline and included offshores and members of each resident and transient subpopulation. In addition, colleagues supplied tissue samples from four killer whales from the Atlantic ocean. The population, clan and pod membership of the sampled whales are listed in Table 3.2.

### Mitochondrial DNA

A total of 130 killer whales were sequenced, including at least one from each sampled matriline from British Columbia and Alaska and four individuals from the Atlantic. I identified 11 variable sites in the Pacific Ocean sequences, comprising one single base-pair insertion/deletion, nine transitions, and one transversion; the Atlantic killer whales added one additional transition. These 12 variable sites defined seven haplotypes among the Pacific whales (Appendix 1).

Northern and southern residents, AT1 and west coast transients, and offshores were each monomorphic and had different haplotypes. Southern Alaskan residents had two haplotypes, one matching southern residents and the other northern residents; pod members always shared a single haplotype, but pods with different haplotypes were frequently seen in close association. The Gulf of Alaska transients also had two haplotypes, one found in all samples from three pods, the second in both samples from a single pod. Two haplotypes were found in Atlantic whales. One was from a whale that stranded in southern Brazil, the other from two whales captured near Iceland and one that stranded in western France. An unrooted maximum likelihood phylogram based on the D-loop sequence data is presented in Figure 3.1. The transient subpopulations were an outgroup to all others, including Atlantic whales. I repeated the mitochondrial analysis with the addition of a Risso's dolphin

Table 3.2. Population, subpopulation, clan and pod identity of biopsied whales analysed in this study.

Population	Putative Subpopulation <sup>1</sup>	Acoustic Clan	Pod			
Resident (216)	Southern Resident (8)	J (8)	J1 (7)			
			L1 (1)			
			A1 (17)			
	Northern Resident (126)	A (75)	A4 (10)			
			A5 (15)			
			B1 (8)			
			C1 (8)			
			D1 (4)			
			H1 (5)			
			I1 (1)			
			I2 (3)			
			I18 (4)			
			G (34)	G1 (7)		
			G12 (7)			
			I11 (14)			
I31 (6)						
R (17)	R1 (15)					
W1 (2)						
Southern Alaskan Resident (82)	AB (44)	AB (14)				
		AG3 (3)				
		AI (6)				
		AJ (12)				
		AN (8)				
		AX (1)				
		AD (38)	AD5 (4)			
			AD16 (4)			
			AE (15)			
			AK (12)			
		AS (3)				
Offshore (7)	[British Columbia & SE Alaska] (7)					
Transient (46)	West coast transient (30)	Gulf of Alaska transient (8)	AT1 transient (8)			
Atlantic (4)	[West coast of France] (1)	[Iceland] (2)	[Southern Brazil] (1)			

Numbers of samples in each category in round brackets. Pod designations based on Heise et al. (1992), Ford et al. (1994), Ford and Ellis (1999), Matkin et al. (1999b). Acoustic clan designations for British Columbian residents from Ford et al. (1994). Offshore killer whales identified by G.M.E. based on unpublished data. Tissue samples from identified carcasses were provided by D. Bain (two offshore samples) and D. Nagorsen (L1 pod sample). Icelandic, French and Brazilian samples provided by C. Wright, A. Collet, and E. Secchi respectively. <sup>1</sup>Sampling location is given in square brackets when subpopulation is unknown.

(*Grampus griseus*) haplotype (Genbank accession number AB018584, contributed by D. Yamagiwa). separate transient and non-transient monophyletic clades of killer whales rooted by the dolphin sequence were supported by 64 and 56 percent of bootstraps respectively, and 96 percent of the bootstrap trees were monophyletic for at least one of the two killer whale groups (Figure 3.2).

#### Microsatellite DNA

Five of the 27 primer sets test failed to amplify microsatellite DNA, and four amplified but were monomorphic. Seven amplified fewer than three alleles in the test data set or produced ambiguous bands, leaving 11 readily-scoreable polymorphic loci (Table 3.3). I amplified all 269 DNA samples from Pacific killer whales at these 11 loci. DNA from 261 dart biopsies was relatively unshredded, and the proportion of missing scores across all loci was 0.004. DNA from eight carcasses was more degraded, and the proportion of missing scores in these samples was 0.174. None of the 11 loci was sex-linked, as heterozygous individuals of both sexes were scored.

The number of alleles per microsatellite locus in the resident, transient, and offshore populations ranged between 3 and 20, with a mean of 7.8. Tests for heterozygote deficiency in the largest putative subpopulation sampled, the northern residents, were negative for all 11 loci, with  $p$  values ranging between 0.27 and 0.91. The size and distributions of the alleles at each locus are presented in Appendix 2, and the gene diversities in Table 3.3. Gene diversity ( $H_e$ ) was significantly greater in transients than residents ( $F_{1,50} = 12.66, p = 0.0008$ ). Gene diversity in the small sample of the offshores was similar to the residents but was not compared statistically.

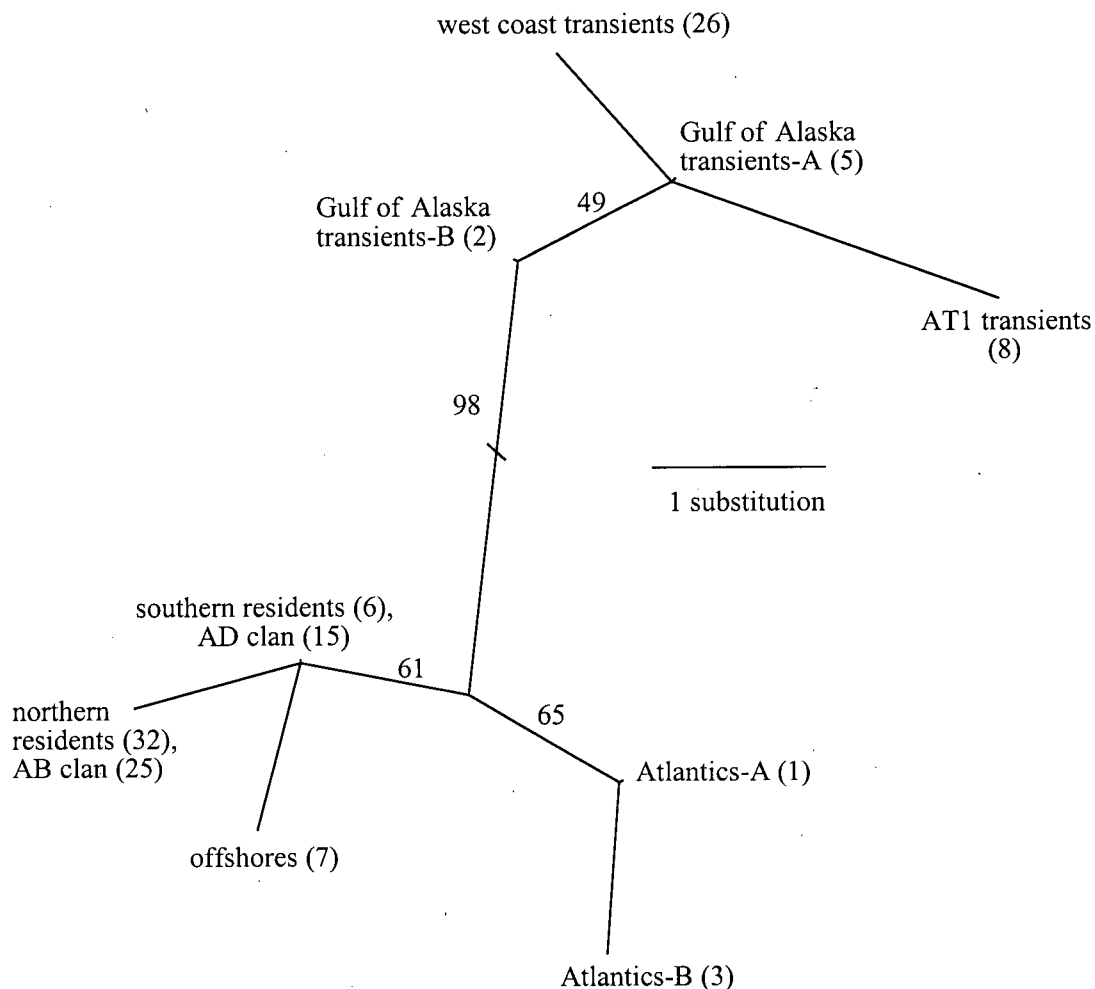

Figure 3.1. Maximum likelihood phylogram based on seven Pacific and two Atlantic killer whale mitochondrial D-loop haplotypes. The numbers on branches indicate percentage bootstrap support (see methods). The number of whales sequenced with each haplotype is shown in brackets. AB and AD refer to two acoustic clans of southern Alaskan residents (see Table 2). The suffixes A and B indicate two different haplotypes from the same subpopulation or, in the case of the Atlantics, the same ocean. The length of the longest branch was reduced by half in this drawing (slash mark). In calculating the tree, a single insertion/deletion in the alignment of the nine groups was accorded the same probability as a T/C transition, however its exclusion from the data did not affect the tree topology.



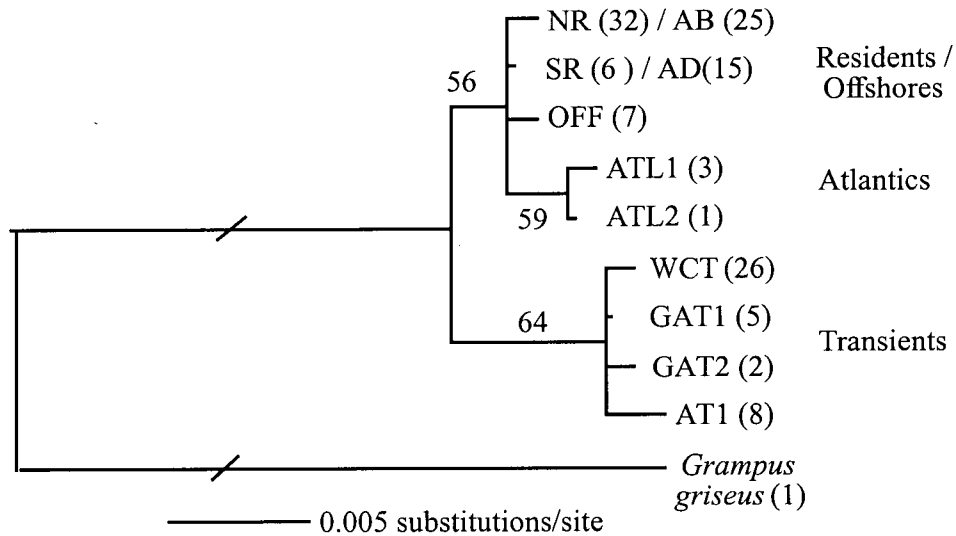

Figure 3.2. Maximum likelihood tree based on mitochondrial D-loop sequences for seven Pacific and two Atlantic killer whale haplotypes. Risso's dolphin (*Grampus griseus*) is included as an outgroup. Numbers on branches indicate percentage bootstrap support. The number of whales sequenced in each category is shown in brackets. AB and AD refer to two clans of southern Alaskan residents (see Table 2). Abbreviations as in Table 1, except ATL1 (2 killer whales captured near Iceland and one that stranded on the west coast of France), ATL2 ( a stranded killer whale from the Brazilian coast), GAT1 (6 of the 8 sequenced GAT whales), and GAT2 (the remaining GAT whales sequenced). In calculating the tree, the single insertion/deletion was accorded the same probability as a T/C transition, however its exclusion from the data did not affect the tree topology. The length of the longest branch was reduced by half in this drawing (indicated by slashes).

Table 3.3. Gene diversities and total number of alleles at 11 microsatellite loci in seven subpopulations of killer whales from Alaska and British Columbia.

Subpop. <sup>2</sup>	FCB4	EV37	FCB12	417	KW2M	FCB17	FCB5	EV1	464	FCB11	415	Mean
SR	0.473	0.384	0.648	0.000	0.627	0.142	0.560	0.362	0.142	0.473	0.560	0.398
NR	0.718	0.550	0.421	0.277	0.399	0.229	0.499	0.432	0.443	0.510	0.612	0.463
SAR	0.545	0.692	0.337	0.234	0.533	0.486	0.494	0.371	0.501	0.577	0.631	0.491
OFF	0.704	0.670	0.264	0.142	0.473	0.264	0.528	0.660	0.264	0.637	0.660	0.479
WCT	0.792	0.733	0.419	0.437	0.815	0.577	0.736	0.711	0.664	0.683	0.742	0.664
GAT	0.879	0.705	0.663	0.358	0.810	0.489	0.758	0.800	0.753	0.780	0.716	0.701
AT1	0.686	0.543	0.699	0.568	0.000	0.503	0.503	0.000	0.523	0.607	0.000	0.421
Alleles <sup>1</sup>	20	9	6	3	8	4	6	7	6	8	9	7.8
Ref. <sup>3</sup>	Buch.	Val.	Buch.	Schl.	Hoel.	Buch.	Buch.	Val.	Schl.	Buch.	Schl.	

<sup>1</sup>Total number of alleles in all seven subpopulations. <sup>2</sup>Subpopulation abbreviations as in Table 3.1. <sup>3</sup>The original reference describing each locus, abbreviated as follows: Buch.: (Buchanan et al. 1996); Val.: (Valsecchi and Amos 1996); Hoel.: (Hoelzel et al. 1998); Schl.: (Schlötterer et al. 1991).

Table 3.4. Weir and Cockerham (1984) estimators of *F*-statistics combined over 11 microsatellite loci for killer whale subpopulations from Prince William Sound, Alaska and British Columbia†.

	<i>F<sub>is</sub></i>	<i>F<sub>st</sub></i>	<i>F<sub>it</sub></i>
all subpopulations [7]	-0.014 (-0.049 — 0.022)	0.205 (0.140 — 0.269)	0.194 (0.114 — 0.276)
resident subpopulations [3]	-0.019 (-0.056 — 0.020)	0.088 (0.032 — 0.146)	0.070 (0.003 — 0.127)
transient subpopulations [3]	0.004 (-0.096 — 0.086)	0.167 (0.088 — 0.241)	0.170 (0.073 — 0.236)

† Subpopulations as listed in Table 3.1. Round brackets indicate ninety-nine percent confidence intervals for each estimator; square brackets the numbers of subpopulations in each analysis.

Estimates of Wright's  $F$ -statistics for all seven putative subpopulations, for the three resident subpopulations, and for the three transient subpopulations are presented in Table 3.4. Population subdivision, or more frequent breeding within subpopulations than expected by chance, is indicated by  $F_{st} > 0$ .  $F_{is}$  and  $F_{it}$  can range from  $-1$  to  $1$ , indicating maximal inbreeding and outbreeding, respectively. Here, the  $F_{st}$  estimates reveal strong segregation between offshores, residents, and transients and weaker subdivision within the resident and transient assemblages. The  $F_{is}$  estimates provide no evidence that inbreeding occurs within the subpopulations. Pairwise  $F_{st}$  estimates are presented in Table 3.5. Figure 3.3 is a neighbour-joining phylogram of the seven subpopulations based on their genetic distances.

Table 3.5. Weir and Cockerham (1984) estimators of  $F_{st}$  combined over 11 microsatellite loci for each pair of sampled subpopulations of killer whale from Prince William Sound and British Columbia. The probabilities that the statistics were not greater than zero, based on permutation tests, were less than 0.001 in every case.

Residents	NR	0.144						
	SAR	0.187	0.076					
Offshores	OFF	0.321	0.278	0.305				
	WCT	0.229	0.278	0.259	0.153			
Transients	GAT	0.226	0.251	0.234	0.182	0.065		
	AT1	0.429	0.430	0.399	0.422	0.224	0.290	
		<u>SR</u>	<u>NR</u>	<u>SAR</u>	<u>OFF</u>	<u>WCT</u>	<u>GAT</u>	
		Residents			Offshores	Transients		

Abbreviations as in Table 3.1. For testing for  $F_{st}$  differences from zero, multi-locus genotypes were permuted among subpopulations 10,000 times.

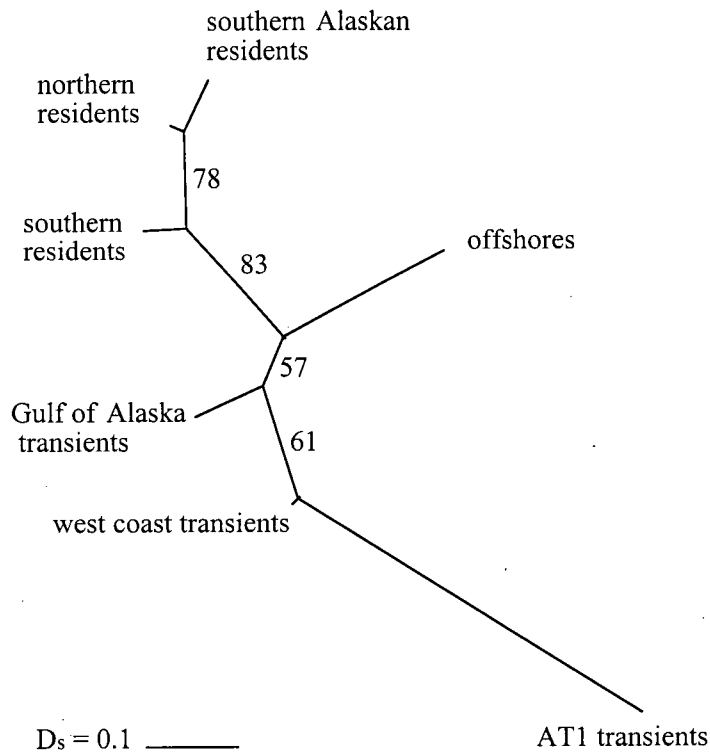

Figure 3.3. Unrooted neighbour-joining phylogram for Alaskan and British Columbian killer whales based on 11 microsatellite loci, using Nei's standard genetic distances. The numbers give percentage bootstrap support. When the offshore population was removed, support for the resident/transient separation was 97%. Atlantic killer whales were not included in this analysis because of their small sample size.

### Discussion

This study builds on the findings of earlier genetic analyses of killer whales in the northeastern Pacific (Stevens et al. 1989, Hoelzel 1991, Hoelzel et al. 1998) but differs from them in the following ways: the number of samples analysed was several times greater than in any earlier study; all Pacific killer whales included in the study were positively identified; four of the six subpopulations analysed here had not been compared previously; at least one whale was biopsied from as many matrilineages as possible (previous studies used multiple

samples from a small set of matriline); and the length of mitochondrial DNA sequenced and the number of microsatellite loci typed were substantially greater than in earlier studies. My findings have five significant implications (expanded on below) that are either novel or more conclusive than in earlier studies.

*1. Resident and transient killer whales are reproductively isolated.*

Individuals classified *a priori* as resident and transient had no mitochondrial haplotypes in common, and there were many more fixed mitochondrial differences between the two populations than among their subpopulations (Figure 3.1; cf. similar findings in Hoelzel et al. 1998). Since the classifications were made independently of any genetic comparisons and my samples were large, I am confident that female migration between the two forms has been extremely rare for many generations. Comparisons of mitochondrial and nuclear microsatellite DNA—inherited from mothers only and from both parents, respectively—are often used to test for sex-biased dispersal. In this case, however, the general patterns are similar: the microsatellite phylogram (Figure 3.3) preserves the separation of residents and transients, pairwise  $F_{st}$  values (Table 3.4) are much higher between resident and transient subpopulations than between subpopulations of a common population, and several loci have population-specific alleles (Appendix 1). These results suggest that neither sex disperses at an appreciable rate between populations.

There is no reason to suppose that residents and transients are reproductively incompatible (that is, separated by post-mating isolating mechanisms). Both have crossed with Icelandic whales in captivity (whale identities from Hoyt 1984, mating records from Duffield et al. 1995) and produced fertile offspring. Since residents and transients are sympatric, their genetic separation must be maintained by positive assortative mating. Mating preferences could be based on culturally or genetically inherited behaviours that distinguish residents and transients, such as those associated with foraging (e.g. Morton 1990, Barrett-Lennard 1996a, Ford et al. 1998) or communication (Ford 1991). They could also be influenced by subtle differences in phenotype (see Bigg et al. 1987, Baird and Stacey 1988). However, it seems unlikely that individual mating preferences alone could account for the near complete genetic isolation of the two populations. I argue in the final part of this paper that the social

cohesion of subpopulations is likely the most important factor in the isolation of residents and transients.

*2. The resident and transient populations are divided into genetically differentiated regional subpopulations.*

The finding of fixed mitochondrial differences between the northern and southern residents effectively rules out substantial female-mediated gene flow between them (Figure 3.2). The microsatellite analysis (Tables 3.4 and 3.5, Figure 3.3) showed that they are also strongly differentiated at nuclear loci, indicating that male-mediated gene flow is also small at best. Although the two subpopulations are usually spatially separated in summer, little is known about their travel patterns in winter. Two of the southern resident pods have been sighted several times in spring travelling towards their summer feeding grounds through Johnstone Strait, a core area for northern residents. There have also been rare sightings of northern residents in areas normally frequented by southern residents. Members of the two populations must come into acoustic and perhaps visual contact at least occasionally, indicating that their reproductive isolation results from behavioural or social factors rather than physical separation.

The southern Alaska residents have two mitochondrial DNA haplotypes, one in common with the southern and the other with the northern residents, suggesting that they share relatively recent maternal ancestors with both groups. Their microsatellite genotypes indicate relatively weak separation from the northern residents and much stronger separation from the southern residents, as reflected in the  $F_{st}$  values in Table 3.5 and the bootstrap values in Figure 3.3. These patterns may reflect contemporary patterns of gene flow, with occasional matings taking place between the southern Alaskan and northern residents but few matings between either population and the southern residents, or they may reflect historical associations and founding events. The only observation of possible association between resident subpopulations was a sighting of two pods of southern Alaska residents in close proximity to two northern resident pods (Dahlheim et al. 1997). In contrast, pods from the same subpopulation associate and intermingle frequently.

The general pattern of genetic differentiation among transient subpopulations is similar to that of residents. The west coast transients and AT1's each have a single unique mitochondrial haplotype; two unique haplotypes were found in the Gulf of Alaska transients. The four transient haplotypes cluster more closely with each other than with the haplotypes of any other population with strong bootstrap support (Figure 3.1). At the same time, the fixed sequence differences between transient subpopulations suggest that female dispersal between them is rare at best. However, my sample of Gulf of Alaska transients is small, and it is possible that AT1 or west coast haplotypes will be discovered in the Gulf of Alaska transients with more sampling effort. The microsatellite-based pairwise  $F_{st}$  estimate for the west coast and Gulf of Alaska transient subpopulations is relatively low, evidence that their separation is either incomplete or has occurred recently. The separation of both groups from the small AT1 transient subpopulation appears to be older and/or more complete. The isolation of the AT1's appears likely to result in its extinction, as it presently has fewer than 15 members and has not produced surviving offspring for 16 years (Matkin et al. 1999b).

The subdivision of both residents and transients into genetically differentiated parapatric subpopulations cannot be explained by mating preferences associated with divergent behaviours or phenotypes, and suggests that subpopulations are cohesive social units, not simply collections of individuals sharing a common range. Cohesion requires that individuals reliably distinguish members of their social unit from non-members. In killer whales recognition is likely based on direct encounters between individuals and on acoustic contact. Killer whales move up to 160 km per day and are capable of communicating acoustically over distances of at least 10 km (unpublished data); it is therefore likely that every member of the subpopulation encounters every other member frequently.

### *3. Fish-eating and mammal-eating killer whale traditions in the northeastern Pacific diverged once.*

The terms resident and transient were first applied to killer whales in British Columbia (Bigg et al. 1982). The same terms were later used to classify killer whales in the Prince William Sound/ Kenai Fjords region of Alaska because of obvious behavioural and ecological parallels (Leatherwood et al. 1990). Since neither resident nor transient killer whales have

been known to move between the two areas, it was not known whether the divergence into mammal-hunting and fish-hunting specialist groups had occurred once or multiple times. I divided the biopsy sampling between the two areas in order to address this question. Both the nuclear and the mitochondrial DNA analyses presented here are consistent with reciprocal monophyly, meaning that each of the resident subpopulations is more closely related to the other resident subpopulations than to any of the transient subpopulations, and vice versa. This pattern implies that the separation of the resident and transient populations stems from a single divergence, and provides no evidence that social segregation between fish-eating and mammal-eating groups of killer whales occurred independently in different locations. The initial divergence could have occurred sympatrically or allopatrically, but the reproductive isolation of the two populations suggests that the divergence is now widening in sympatry.

The best evidence of feeding specialization in killer whales from regions other than the northeastern Pacific comes from Berzin and Vladimirov (1983), who described morphologically-distinct fish-hunting and mammal-hunting killer whales in Antarctic waters. In contrast, photo-identified killer whales that have been observed feeding on elephant seals have also been seen feeding on fish in the Crozet Archipelago (Southern Indian Ocean, 46°S, 52°E; Guinet 1990, 1992). Thirteen killer whales biopsied in the Crozet Archipelago had very similar mitochondrial D-loop sequences to the resident clade (LBL, unpublished data). No killer whales with D-loop sequences similar to those of transients have been identified outside the coastal waters of the northeastern Pacific.

#### *4. Offshores are genetically differentiated from all known resident and transient subpopulations.*

Residents and offshore killer whales probably share more recent maternal ancestors with each other than either does with transients, based on their similar mitochondrial haplotypes and on evidence provided by rooted and unrooted mitochondrial trees (Figures 3.1 and 3.2). In contrast, microsatellite loci group offshores and transients (Figure 3.3). This situation is consistent with three possible scenarios of historical and contemporary gene flow: (1) offshores diverged from ancestral residents but have occasionally mated with non-offshore males, usually transients, (2) offshores diverged from ancestral transients and experienced



mitochondrial DNA introgression after one or more resident females emigrated into and mated within the group, or (3) the offshore divergence preceded that of residents and transients and was followed by occasional hybridization with both populations. In view of the extremely strong propensity of contemporary resident females to stay in their matriline for life (Bigg et al. 1990, this study) and their tendency to mate within their subpopulation (Chapter 4), the first scenario is most likely. However, the sample size of offshores was small, and the picture of the relative relatedness of residents, transients and offshores may change as more samples are acquired.

*5. Residents remain within their natal pods for life and have lower levels of genetic variation than transients.*

One of the most striking findings to emerge from nearly 30 years of field studies of resident killer whales is the absence of dispersal of members of either sex from their natal matriline (Ford et al. 2000). Here I asked whether the lack of dispersal over this period is typical of the recent history of the population. The southern Alaska resident group consists of pods belonging to two acoustic clans, each of which is fixed for a different mtDNA haplotype. Pods associate independently of clan membership, so individuals are in frequent social contact with members of other clans. There is little nuclear DNA differentiation of the two clans, and paternity analysis indicates that inter-clan matings are common (Chapter 4). If females dispersed between pods even rarely, the observed relationship between clan membership and mitochondrial haplotype would break down. I conclude therefore that successful dispersal by female residents has not occurred for many generations.

Mitochondrial comparisons cannot detect historical trends in male dispersal, but can identify males that have themselves dispersed between subpopulations. I found no cases of males carrying a mitochondrial haplotype different from that of the rest of their pod among the southern Alaskan residents and conclude therefore that male dispersal is presently rare.

Whitehead (1998) noted that low mtDNA diversity typifies cetaceans that live in social groups with little or no female dispersal and proposed that mtDNA hitchhikes on vertically-transmitted cultural innovations that increase the relative fitness of group members. Amos (1999) offered an alternative explanation: the effective population size of mitochondria is a

function of the number of matriline, not of the census size, in strictly matrilineal species. I found higher levels of mitochondrial DNA variation in transients than in residents (four haplotypes in three subpopulations and two haplotypes in three subpopulations, respectively). This finding is consistent with both hypotheses since both link mtDNA variability to dispersal, and transients, unlike residents, disperse between pods (Ford and Ellis 1999).

Microsatellite DNA diversity was also significantly higher in transients than in residents. This difference may indicate that the mean subpopulation size of transients is larger than that of residents. Although more residents than transients have been photo-identified and catalogued, transients are more difficult to census than residents (Ford and Ellis 1999), and many west coast and Gulf of Alaska transients may remain uncatalogued. Transient subpopulations may also be less closed to gene flow than residents, and their genetic diversity may be augmented by occasional matings with either offshores or unknown subpopulations of killer whales. Finally, the patterns could result from historical contingencies—recent bottlenecks or founder effects—in residents. I rule out a fourth explanation in Chapter 4, that matings between close kin are frequent in residents since they do not disperse from their natal groups.

#### Sympatric origin of population subdivision

I have shown that killer whales in the northeastern Pacific show a remarkable amount of population structure in the absence of physical boundaries. Not only is there complete or nearly complete segregation of sympatric feeding specialist populations, but each population is strongly subdivided. This structure appears to be maintained by a strong behavioural tendency for individuals to avoid associating with killer whales outside their subpopulation. Since subpopulations are relatively small (average resident effective subpopulation size is approximately 70, assuming that all females of reproductive age and 1/3 of mature males breed), periodic inter-group mating should help to maintain variation and to restore beneficial alleles lost to mutation and drift. Presumably, associating with non-group members has historically had attendant costs that outweighed these advantages. While the nature and extent of these costs is conjectural, they plausibly include risks of aggressive

conflict, resource competition during the period of association, future competition arising from the transfer of local knowledge, disease transmission, and similar factors. These costs, however, likely apply to many other social species that do not show sharp sympatric and parapatric population subdivision and are thus not wholly satisfying in explaining the patterns seen in killer whales.

I suggest that the ability of killer whales to maintain long-term traditions, particularly vocal traditions (Ford 1991), reduces disadvantages and increases advantages to individuals of remaining within their subpopulation. Killer whales advertise their presence using culturally-inherited dialects (Ford 1991). This makes reliable recognition possible, as discussed above, allowing both kin-selected and reciprocally altruistic behaviours to develop (Trivers 1971). These behaviours should reduce the likelihood of interference competition or other conflict, and could also foster co-operative resource defence. I show in Chapter 4 that dialect similarity and probability of mating are negatively correlated within resident subpopulations, suggesting that vocal traditions allow individuals to avoid inbreeding while remaining in their subpopulations. Culturally inherited vocal traditions are unusual in mammals, which may explain why they rarely exhibit the strong social cohesion and propensity to avoid non-group members that characterize killer whale subpopulations.

I propose that the creation of new killer whale subpopulations results from the fission of large subpopulations in the following manner. (1) When a subpopulation expands its range beyond a critical size, member pods that usually forage at different extremes of the range encounter each other less and less often, and eventually cease to recognize each other as members of the same subpopulation. (2) A range boundary forms between the groups of pods as their social separation becomes complete. (3) Pods that usually forage in the central part of the ancestral range initially associate with both of the groups but are eventually drawn into one of them, completing the isolation of the new subpopulations. A similar process of clan formation has been described in the Mae Enga people of New Guinea (Meggitt 1965). The initial divergence of residents and transients could have occurred in a similar manner, prior to development of feeding specializations. The formation of new groups in this way is expected to result in greater levels of genetic variance among groups than would be the case

if new groups formed from migrants drawn from the population at large (Whitlock and McCauley 1990), which may explain the high *Fst* values in Table 3.5 relative to those reported in other social mammals (summarized in Storz, 1999).

There has been much interest in the role in speciation of learned dialects in birds (e.g. Baptista and Trail 1992, Grant and Grant 1996), but little consideration of the possibility of speciation arising from culturally-transmitted traditions in mammals (although Boyd and Richerson 1987 suggest that cultural transmission can lead to population subdivision in humans). Killer whales appear to be good candidates for such consideration. Resident and transient killer whales occupy separate ecological niches, and do not interbreed, even in sympatry. They are separate species now, by Simpson's (1961) evolutionary definition, and barring demographic or environmental catastrophes, there is no obvious impediment to them becoming biological species *sensu* Mayr (1942) over time.

## CHAPTER FOUR

### Mating Systems in Resident Killer Whales: Outbreeding Without Dispersal

#### Introduction

Given the choice, members of social species would remain in their natal groups for life. The benefits of staying are many and include kin-selected behaviours such as cooperative foraging, shared vigilance against predators, group defence of resources, pooled care of young and the exchange of information. Despite these advantages, at least one sex disperses in almost all species—generally males in mammals and females in birds (Greenwood 1980). Dispersal is thought to be driven by inbreeding avoidance and/or intra-group competition for mates or resources (Johnson and Gaines 1990), and the manner in which it occurs significantly affects the way that genetic variance is partitioned in a population (Chesser 1991). Here, I present a genetic analysis of mating patterns and social structure in a population of killer whales (*Orcinus orca*) in which no dispersal has been recorded. Members of the population are referred to as *residents*, and have been the subject of much research since the early 1970's. They are distributed along the coasts of Washington State, British Columbia, and southern Alaska and feed on fish, particularly salmon, *Onchorhynchus* spp. (Ford et al. 1998).

The resident killer whale population is sympatric with a population of marine mammal-eating killer whales referred to as *transients*, from which they are socially and genetically isolated (Bigg et al. 1990, Chapter 3). They are also parapatric with a third, poorly-studied population referred to as *offshores*. Residents are unusual among social mammals in that neither sex disperses from its mother's group. The only other mammal that is believed to be similar in this respect is the closely-related long-finned pilot whale, *Globicephala melas* (Amos et al. 1993). The fundamental social unit of resident killer whales is the *matriline*, comprising a female and her descendants— typically 4-12 individuals from 2-4 generations. The members of a matriline usually swim together and are rarely separated by more than a few kilometres. Groups of matrilines that associate frequently are believed to share recent maternal ancestors (Bigg et al. 1990) and are referred to as *pods*. Each resident pod uses a

distinctive set of stereotyped calls, or dialect; pods with related dialects are considered to belong to the same *acoustic clan* (Ford 1991). A *subpopulation* is a group of acoustic clans that share a common range. Bigg et al. (1990) referred to this level of social organization as a *community*, to emphasise that all of its member pods associate, at least occasionally. Each subpopulation contains one or more acoustic clans. Pods associate frequently within and between clans in their subpopulation but rarely if ever associate with pods from other subpopulations (Bigg et al. 1990).

At least three subpopulations of resident killer whales live along the Pacific coast of North America. The *southern* residents have a single clan and inhabit the waters off northern Washington and southern British Columbia, the *northern* residents have three clans and extend from southern British Columbia to the southern tip of Alaska, and the *southern Alaskan* residents have two clans and range northwest from the southern tip of Alaska at least as far as Kodiak Island (Figure 1.1). The nested structure of the matriline, pods, and clans of the three subpopulations is depicted in Figure 4.1. All members of the southern and northern subpopulations and most of the southern Alaskan residents have been individually photo-identified based on distinctive natural markings and fin shape, and their maternal relationships and association patterns have been investigated in detailed observational studies (see Ford et al. 2000). This study encompassed all three subpopulations but focused on the northern residents, which are more complex in pod and clan structure than the southern residents and have been studied more extensively than the southern Alaskan residents.

Mating and overt courtship behaviours are rarely seen in killer whales, and mating systems have not been described. My principle objective was to analyse mating patterns in residents based on the analysis of DNA samples from identified individuals. I also sought to determine the accuracy of observational studies in identifying maternal relationships in resident killer whales and to examine the relationships between acoustic repertoires and genetic relatedness. The molecular analysis focused on polymorphic microsatellite regions of the nuclear genome. The microsatellite data were used both for parentage testing and to calculate fixation indices.

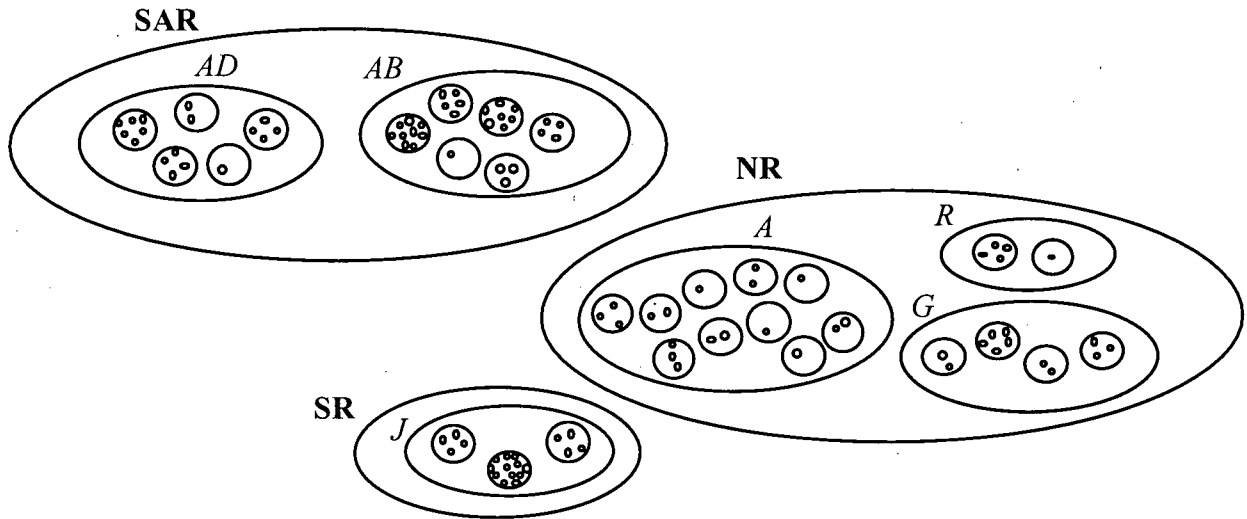

Figure 4.1 Hierarchical population structure in resident killer whales. The outer ellipses depict subpopulations, the inner ellipses clans, the larger circles pods, and the smaller circles matriline units. NR, SAR, and SR refer to the northern resident, southern Alaskan resident and southern resident subpopulations, respectively. Clan names are based on Ford et al. (2000) and Yurk et al. (in prep) and are italicized. The number of matriline units shown in each pod is based on Ford et al. (2000) and Matkin et al. (1999b).

## Methods

### Biopsy sampling

The majority of samples were collected on the central British Columbian coast from (50°45'-53°0'N, 127°0'-129°45'W). Samples were also collected in the Prince William Sound and Kenai Fjords area of southern Alaska (59°30'-61°0'N, 146°15'-151°0'W). When resident killer whales were located, all were visually identified and photographed and then lightweight darts were used to take skin biopsies from selected individuals. First priority was given to mature males, followed by juveniles, and finally mothers of sampled juveniles. Individuals that were not highly distinctive in appearance were re-photographed as they were biopsied, and their identity was later checked using identification catalogues (Ford et al. 1994, 2000; Matkin et al. 1999b). Details of the field procedures, biopsy method, sample preservation, and DNA extraction are described in Chapters 2 and 3. Biopsy samples were

collected from 216 identified resident killer whales, including 8, 126 and 82 individuals from the southern, northern, and southern Alaskan subpopulations respectively. In addition, 46 biopsies were taken from transients and 7 from offshores. The identities of the biopsied whales are given in Table 3.2.

#### Microsatellite analysis.

Genotypes of all biopsied whales were determined at 11 microsatellite loci: EV1, EV37 (Valsecchi and Amos 1996); FCB4, FCB5, FCB11, FCB12, FCB17 (Buchanan et al. 1996); 415, 417, 464 (Schlötterer et al. 1991); and KW2M (Hoelzel et al. 1998). Polymerase chain reaction products of each locus were labelled with P<sup>33</sup>, the products were electrophoresed on denaturing acrylamide-based gels, and the gels were exposed to photographic film (details in Chapter 3). Alleles were sized by comparing them to a reference DNA sequence run on each gel. The entire procedure was repeated for any DNA samples that did not produce clear bands of unambiguous size. All films were scored twice as an error check, and the entire analysis was repeated at each locus for 5% of the samples as a second error check.

#### Parental Exclusions

Bigg et al. (1987, 1990) and subsequent authors inferred maternal relationships based on repeated sightings of identified whales in close association. Most inferences were based on calf/adult female associations, but some were based on associations between adults. To test the validity of these inferences, I checked the microsatellite genotypes for matches between each juvenile and its putative mother. Matches were considered to have failed if a cow and juvenile did not have at least one allele in common at each of the 11 loci. I then searched for matches between juveniles whose putative mothers were not excluded in the first test, and all males that were of reproductive age when the calf was conceived. As male killer whales reach sexual maturity between 10.5 and 15.5 years (Olesiuk et al. 1990) and gestation lasts approximately 17 months (Walker et al. 1988), I considered males to be candidate fathers if they were born 12 or more years before the calf and were not known to have died more than two years prior to the calf's birth. Paternity candidates were considered to be possible fathers if they possessed each of a calf's alleles that could not be attributed to its mother.



To test whether mate choice in resident killer whales is contingent on pod, clan, and/or subpopulation membership, I compared group memberships of offspring and their matching candidate fathers. The method is conceptually similar to an  $F$ -statistic based test, but differs in that it reveals contemporary rather than historical patterns. Offspring that matched more than one candidate father were excluded from the tests unless all of the matching candidates came from the same group as each other. Log-likelihood ratio contingency tests (Zar 1996) were used at the subpopulation and clan levels to determine whether the ratio of genotype matches within groups to matches between groups was independent of the ratio of genotype mismatches within groups to mismatches between groups. A different approach was needed at the pod level, as random mating would result in relatively few intra-pod paternities. Since pods by definition swim together at least half the time, I assumed that half of the calves would result from intra-pod matings if mate choice was independent of pod membership. I used a binomial test (Zar 1996) to estimate the probability of the observed numbers of intra-pod and extra-pod paternal matches under this assumption.

An alternative approach to the strict exclusion method of parentage testing used here involves estimating the likelihood of parentage based on genotype similarities (e.g. Marshall et al. 1998, Goodnight and Queller 1999). This has the advantage of identifying which of two or more non-excluded father candidates is more likely to be the true father of an offspring, and reduces the probability of incorrectly excluding true fathers because of genotyping errors or mutation. While useful in many applications, higher-than-average likelihood-of-parentage values are necessarily assigned to close relatives of offspring because of genetic correlations resulting from common descent, which makes the method problematic for distinguishing between closely related and unrelated candidate parents. I therefore did not use it here and instead used genotyping checks to minimize false exclusions and focused on offspring with single candidate fathers or sets of fathers from a common group.

#### $F$ -statistic analysis

Wright's (1951) fixation indices  $F_{is}$ ,  $F_{st}$  and  $F_{it}$  were used to analyze the partitioning of genetic variation. The fixation indices are measures of standardized variances in allele

frequencies that detect departure from Hardy-Weinberg equilibrium caused by biased inbreeding, biased outbreeding, or population subdivision and drift. The subscripts *i*, *s* and *t* refer to individual, subpopulation and total population, thus  $F_{is}$  detects inbreeding in individuals relative to their subpopulation,  $F_{st}$  detects inbreeding in subpopulations relative to the total population (providing a measure of population subdivision), and  $F_{it}$  detects inbreeding relative to the total population.  $F_{st}$  values range from 0 in panmictic populations to 1 in populations made up of subpopulations that are fixed for different alleles. In contrast,  $F_{is}$  and  $F_{it}$  can range between -1 and 1, indicating maximal outbreeding and inbreeding respectively. Sugg et al. (1996) provide a useful review of the interpretation of  $F$ -statistics in socially structured populations. Calculations were performed according to the formulae of Weir and Cockerham (1984), as implemented in the program FSTAT 1.2 (Goudet 1995). Confidence intervals were determined by bootstrapping 1000 times, using the 11 microsatellite loci as resampling units.

#### Genetic distance and acoustic similarity correlation analysis

A matrix permutation procedure (Mantel 1967) was used to test whether the genetic distance between pods is correlated with the similarity of their acoustic repertoires. The genetic measure used was coancestry distance  $d$  (Weir 1996, p. 194) based on the 11 microsatellite loci described above. The measurements of acoustic repertoire similarity used were from Ford (1984) and take the form of an index varying from 1 when pods have identical repertoires to 0 when pods have no calls in common. The analysis was based on pairwise comparisons of all of the pods with five or more DNA-sampled members in *A-clan*, the most thoroughly-sampled acoustic clan. The correlation coefficient calculated between corresponding elements of the genetic distance and acoustic similarity matrices was compared to the distribution of correlation coefficients obtained in a similar manner after each of 1000 random permutations of the matrix rows and columns. The probability of the observed correlation under the null hypothesis was equivalent to its ranking in the distribution.

## Results

### Maternal and Paternal Assignments

I tested 69 pairs of northern resident killer whales that were identified as mother/offspring pairs based on observed associations between mature females and calves or juveniles by Bigg et al. (1990), and/or Ford et al. (2000). The genotypes were consistent with a maternal relationship in every case. By comparing the genotype of each of the 69 calves to all northern resident females that were of reproductive age when it was born, I determined that the genetic test had a 74% chance of excluding any incorrect northern resident candidate mother, and a 64% chance of excluding an incorrect candidate mother from its own pod. I then estimated an upper limit for the fraction ( $x$ ) of the putative mothers that were confirmed by the genetic tests but in fact were not the mother of the calf in question by determining the maximum value of  $x$  that gives at least a 5% chance of finding 0 mismatches in 69 comparisons. Assuming that the true mother will never be excluded and that all false matches occur within pods, I have  $(1 - 0.64)^{69x} = 0.05$ , or  $x = 0.042$ . Thus, an upper limit for the expected number of errors in the 69 matches is three. In addition to the maternal assignments just described, I tested four pairs of whales postulated by Bigg et al. (1990) to be mothers and offspring based on social bonds between individuals that were mature when first seen. Two of these pairs failed to match genetically.

I tested for candidate fathers that matched the paternal genotype of the 69 individuals referred to above among all of the sampled northern resident males that were mature when they were born. Approximately 85% of the mature male northern residents that were alive at the beginning of the study were sampled, but many of the offspring were more than 15 years old then, thus many fathers may have died before the study. A total of 2110 tests were made. All candidate fathers were excluded for 45% of the calves, and one or more matches were made for the remaining 55%. Assuming that the number of correct matches was between 0 and 55%, the power of the procedure to exclude incorrect fathers (equal to the total number of exclusions over the number of non-father males) was between 94.3 and 96.2 percent.

## Paternity matches within and between clans, pods and subpopulations

### *Subpopulations*

A total of 105 resident offspring belonging to 3 subpopulations were screened for possible fathers against all sampled resident males. Twenty one of them matched a single father and an additional 18 matched a set of males that were all from the same subpopulation. Of the 39 matches, 33 (85%) were with candidate fathers from the same subpopulation as the offspring. All of the matches between subpopulations were between the northern residents and southern Alaskan residents (but few southern residents were sampled). The hypothesis that mating is independent of subpopulation membership was rejected (log-likelihood ratio test,  $p < 0.0001$ ). No matches were found when the same set of resident offspring was screened for possible matches with transient and offshore males.

### *Clans*

Because the analysis above indicated that most matings occur within, not between subpopulations, mating patterns with respect to clan membership were analysed separately for northern residents and southern Alaskan residents. The southern resident subpopulation was not included in this analysis because it contains only a single clan. In the northern residents, 17 offspring matched a single candidate father and six matched a set of males that were all from the same clan. Of these 23 offspring, 5 matched males from their own clan and 18 matched males from clans other than their own. The proportion of inter-clan matches (0.78) was higher than the proportion of inter-clan paternity tests (0.54), and the hypothesis that mate preferences are independent of clan membership was rejected (log-likelihood ratio test,  $p = 0.014$ ). In the southern Alaskan residents, three offspring had a single matching candidate father and two matched a set of male clan-mates; of these five matches three were within and two between clans, and the hypothesis that mating preferences are independent of clan membership was not rejected (log-likelihood ratio test,  $p = 0.377$ ).

### *Pods*

Seventeen northern resident offspring matched a single father candidate and two matched a set of males from the same pod. Of these 19 matches, all but one were between pods. The binomial probability of obtaining this result if mating is equally frequent within and between

pods is  $<0.0001$ . In the southern Alaskan residents, three individuals matched a single candidate and one matched a set of males that were all from a single pod. All matches were between pods. The probability of obtaining this result if mating was equally likely within and between pods was 0.062. This analysis was not performed on southern residents, because only one mother-calf pair was sampled, and the calf did not match any males. When the analysis was repeated on all three resident subpopulations combined, 24 out of 25 matches were between pods. There were two pairs of siblings that each had a single matching candidate father. In both cases, the siblings matched different males.

#### F-statistics

Partitioning of genetic variance within and between pods was analysed at acoustic clan and subpopulation levels. Two clans among the northern residents were analysed; one (*A*) contains 10 pods and the other (*G*) contains four. The third northern resident clan (*R*) contains only two pods and was not included. The results of this analysis are presented in Table 4.1. *F<sub>is</sub>* values were significantly less than zero in all but one analysis, indicating more heterozygosity than expected if mating were random and consistent with a pattern of biased outbreeding. The exception was the analysis of clans within the southern Alaskan resident subpopulation, in which *F<sub>is</sub>* did not differ significantly from zero. Positive *F<sub>st</sub>* values indicated significant partitioning of genetic variance among pods in A-clan, among pods in the entire northern resident subpopulation, among clans in the northern resident community, and among subpopulations in the entire resident population.

Table 4.2 presents pairwise *F<sub>st</sub>* for all of the acoustic clans within the northern, southern, and southern Alaskan residents. *F<sub>st</sub>* values were lower for pairs of clans from the same subpopulation than for pairs from different subpopulations. Pairs including J-clan, the single southern resident clan, had the highest *F<sub>st</sub>*'s. Interestingly the J-clan / AD-clan pair had the highest *F<sub>st</sub>* estimator, despite the fact that they have the same mitochondrial D-loop haplotype (see Figure 3.1).

### Correlation of acoustics and genetics

Figure 4.2 is a plot of acoustic repertoire similarity vs genetic distance for pods *A1*, *A4*, *A5*, *B1*, *C1*, and *H1*, which all belong to *A*-clan of the northern resident subpopulation (see Ford et al. 2000 for description of *A*-clan and its member pods). Acoustic similarity and genetic distance were negatively correlated ( $r = -0.513$ ,  $p = 0.035$ , Mantel test). One pod (C1) contributed to the two points nearest the origin that deviate from the general trend. These deviations could be a genetic sampling artefact or could indicate that unknown factors occasionally cause the repertoires of closely-related pods to diverge rapidly.

Table 4.1. Overall  $F_{is}$ ,  $F_{st}$ , and  $F_{it}$  estimators for resident killer whale pods, acoustic clans, and subpopulations from the northeastern Pacific Ocean, based on 11 microsatellite loci.

individ- iduals	sub-group	total group	$F_{is}$	$F_{st}$	$F_{it}$
105	pod [10]	A- clan	<u>-0.107</u> (-0.163 — -0.048)	<u>0.066</u> (0.045 — 0.086)	-0.034 (-0.087 — 0.017)
76	pod [4]	G- clan	<u>-0.414</u> [-0.247 — -0.013)	0.025 [-0.008 — 0.065)	-0.113 [-0.220 — 0.007)
214	pod [16]	NR sub- population	<u>-0.112</u> [-0.138 — -0.087)	<u>0.062</u> [0.048 — 0.082)	<u>-0.043</u> [-0.078 — -0.004)
214	clan [3]	NR sub- population	<u>-0.064</u> [-0.095 — -0.031)	<u>0.027</u> [0.012 — 0.043 )	-0.035 [-0.073 — 0.007)
360+	clan [2]	SAR sub- population	0.025 [-0.073 — 0.119)	0.008 [-0.003 — 0.020)	0.033 [-0.069 — 0.126)
656+	subpop.[3]	all residents	-0.019 [-0.056 — 0.020)	<u>0.088</u> [0.032 — 0.146)	<u>0.070</u> [0.003 — 0.127)

A- and G-clans are two acoustic clans of the northern residents. NR and SAR refer to the northern resident and southern Alaskan resident subpopulations, respectively. The *individuals* column lists the approximate number of individuals in each corresponding total group. Square brackets contain the number of subgroups in the corresponding total groups. Numbers in round brackets are 99% confidence intervals, obtained by bootstrapping the loci. Single or double underlining indicates that the entire 99% confidence interval of the fixation index is below or above zero, respectively.

Table 4.2. Pairwise  $F_{st}$  estimators based on 11 microsatellite loci for six acoustic clans of killer whales from the northern resident, southern resident, and southern Alaskan resident subpopulations from British Columbia and Alaska. The estimators were significantly greater than zero ( $p < 0.001$  in every case except AD/AB, for which  $p = 0.035$ ).

Northern	G	0.023				
	R	0.023	0.052			
Southern	J	0.141	0.173	0.175		
Southern Alaskan	AB	0.070	0.072	0.078	0.177	
	AD	0.101	0.099	0.096	0.208	0.008
		A	G	R	J	AB
		Northern			Southern	Southern Alaskan

A, G, R, J, AB, and AD are the names of acoustic clans (see Figure 4.1). Values in boxes are  $F_{st}$  estimators for clans within subpopulations. The arrow indicates the AD/J pair, which are allopatric but have identical mitochondrial D-loop haplotypes.

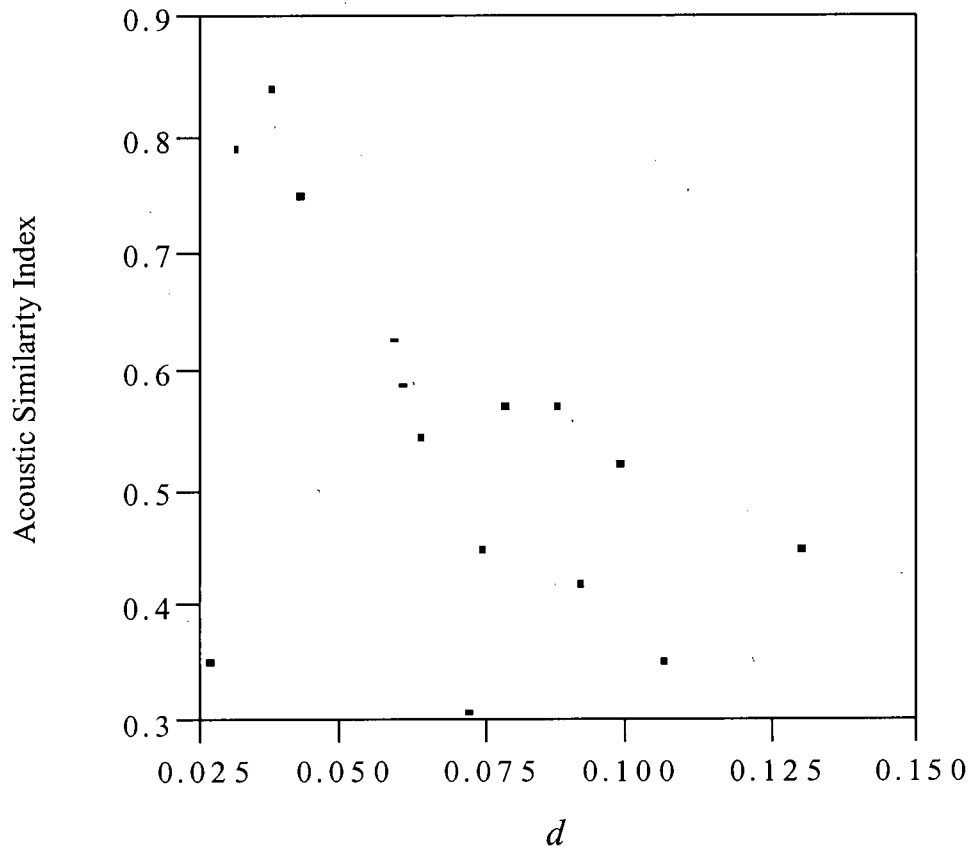

Figure 4.2. Pairwise acoustic similarity index values versus microsatellite-based coancestry distance  $d$  (Weir 1996) for resident killer whale pods belonging to a single acoustic clan.



## Discussion

### *Validity of association-based inferences of maternity*

For observers to study social organization, they need to recognize individuals reliably. Systematic individual recognition of killer whales was pioneered in the early 1970's by Bigg (1982). By the early 1990's, many features of resident killer whale social organization had been described, including the lack of dispersal of individuals from matriline, the existence of acoustic clans, and the social segregation of at least two parapatric subpopulations. Maternal relationships were key to these studies, and were inferred on the basis of close association between mature females and young calves during repeated sightings (Bigg et al. 1990). Because these associations remained strong as calves matured, inferences were also made about the maternity of whales that were juveniles or adults when first sighted. Bigg et al. (1990) classed maternal assignments based on observed associations between adult females and calves as *positive*, and those between adult females and either juveniles or younger adults as *highly probable* and *probable*, respectively. Subsequent authors (Ford et al. 1994, 2000) substituted the terms *probable* and *possible* for Bigg et al.'s final two categories.

The genetic tests presented here proved the efficacy of the Bigg et al. (1990) association-based method of maternal assignment based on female-calf and female-juvenile association patterns. Some errors might have been expected because adult females consistently travel in close association with other adult females and because alloparenting is known to occur (Waite 1988); my results indicate that these factors are unlikely to obscure true maternal relationships when repeated observations are made. The results also indicate that calf adoption is rare in resident killer whales. Maternal assignments based on associations between adults proved less reliable, with two out of four found to be incorrect. Bigg et al. (1990) noted that the bonds between females and their adult offspring are subtle and vary with time, and assigned "probable" maternity only when a close association between adults continued over many years. Despite this measure, the probability of correctly determining the mothers of adults based on association patterns appears to be much lower than it is for

calves and juveniles. The two genetic mismatches between females and close companions suggest that individuals change their affiliation patterns following the death of their mother.

#### *Exogamy without dispersal*

All but one test of within-pod paternity in resident killer whales was rejected in this study. The rarity of intra-pod matings was supported by the  $F$ -statistics. If mating takes place between but not within pods, then pod members should be more heterozygous than if they mated randomly within pods, and a negative  $F_{is}$  is expected. Here,  $F_{is}$  was negative for resident pods within the two clans and one subpopulation tested (Table 4.1). The clustering of maternal relatives in pods is expected to cause pods to be genetically differentiated despite the apparent inter-pod mating system. This differentiation is expected to be reflected in positive  $F_{st}$  values. Statistical support for  $F_{st} > 0$  was strong in two of the three analyses. These results suggest that non-dispersing resident killer whales avoid inbreeding at least as effectively as they would if they dispersed from their natal groups.

To my knowledge, long-finned pilot whales are the only mammals other than resident killer whales in which individuals of both sexes are known to reside within, but mate outside, their natal groups (Amos et al. 1993). Amos et al. suggested that male pilot whales experience inclusive fitness benefits by remaining in their natal groups because they assist their female relatives, perhaps by contributing to group defence or to communal feeding strategies. There is no evidence that the non-dispersal of resident killer whale males is explained by assistance to relatives. Many successful matrilineal groups contain no adult males at all. Adult males become less integral to the group following the death of their mother, and begin to travel behind or on the periphery of their sisters' matrilines (Bigg et al. 1990) or on their own (Ford et al. 2000). If a male benefits the group and stays in it primarily to increase his inclusive fitness, it is not clear why his social role should diminish after the death of his mother. A diminished social role is more readily explained if males are of relatively low value to their group. Half-sib relationships are likely to be more common than full-sib relationships since a) mating apparently takes place during temporary associations (see below) and b) two pairs of possible half sibs and no possible full sibs were identified in this study. This means that a male's sisters are probably less closely related to him than to his mother and are therefore

less likely to affiliate with him if his presence is of little benefit to them. It thus appears that the greatest advantage to males of staying permanently in their natal groups is that it increases their fitness directly, and that staying is facilitated by mothers.

Given my findings, the most salient question concerning the social structure of resident killer whales is not why males don't disperse permanently, but why they don't rove temporarily. Because residents signal acoustically over long distances, a male that left his matriline to escort other groups containing potential mates would not risk losing contact with his matriline for long periods. Yet, resident males almost always remain near their matrilines (Bigg et al. 1990, Matkin et al. 1999b, Ford et al. 2000). During multi-pod aggregations, unrelated males sometimes travel in all male groups, but these rarely persist for more than a few hours before the males rejoin their matrilines (Bigg et al. 1990, Rose 1992, Matkin et al. 1999b). Since the costs associated with temporary male dispersal appear to be low, the benefits are likely low as well—that is, males that travel alone to seek receptive females do not mate significantly more frequently than those that remain with their matriline. The simplest way to explain this is that female preference is higher for non-pod males that arrive as part of a matriline than it is for males that arrive alone. Such a preference could arise in at least three ways. First, females may use mating to establish and maintain social relationships with groups with which they share foraging areas. Marriage exchanges play a similar and important role in promoting and maintaining peaceful or co-operative relationships among many human tribal societies (Yengoyan 1968, Richerson and Boyd 1998). If social cohesion is influenced by mating, females might be expected to mate with more than one male during associations between pods. Multiple mating does appear likely in killer whales, based on testis size to body size ratios (Connor 2000). Second, female preference may be influenced by the number and quality of a male's matrilineal relatives, in a "good genes" form of sexual selection. Third, females may prefer males that arrive with group members because they are able to determine their relatedness more reliably, and hence minimize inbreeding. This point is discussed further below.

### *Pod fission and acoustic divergence*

Bigg et al. (1990) noted that when a matriarch dies leaving two or more daughters with their own offspring, the sister matriline gradually divide socially. They hypothesized that new pods form as a result of fission between groups of matrilines in large pods. Ford (1991) developed this model further, by hypothesizing that pod fission is followed by the slow divergence of the acoustic repertoires of descendent pods, such that the extent of acoustic similarity between pods is negatively correlated with the time since their separation, and hence with their genetic distance. According to Ford's model, acoustic clans consist of pods that share more recent maternal ancestors with each other than with the pods of other clans. My finding of a negative correlation between genetic distance and acoustic similarity in A-clan of the northern residents is fully concordant with the pod-fission hypothesis of Bigg et al. (1990) combined with the acoustic divergence hypothesis of Ford (1991). Furthermore, the findings are difficult to reconcile with the alternative hypotheses that pods form from groups of migrant individuals and/or that call repertoires diverge rapidly at the time of pod formation. A third and unlikely hypothesis is that acoustic repertoires are under direct genetic control. This would require an unusual mechanism of strict maternal inheritance because most calves are fathered by non-pod males. In addition, Ford (1991) presented several lines of evidence that resident killer whales learn their repertoires by imitation and learning.

### *Mating patterns with respect to acoustic clan membership*

One of my most striking findings is that most breeding occurs between and not within acoustic clans in the northern residents. This conclusion followed from the paternity analysis, in which most calf/candidate male matches were between clans. It is also consistent with the negative  $F_{is}$  estimator from the clan/subpopulation analysis which indicates that clans are more heterozygous than would be expected if mating were random. Since northern resident clans are significantly differentiated from each other ( $F_{st} > 0$ , Table 4.1), clan exogamy (outside mating) is expected to increase average heterozygosity beyond the level that would result from pod exogamy alone. Since resident killer whale subpopulations have small effective population sizes (c. 70 individuals, Chapter 3), such a

mating system is likely of significant selective value to females. It could be imagined, however, that it is vulnerable to cheating. If calls are the primary indicator of clan membership, then within-clan males could manipulate female preferences by imitating the calls of other clans. I believe that such a strategy would rarely be successful. By the time a female has reached reproductive age she has likely encountered all of the members of her subpopulation repeatedly (as discussed in Chapter 3) and has had ample opportunity to learn which matriline has similar calls. By only engaging in courtship with males that are accompanied by a matriline, she reduces the probability of failing to detect cheater males.

In contrast to the northern residents, I found no evidence of acoustic clan exogamy in the southern Alaskan residents. My sample of calves in this group with matching fathers was small (five), but in three cases the matches were within the clan. In addition, I did not detect excess heterozygosity indicative of exogamy within the clans in this subpopulation (i.e.,  $F_{is}$  was not significantly less than 0, Table 4.1). The southern Alaskan resident clans are large, containing an average of more than 180 individuals compared to 70 and 80 for the northern residents and southern residents, respectively. Each of the southern Alaskan resident clans contains groups of pods with substantially different (although not discrete) repertoires (Yurk et al. in prep). It is therefore likely that females can use dialect differences to avoid consanguineous matings in this subpopulation at the sub-clan as opposed to the clan level.

Northern residents and southern Alaskan residents also differ in the degree of genetic distance among their acoustic clans. Differentiation is highest in the northern residents, based on overall and pairwise  $F_{st}$  estimates (Tables 4.1 and 4.2). This pattern could be explained if the clans developed allopatrically, as proposed by Ford (1991), and the northern resident clans became sympatric more recently than the southern Alaskan residents. This explanation is not entirely satisfying however, since the lack of dispersal between clans in the southern Alaskan residents should maintain positive  $F_{st}$  over long periods.

Alternatively, the pattern may reflect differences in the demographic history of the two subpopulations. For example, if one of the southern Alaskan resident acoustic clans was recently founded by a single immigrant pod and grew rapidly while outbreeding, little differentiation between it and the original clan would be expected at nuclear loci.

Interestingly, the two Alaskan clans have different mitochondrial D-loop haplotypes (Chapter 3). AB-clan is identical to all three clans of the northern residents, and AD-clan is identical to J-clan of the southern residents, so potential founders for each clan were likely nearby. The separation of southern resident / AD-clan ancestors likely occurred earlier or is more complete than the separation of northern resident / AB-clan ancestors based on the relative magnitude of their pairwise *Fst*'s (Table 4.2).

#### *Origin and function of acoustic clans*

My findings are consistent with the hypothesis that acoustic clans differentiated allopatrically (Ford 1991), but they do not rule out sympatric mechanisms of clan formation. The allopatric model assumes that populations that are spatially separated eventually develop independent vocal traditions. Acoustic clans are the result of founding events that bring pods with different acoustic traditions together, and thus provide a historical record of social fusion. The model does not require that dialects play a role in mating preferences. I propose an alternative (but non-exclusive) mechanism of clan formation, one that operates in sympatry and is driven by dialect-dependent mating preferences. According to this hypothesis, the repertoires of the pods in a clan slowly diverge over time, and their average relatedness declines due to matings outside the clan. As a result, inbreeding costs associated with intra-clan mating also decline, especially for the least related (and hence least acoustically similar) pods. It eventually becomes advantageous for pod members to maximize differences between their dialect and those of their least similar clan mates in order to increase their pool of potential mates. Difference in repertoires could be achieved relatively quickly by increasing the rate of innovation and by pruning shared calls from the repertoire. Sympatric clan formation by the mechanism described above could be driven by a simple rule: minimize the rate of acoustic divergence from acoustically similar clan mates until a threshold level of acoustic divergence is reached, then maximize it. Deecke et al. (in press) described the occurrence of parallel changes in call types shared by two closely related matrilineal groups, as predicted by this rule. The sympatric clan formation hypothesis suggests that apparent differences in the mating patterns of the northern resident and southern Alaskan residents with respect to clan membership reflects differences in their stage in the cycle of

clan formation, and predicts that the southern Alaskan resident sub-clans discussed above will evolve into discrete acoustic clans.

The division of populations into sympatric, culturally-maintained groups that breed exogamously is common in human societies, especially small ones (Murdock 1949, p. 47). The Haida, Tlingit and Tsimshian tribes of British Columbia, for example, are divided into two, two and four totemic clans, respectively. Clan membership is inherited maternally, and marriages were traditionally sanctioned between, not within, clans (Garfield, 1939). The Jirel people of Nepal are divided into 22 exogamous clans with patrilineal membership (Williams-Blangero 1990). A variety of exogamous clan systems limited consanguineous matings in Australian Aboriginal tribes. In one system, the children of marriage partners from different clans belonged to a third clan and subsequently married individuals from a fourth (Berndt and Berndt 1985 pp. 46-49). In human societies characterised by clan exogamy, marriage rules were transmitted and enforced culturally (Murdock 1949, pp. 82-84). In northern resident killer whales, acoustic clan exogamy can be accounted for without resorting to cultural rules. The most parsimonious explanation is that it is a simple consequence of inbreeding avoidance based on female preferences for males with different acoustic repertoires. This explanation predicts that in resident subpopulations with only a single clan, such as the southern residents, most matings should occur between the most acoustically-dissimilar pods. My sample of southern residents was too small to make this test, but it could be done readily in the future because significant variation exists in the acoustic similarity of southern resident pods (Ford 1991). Interestingly, each of the three intra-clan paternity matches found in the southern Alaskan residents were between the most acoustically distinct pods in their clan (based on Yurk et al., in prep.).

#### *Subpopulation endogamy*

In contrast to outbreeding at the pod and clan levels, the paternity analysis suggests that mating between subpopulations is rare. The fixation index values for subpopulations with respect to the entire populations are consistent with this finding. In particular  $F_{st}$  and  $F_{it}$  were both significantly greater from zero, as expected if the populations are genetically segregated and breeding rarely occurs between them. The lack of gene flow between

contiguous, ecologically similar populations is unusual in animals, and is difficult to ascribe to any genetic mechanism. Indeed, mating between such populations would likely bring genetic benefits, as I argued elsewhere (Chapter 3). The lack of such gene flow could reflect costs of inter-population contact associated with (1) aggressive conflict stemming from resource or mate competition, (2) resource competition during the period of association for mating, (3) future competition arising from the transfer of local knowledge during the period of association, and/or (4) disease transmission (Diamond 1992, p. 228). I offer a different kind of explanation here. Because resident killer whales remain in their natal groups for life, the fate of individuals is tied to the fate of the group much more strongly than in most species, and the force of group selection must be unusually strong. Group selection can favour traits that benefit the group at the expense of the individual, including culturally-transmitted behaviours (Feldman and Laland 1996), which in turn drive evolution of in-group favouritism (Richerson and Boyd 1998). This favouritism may restrict association and hence mating between subpopulations. According to this view, the minimum size of viable subpopulations is the number that is sufficient to prevent inbreeding depression, and the maximum is ultimately dependent on resource distribution, since the maintenance of group identity presumably depends on members coming into contact periodically (as discussed in Chapter 3).

### *Conclusions*

The analysis of resident killer whale mating systems presented here paints a picture of a population in which gene flow occurs along lines defined by a hierarchical social system. Consanguineous breeding is prevented by mating outside the matriline and pod; inbreeding is further avoided in one subpopulation by mating between acoustic clans; and mating between subpopulations is restricted. The only known identifying characteristics of acoustic clans are their distinctive dialects, so a causal link between mating patterns and acoustics is likely. This linkage is consistent with the limited evidence presented here that even intra-clan matings tend to take place between acoustically dissimilar pods. Boyd and Richerson (1987) noted that human social groups are invariably defined and marked by culturally-transmitted symbolic boundaries such as body ornamentation, dialects, and ritual systems.



Resident killer whales also appear to have a culturally-maintained social system, with call repertoires serving to directly define and delineate at least two levels of social grouping: the pod and the clan. Members of a clan undoubtedly become familiar with the repertoires of other clans within their subpopulation, thus repertoires also delineate subpopulation membership. Cultural differences also distinguish the resident killer whale population from sympatric transient killer whales, which prey on marine mammals and have distinct feeding, social, and acoustic behaviours (Ford 1984, Barrett-Lennard et al. 1996a). It would thus appear that the most important factors driving the evolution of social complexity in killer whales are kin-selected behaviours arising from the lack of dispersal of either sex, and both inbreeding avoidance and subpopulation cohesion based on cultural markers of group membership.

## CHAPTER FIVE

### General Conclusions

One well-established convention of modern scientific natural history is to eschew anthropomorphism at all costs. I have therefore found myself in the uncomfortable position throughout my Ph.D. research of drawing repeated analogies between human and killer whale social organization. I have tried to do it critically, but several key features of killer whale social organization simply *do* bear striking resemblance to features of some human societies, and little resemblance to those other well-studied species. Nevertheless, I do not expect my study to become a poster child for rampant anthropomorphism. Rather, I hope the points of similarity between killer whale and human societies will stimulate interest in the links between ecological specialization, culture, and the emergence of specific types of social organization.

This thesis is organized into three main parts. The first part (Chapter 2) is a description of the method I used to collect skin samples, and hence DNA, from identified killer whales in the northeastern Pacific Ocean. The second part (Chapter 3) presents findings from DNA analysis that shed light on the patterns of social segregation within and between killer whale populations. The third part (Chapter 4) presents findings from DNA analysis that shed light on mating patterns, inbreeding, and inbreeding avoidance in the resident population. In this chapter, I briefly summarize the main findings from the thesis and contrast some of the key findings with those obtained in studies of other social mammals.

#### Biopsy system

Some of the earliest DNA-based studies of population identity were performed on cetaceans, reflecting the fact that many species are distributed over vast areas. Prior to this study, DNA samples were obtained from animals killed in commercial or scientific whaling operations, or from skin biopsies obtained using arrows fitted with cylindrical punch tips and projected with longbows, crossbows, or harpoon-type guns (Winn et al. 1973, Kasamatsu et al. 1991, Lambertson et al. 1994). The arrows weighed 50 - 350 g and were fitted with tether lines for retrieval. These systems seemed unnecessarily invasive for a relatively small cetacean such

as the killer whale, and I developed an alternative system for this study with the help of Graeme Ellis and Terry Gjernes (Canadian Department of Fisheries and Oceans). The system uses lightweight (12 g) tetherless floating darts fired with a pneumatic rifle, and is modified from a system designed for terrestrial mammals by Karesh et al. (1987). The dart tip incorporates a cylindrical punch fitted with a barbed shaft (referred to as a dental broach) which retains the skin plug when the dart bounces off the whale.

The dart system proved to have a high success rate relative to earlier systems in acquiring skin and blubber samples. Part of this efficiency was due to the accuracy of the darts, which were stabilized in flight by spin imparted by rifling of the gun barrel. In addition to their accuracy, the darts excised and retained samples more consistently than most earlier cetacean systems, which I attributed to use of dental broaches. Previous authors assessed the reactions of whales to strikes by biopsy darts by noting a) immediate responses, such as shaking or diving, and b) changes in behavioural patterns (such as respiration rates and direction of travel). Unfortunately, changes in behavioural patterns are difficult to interpret objectively. For example, it is not known whether a change in respiration rate indicates severe or mild disturbance. I made note of immediate behavioural responses but departed from tradition and further assessed the effect of darting by a) noting the position of the dart strike and searching for signs of wound complication in subsequent sightings of the animal, and b) determining whether whales avoided the research boat more actively after being biopsied than they did before. Measuring avoidance directly made it possible to answer a practical question objectively: will biopsy sampling make killer whales more difficult to study (or watch recreationally) in future? I reasoned that if avoidance did not increase, it would indicate that the disturbance of the darting was minor and/or that the whales failed to associate the impact of the dart with the presence of the boat, while the opposite would indicate that both conditions were true.

Most whales showed only slight responses to biopsy strikes, and could be re-approached both immediately after darting and after periods of up to one year. The strongest immediate reactions to dart strikes or misses were from individuals that had been evasive prior to the darting. Most of these were relatively old individuals, and may have had negative

interactions with boats in the past. No evidence of wound complication was seen. At the time of writing, 340 killer whale biopsy samples have been taken using the method in Alaska and British Columbia by myself and my colleagues; it has also been used successfully in studies of at least four other cetacean species (bottlenose dolphin and beluga, gray, and humpback whale). The findings presented in this dissertation are based on the analysis of 269 samples collected prior to 1999.

### DNA analysis

Both mitochondrial and nuclear DNA markers were used in this study. I sequenced the entire mitochondrial D-loop (the most variable region of the mitochondrial genome in mammals) from one individual from each killer whale matriline sampled. The D-loop is 919 nucleotides long in the killer whale, which is somewhat longer than the length that could be reliably sequenced with the equipment I used. Consequently, I sequenced from both directions, and used the substantial region of overlap as a check of the accuracy of each reaction. As with some other odontocete cetaceans (Whitehead 1998) mitochondrial diversity was low, and most putative sub-populations had a single version of the sequence. I also analysed microsatellite markers, which are highly variable regions of non-coding nuclear DNA. Both maternal and paternal microsatellite alleles are resolved during analysis, which makes them well-suited to parental testing. I analysed all samples at each of 11 microsatellite loci. An average of 7.8 alleles were identified per locus.

### Social segregation within and between killer whale populations

Bigg (1982) presented the first evidence that killer whales inhabiting the coast of British Columbia live in two sympatric, socially isolated populations. It is now known that the populations, referred to as residents and transients, feed on different prey (fish and marine mammals respectively; Ford et al. 1998), and differ in social organization (Ford et al. 2000). They also differ slightly in morphology (Bigg et al. 1987, Baird and Stacey 1988), and are differentiated at both mitochondrial and nuclear DNA loci (Stevens et al. 1989, Hoelzel 1991, Hoelzel et al. 1998). A third group referred to as the offshores is poorly studied, but its diet is known to include fish, and it is usually sighted further from the coast than either

residents or transients (Ford et al. 1994). I conducted a detailed analysis of genetic differentiation within and among the resident and transient populations, and a more limited analysis of the offshore population. My findings are reported in Chapter 3 and are summarized here.

(1) The resident and transient populations are highly differentiated. Successful female immigration between the two populations can be ruled out on the basis of fixed mitochondrial differences, and differences in nuclear DNA allele frequencies indicate that male-mediated gene flow between the populations is negligible. Because residents and transients are sympatric and are known to be reproductively compatible in captivity, it appears that the barriers to gene flow arise from social factors alone. I argue that the transmission of cultural traits such as vocal traditions and suites of foraging behaviours maintains the ecological separation of sympatric residents and transients and promotes the social cohesion of each population, and is the principal factor preventing them from interbreeding.

(2) The resident and the transient populations are each subdivided into three genetically differentiated subpopulations within British Columbia and southern Alaska. The mitochondrial analysis ruled out female dispersal between most of the subpopulations, and differences in microsatellite allele frequencies suggest that male-mediated gene flow is also restricted, but likely less complete than between residents and transients.

(3) Because the resident/transient dichotomy is replicated in British Columbia and southern Alaska, it was not known prior to this study whether feeding traditions had diverged more than once. This study showed that the transient subpopulations were more closely related to each other at both nuclear and mitochondrial loci than they were to the resident subpopulations and vice versa, consistent with a single divergence. The results provide no indication of whether the initial divergence occurred sympatrically or allopatrically, but suggest that it is widening in its present condition of sympatry.

(4) The offshore group was not found to be closely related to either the residents or the transients. Comparison of nuclear and mitochondrial markers suggest that it initially

diverged from ancestral residents but has subsequently experienced more male-mediated gene flow with transients than with residents.

(5) Field studies indicate that neither sex disperses from the natal group in residents. I found that two acoustic clans of southern Alaskan resident killer whales (Yurk et al, in prep.) that associate freely and intermate have distinct mitochondrial haplotypes, which suggests that the lack of dispersal is typical of the recent history of the population.

Based on the patterns of segregation described above, I propose that killer whale subpopulations arise sympatrically by a process of social fission. According to the model, when a subpopulation expands beyond a critical size, pods that forage at different extremes of its range encounter each other less and less often, and eventually cease to recognise each other as members of the same subpopulation. A range boundary eventually forms between them, and pods that usually forage in the central part of the original range are eventually drawn into one of the new subpopulations.

#### Mating systems in resident killer whales

Resident killer whales live in hierarchically structured subpopulations. The fundamental unit is the matriline, which contains descendants of an old or recently deceased female. Neither sex disperses from its natal matriline, a situation unique among well-studied mammals with the exception of the long-finned pilot whale (Amos et al. 1993). Groups of matriline that associate frequently are believed to be closely related maternally, and are referred to as pods. An acoustic clan is a group of pods that share part of their vocal repertoire. Pods associate within and between acoustic clans within their subpopulation, but rarely associate with pods from other subpopulations. This nested, multi-level system of social organisation is also extremely unusual among mammals. Mating and overt courtship behaviours among killer whales are rarely seen in the wild. Chapter 4 of this dissertation presents the findings of genetic analyses intended to elucidate mating patterns, and asks specifically about inbreeding and gene flow with respect to each level of social organisation. It also examines the accuracy of observational studies in identifying maternal relationships, and tests hypotheses concerning pod formation and acoustic repertoire divergence.

Three types of analysis were performed to investigate resident mating systems. The first was a detailed set of microsatellite genotype comparisons that tested paternity of calves and directly asked whether fathers tend to be within the same matriline, pod, clan or subpopulation as their offspring. Similar comparisons were used to test whether incorrect calf/mother assignments had been made in observational studies. The second was an analysis of microsatellite allele frequency distributions (based on Wright's  $F$ -statistics) that asked whether mating occurs randomly across various levels of social organization, and if not, whether mating is inbred or outbred with respect to those levels. The third compared pairwise genetic distances between pods within an acoustic clan to the similarity of their acoustic dialects (as determined by Ford, 1984).

The accuracy of observational studies in assigning maternity based on associations between calves or juveniles and adult females was high (of 69 assignments, none were incorrect in the genotype comparisons). I found no potential paternal matches within matriline and only one of 19 within a pod. It therefore appears that matings occur during temporary associations between pods, and that incestuous breeding is avoided in this manner rather than by dispersal. In the northern resident subpopulation, the majority of paternal matches were between calves and males from different acoustic clans. This pattern presumably results from mate choice as well, and suggests that vocal repertoires play a central role in mating preferences. The tendency toward outbreeding appears to end at the subpopulation level, with most matches being between individuals from the same subpopulation.

The results of the  $F$ -statistic analysis were congruent with the findings from the direct paternity tests. Pods were more heterozygous than expected from random mating expectations, consistent with a pattern of outbreeding, and inconsistent with inbreeding. Clans in the northern resident subpopulation were significantly differentiated, as expected if maternal relatives do not disperse, but they were also more heterozygous than expected if mating was random. There was no evidence of outbreeding at the subpopulation level, and resident subpopulations were more strongly differentiated than were any of the other hierarchical levels. The social organisation of resident killer whale subpopulations resembles certain clan-based human tribal societies in which inbreeding is minimized by

incest taboos and by socially-imposed marriage rules prohibiting individuals from mating within their natal clans.

Bigg et al. (1990) proposed that new pods arise by fission, which occurs between groups of closely related matriline. Ford (1991) developed the model further by proposing that pod fission is followed by a gradual reduction in the acoustic similarity of descendent pods, and therefore acoustic similarity and genetic relatedness are correlated for the pods within an acoustic clan. I tested the prediction for the most-thoroughly-sampled acoustic clan using acoustic similarity measures from Ford (1984) and microsatellite-based genetic distances, and found that it held. Not only did this finding support the model, but it is difficult to reconcile with any plausible alternative models.

Ford (1991) proposed that the presence of more than one acoustic clan in a subpopulation is indicative of multiple founding events by the members of populations with independent acoustic traditions. My findings are consistent with this model in the case of the southern Alaskan residents, in which the two clans have different mitochondrial haplotypes, each of which matches a different resident subpopulation elsewhere within the study area. In the northern residents, each of the three clans has the same mitochondrial haplotype, and there is no direct evidence of separate founding events. I therefore proposed a sympatric mechanism of clan formation based on the assumption that mating preferences are negatively correlated with acoustic similarity. According to the model, when clans are small there is a selective advantage to inter-clan mating to avoid inbreeding. This advantage declines as clans grow, especially if most intra-clan matings are between the most acoustically dissimilar (and hence least closely related) pods in the clan. It is therefore selectively advantageous for pod members to maximize the differences between their call repertoire and those of the least acoustically similar pods in their clan, in order to increase their pool of potential mates. Repertoire divergence is achieved by increasing the rate of call innovation and pruning shared calls from the repertoire, and eventually results in the fission of the original clan.



## Summary and conclusions

Killer whale populations in the northeastern Pacific Ocean show a remarkable degree of subdivision. Two reproductively isolated populations with non-overlapping diets are fully sympatric, in what appears to be a classic case of ecological niche partitioning. Each is divided into genetically differentiated parapatric subpopulations with an average effective population size of approximately 70 individuals. Gene flow between subpopulations is restricted. The so-called resident population is characterised by an unusual social system in which a mother's male and female offspring remain with her for life. Consanguineous matings are rare, and inbreeding is avoided effectively by a system of mate choice that appears to hinge on the fact that acoustic repertoire similarity and relatedness are correlated. Since acoustic repertoires and feeding traditions are transmitted culturally, the species is one in which gene-culture coevolution (Feldman and Laland 1996) is likely.

The main features of killer whale social organisation as revealed in this and earlier studies is not mirrored closely in any other species that has been studied in depth. Sperm whales and elephants, for example, are long-lived and behaviourally sophisticated animals with a matrifocal social structure similar to that of the killer whale, but males of both species disperse at maturity (Whitehead 1993, Moss 1988) and there is no evidence of hierarchical levels of population structure. Primate social interactions are complex and there is good evidence of cultural transmission in some species (Nishida 1987, Whiten et al. 1999), nevertheless inbreeding appears to be prevented by sex-biased dispersal (Pusey and Packer 1987). Dominance hierarchies are common in primates (Walters and Seyfarth 1987) but discrete hierarchical levels of social organisation have not been identified. Some insect societies are highly organized, but their structure comprises a set of discrete castes (Wilson 1971), rather than a nested hierarchy as in killer whales. The long-finned pilot whale appears to be similar to resident killer whales in that individuals remain within their pods but mate outside them (Amos et al. 1993), but hierarchical levels of organisation above or below the pod level have not been described.

The most obvious parallels to killer whale social organisation can be found in certain human societies, as I touched on at the outset of this chapter. The three clearest

examples are the clan-based mating systems referred to above, the existence of sympatric ethnic groups that coexist without merging, and nested hierarchies such as family / village / clan / tribe that resemble the matriline / pod / clan / subpopulation structure of resident killer whale societies. These three parallels are likely rooted in the fact that both species are large-brained predators that transmit information culturally. In the first example, clan based mating systems may arise either through a form of cultural group selection (Boyd and Richerson 1985) or more simply as an extension of female preferences for certain cultural traits as I proposed in Chapter 4, but in either case they depend on the cultural transmission of traditions. In the second example, stable sympatric populations must be readily distinguishable and have different specializations to avoid competition and conflict. Both would appear to be readily accomplished in large-brained (hence behaviourally versatile) species with vertically transmitted cultural traditions (Boyd and Richerson 1987). In the third example, nested hierarchies afford individuals the ability to adjust their group size depending on variable resources and risks. For example, higher hierarchical levels likely provide a social alliance for defence against raiding or invading conspecifics or for killing large prey, while lower levels provide efficient groups for hunting small or dispersed prey (Guinet et al. 2000).

The feature of killer whale social organization that is hardest to understand, and one for which there are no obvious human parallels, is the non-dispersal of residents. I have shown that residents outbreed very efficiently in the complete absence of dispersal. What is puzzling is that no other mammals (with the likely exception of the long-finned pilot whale, Amos et al. 1993) are known to have developed the same way of reaping the benefits of remaining permanently in the natal group without suffering inbreeding costs. Inbreeding avoidance behaviours are likely to be stronger in females than in males, because of inherent differences between males and females in the variability of reproductive success (eggs are costly, sperm is cheap). Therefore, the absence of intra-pod matings found in this study suggests that the mating system is based on female choice. Female choice systems are common in mammals, but so are coercive matings (Clutton-Brock and Parker 1995). My

results suggest that successful coercive matings must be extremely rare in killer whales, a condition that is presumably a prerequisite for females to tolerate the presence of closely related adult males.

I end my dissertation with three speculations about why coercive matings may be rare in killer whales. First, such matings may be physically difficult in a three dimensional world where males are unable to physically constrain females. Homosexual activity, including penile intromissions, takes place frequently in groups of male killer whales (Rose 1992, Matkin et al. 1999b). An adaptive function of this behaviour may be that it helps males learn difficult mating skills. The best example of coercive matings in cetaceans occurs in a population of bottlenose dolphins in Australia (Connor et al. 1992) where mating takes place in shallow water that may restrict female escape options. Second, killer whales are capable of attacking and killing large cetaceans, thus females are likely dangerous to males. In addition, the large size of male killer whales relative to females may put them at a relative disadvantage in male-female conflicts. Alexander et al. (1979) noted that reverse sexual size dimorphism (larger females than males) exists in many species in which inter-male or male-female conflict occurs in three dimensional environments, such as water. They concluded that agility is probably of greater advantage than size in such conflicts. Third, female resident killer whales usually live in groups containing other females, which may serve as coalitions to defend against males (see Smuts and Smuts 1993). All three speculations predict that male killer whales are the most polite and obsequious of suitors—which unfortunately has not been tested.

## BIBLIOGRAPHY

- Aguilar A. & Nadal, J. 1984 Obtención de biopsias hipodérmicas de cetáceos en libertad. *Investigación Pesquera* **48**, 23-29.
- Alexander, R.D., Hoogland, J.L., Howard, R.D., Noonan, K.M. & Sherman, P.W. 1979 Sexual dimorphism and breeding systems in pinnipeds, ungulates, primates, and humans. In *Evolutionary Biology and Human Social Behavior: an Anthropological Perspective* (Chagnon, N.A. & Irons, W.) pp.402-435. North Scituate, Mass.: Duxbury Press.
- Amos, B., Schlötterer, C. & Tautz, D. 1993 Social structure of pilot whales revealed by analytical DNA profiling. *Science* **260**, 670-672.
- Amos, W. 1999 Culture and genetic evolution in whales. *Science* **284**, 2055.
- Amos, W. & Hoelzel, A.R. 1991 Long-term preservation of whale skin for DNA analysis. *Report of the International Whaling Commission Special Issue* **13**, 99-103.
- Anderson, I. 1987 Will curiosity kill the whale? *New Scientist* 29 January 1987: 44-50
- Arnason, U., Gullberg, A. & Widegren, B. 1991 The complete nucleotide sequence of the mitochondrial DNA of the fin whale, *Balaenoptera physalus*. *Journal of Molecular Ecology* **33**, 556-568.
- Baird, R.W., Abrams, P.A. & Dill, L.M. 1992 Possible indirect interactions between transient and resident killer whales: implications for the evolution of foraging specializations in the genus *Orcinus*. *Oecologia* **89**, 125-132.
- Baird, R.W. & Dill, L.M. 1995 Occurrence and behaviour of transient killer whales: seasonal and pod-specific variability, foraging behaviour, and prey handling. *Canadian Journal of Zoology* **73**, 1300-1311.
- Baird, R.W. & Dill, L.M. 1996 Ecological and social determinants of group size in transient killer whales. *Behavioral Ecology* **7**, 408-416.
- Baird, R.W. & Stacey, P.J. 1988 Variation in saddle patch pigmentation in populations of killer whales (*Orcinus orca*) from British Columbia, Alaska, and Washington State. *Canadian Journal of Zoology* **66**, 2582-2585.
- Baker, C.S., Perry, A., Bannister, J.L., Weinrich, M.T., Abernethy, R.B., Calambokidis, J., Lien, J., Lambertsen, R.H., Urban Ramirez, J., Vasquez, O., Clapham, P.J., Alling, A., O'Brien, S.J. & Palumbi, S.R. 1993 Abundant mitochondrial DNA variation and world-wide population structure in humpback whales. *Proceedings of the National Academy of Science USA* **90**, 8239-8243.
- Baptista, L.F. & Trail, P.W. 1992 The role of song in the evolution of passerine diversity. *Systematic Biology* **41**, 242-247.

- Barrett-Lennard, L.G., Heise, K.A., Saulitis, E.L., Ellis, G.M. & Matkin, C.O. 1995 *The impact of killer whale predation on Steller sea lion populations in British Columbia and Alaska*. Report of the Marine Mammal Research Consortium, Fisheries Centre, University of British Columbia, 6248 Biological Sciences Road, Vancouver, BC, V6T-1Z4, Canada.
- Barrett-Lennard, L.G., Ford, J.K.B. & Heise, K.A. 1996a The mixed blessing of echolocation: differences in sonar use by fish-eating and mammal-eating killer whales. *Animal Behaviour* **51**, 553–565.
- Barrett-Lennard, L.G., Smith, T.G. & Ellis, G.M. 1996b A cetacean biopsy system using lightweight pneumatic darts, and its effect on the behaviour of killer whales. *Marine Mammal Science* **12**, 14–27.
- Berndt, R.M. & Berndt, C.H. 1985 *The world of the first Australians*. Adelaide: Rigby.
- Berzin, A.A. & Vladimirov, V.L. 1983 A new species of killer whale (Cetacea: Delphinidae) from Antarctic waters (transl. by S. Pearson) *Zoologicheskii Zhurnal* **62**, 287–295.
- Bigg, M.A. 1982 An assessment of killer whale (*Orcinus orca*) stocks off Vancouver Island, British Columbia. *Report of the International Whaling Commission* **32**, 625–666.
- Bigg, M.A., Ellis, G.M., Ford, J.K.B. & Balcomb, K.C.III. 1987 *Killer whales: A study of their identification, genealogy and natural history in British Columbia and Washington State*. Nanaimo, British Columbia: Phantom Press.
- Bigg, M.A., Olesiuk, P.F., Ellis, G.M., Ford, J.K.B. & Balcomb, K.C.III. 1990 Social organization and genealogy of resident killer whales (*Orcinus orca*) in the coastal waters of British Columbia and Washington State. *Report of the International Whaling Commission Special Issue* **12**, 383–405.
- Boyd, R. & Richerson, P.J. 1985 *Culture and the Evolutionary Process*. Chicago: University of Chicago Press.
- Boyd, R. & Richerson, P.J. 1987 The evolution of cultural markers. *Cultural Anthropology* **2**, 65–79.
- Brown, M.R., Corkeron, P.J., Hale, P.T., Schultz, K.W. & Bryden, M.M. 1994 Behavioral responses of east Australian humpback whales *Megaptera novaeangliae* to biopsy sampling. *Marine Mammal Science* **10**, 391–400.
- Brown M. W., S. D. Kraus, & D. E. Gaskin. 1991 Reaction of North Atlantic Right whales (*Eubalaena glacialis*) to skin biopsy sampling for genetic and pollutant analysis. Report of the International Whaling Commission Special Issue **13**, 81–89.
- Buchanan, F.C., Friesen, M.K., Littlejohn, R.P. & Clayton, J.W. 1996 Microsatellites from the beluga whale *Delphinapterus leucas*. *Molecular Ecology* **5**, 571–575.
- Chesser, R.K. 1991 Gene diversity and female philopatry. *Genetics* **127**, 437–447.

- Clapham P. J. & Mattila, D. K. 1993. Reactions of humpback whales to skin biopsy sampling on a West Indies breeding ground. *Marine Mammal Science* **9**, 382-391.
- Clutton-Brock, T.H. & Parker, G.A. 1995 Sexual coercion in animal societies. *Animal Behaviour* **49**, 1345-1365.
- Cohen, J. 1988 *Statistical power analysis for the behavioral sciences* 2nd edition. Hillsdale, New Jersey: Lawrence Erlbaum Associates.
- Connor, R.C., Smolker, R.A. & Richards, A.F. 1992 Two levels of alliance formation among male bottlenose dolphins (*Tursiops* sp.). *Proceedings of the National Academy of Science USA* **89**, 987-990.
- Connor, R.C. 2000 Male reproductive strategies and social bonds. In *Cetacean Societies* (Mann, J., Connor, R.C., Tyack, P.L. & Whitehead, H.) pp.247-269. Chicago: University of Chicago Press.
- Dahlheim, M.E. 1997 *A photographic catalog of killer whales, Orcinus orca, from the central Gulf of Alaska to the southeastern Bering Sea*. NOAA Technical Report NMFS 131 Seattle, Washington: US Department of Commerce.
- Dahlheim, M.E., Ellifrit, D.K. & Swenson, J.D. 1997 *Killer whales of southeast Alaska*. Seattle, Washington: National Marine Mammal Laboratory.
- Deecke, V.B., Ford, J.K.B. & Spong, P. 1999 Quantifying complex patterns of acoustic variation: use of a neural network to compare killer whale (*Orcinus orca*) dialects. *Journal of the Acoustical Society of America*. **105**, 2499-2507.
- Deecke, V., Ford, J.K.B. & Spong, P. *in press* Dialect change in resident killer whales: implications for vocal learning and cultural transmission. *Animal Behaviour*.
- Diamond, J.M. 1992 *The Third Chimpanzee*. N.Y.: HarperCollins.
- Duffield, D.A., Odell, D.K. & Andrews, B. 1995 Killer whale (*Orcinus orca*) reproduction at Sea World. *Zoo Biology* **14**, 417-430.
- Dobzhansky, T. 1973 Nothing in biology makes sense except in the light of evolution. *The American Biology Teacher* **35**, 125-129.
- Feldman, M.W. & Laland, K.N. 1996 Gene-cultural coevolutionary theory. *Trends in Ecology and Evolution* **11**, 453-457.
- Felsenstein, J. 1993 PHYLIP (Phylogeny Inference Package) version 3.5c. Distributed by the author. Department of Genetics, University of Washington, Seattle.
- Ford, J.K.B. 1984 Call traditions and dialects of killer whales (*Orcinus orca*) in British Columbia. Ph.D. Dissertation, University of British Columbia, Vancouver.
- Ford, J.K.B. 1989 Acoustic behaviour of resident killer whales (*Orcinus orca*) off Vancouver Island, British Columbia. *Canadian Journal of Zoology* **67**, 727-745.

- Ford, J.K.B. 1991 Vocal traditions among resident killer whales (*Orcinus orca*) in coastal waters of British Columbia. *Canadian Journal of Zoology* **69**, 1454–1483.
- Ford, J.K.B. & Ellis, G.M. 1999 *Transients*. Vancouver: University of British Columbia Press.
- Ford, J.K.B., Ellis, G.M. & Balcomb, K.C.III. 1994 *Killer Whales*. Vancouver: University of British Columbia Press.
- Ford, J.K.B., Ellis, G.M., Barrett-Lennard, L.G., Morton, A.B. & Balcomb, K.C.III. 1998 Dietary specialization in two sympatric populations of killer whales (*Orcinus orca*) in coastal British Columbia and adjacent waters. *Canadian Journal of Zoology* **76**, 1456–1471.
- Ford, J.K.B., Ellis, G.M. & Balcomb, K.C.III. 2000 *Killer Whales*. 2nd Ed. Vancouver: University of British Columbia Press.
- Garfield, V.E. 1939 Tsimshian Clan and Society. *University of Washington Publications in Anthropology* **7**, 167–340.
- Goldstein, D.B., Ruiz-Linares, A., Feldman, M. & Cavalli-Sforza, L.L. 1995 Genetic absolute dating based on microsatellites and the origin of modern humans. *Proceedings of the National Academy of Science, USA* **92**, 6270–6277.
- Goley, P.D. & Straley, J.M. 1994 Attack on gray whales (*Eschrichtius robustus*) in Monterey Bay, California, by killer whales (*Orcinus orca*) previously identified in Glacier Bay, Alaska. *Canadian Journal of Zoology* **72**, 1528–1530.
- Goodnight, K.F. & Queller, D.C. 1999 Computer software for performing likelihood tests of pedigree relationship using genetic markers. *Molecular Ecology* **8**, 1231–1234.
- Goudet, J. 1995 FSTAT version 1.2: a computer program to calculate *F*-statistics. *Journal of Heredity* **86**, 485–486.
- Grant, B.R. & Grant, P.R. 1996 Cultural inheritance of song and its role in the evolution of Darwin's finches. *Evolution* **50**, 2471–2487.
- Greenwood, P.J. 1980 Mating systems, philopatry, and dispersal in birds and mammals. *Animal Behaviour* **28**, 1140–1162.
- Guglielmino, C.R. 1996 Genetic structure in relation to the history of Hungarian ethnic groups. *Human Biology* **68**, 335–355.
- Guinet, C. 1990 Intentional stranding apprenticeship and social play in killer whales (*Orcinus orca*). *Canadian Journal of Zoology* **69**, 2712–2716.
- Guinet, C. 1992 Comportement de chasse des orques (*Orcinus orca*) autour des îles Crozet. *Canadian Journal of Zoology* **70**, 1656–1667.

- Guinet, C., Barrett-Lennard, L.G. & Loyer, B. 2000 Co-ordinated attack behavior and prey sharing by killer whales at Crozet Archipelago: strategies for feeding on negatively buoyant prey. *Marine Mammal Science* **16**, 829–834.
- Guo, S.W. & Thompson, E.A. 1992 Performing the exact test for Hardy-Weinberg proportion for multiple alleles. *Biometrics* **48**, 361–372.
- Hauge, X.Y. & Litt, M. 1993 A study of the origin of 'shadow bands' seen when typing dinucleotide repeat polymorphisms by the PCR. *Human Molecular Genetics* **2**, 411–415.
- Heise, K., Ellis, G.M. & Matkin, C.O. 1992 *A catalogue of the killer whales of Prince William Sound*. Homer, Alaska: North Gulf Oceanic Society.
- Hoelzel, A.R. 1991 Analysis of regional mitochondrial DNA variation in the killer whale; implications for cetacean conservation. *Report of the International Whaling Commission Special Issue* **13**, 225–233.
- Hoelzel, A.R., Dahlheim, M. & Stern, S.J. 1998 Low genetic variation among killer whales (*Orcinus orca*) in the Eastern North Pacific, and genetic differentiation between foraging specialists. *Journal of Heredity* **89**, 121–128.
- Hoelzel, A.R. & Dover, G.A. 1991 Genetic differentiation between sympatric killer whale populations. *Heredity* **66**, 191–195.
- Hoyt, E. 1984 *Orca, the whale called killer*. Camden East, Ontario: Camden House.
- Innis, M.A. & Gelfand, D.H. 1990 Optimization of PCRs. In *PCR Protocols* (Innis, M.A., Gelfand, D.H., Sninsky, J.J. & White, T.J.) pp.3–12. San Diego: Academic Press.
- Johnson, M.L. & Gaines, M.S. 1990 Evolution of dispersal: theoretical models and empirical tests using birds and mammals. *Annual Review of Ecology and Systematics* **21**, 449–480.
- Jurk, H., Barrett-Lennard, L.G., Ford, J.K.B., Saulitis, E., Matkin, C.O. & Heise, K. 1998. Clan structure of resident killer whales (*Orcinus orca*) in Prince William Sound Alaska: acoustic and genetic evidence. Abstracts of the World Marine Mammal Science Conference; Monaco, 20-24 January, 1998.
- Karesh, W. B., Smith, F. & Frazier-Taylor, H. 1987 A remote method for obtaining skin biopsy samples. *Conservation Biology* **1**, 261-262.
- Kasamatsu, F., Iwata, S. & Nishiwaki, S. 1991 Development of biopsy skin sampling system for fast swimming whales in pelagic waters. *Report of the International Whaling Commission* **41**, 555-557.
- Lambertsen R. H. 1987 A biopsy system for large whales and its use for cytogenetics. *Journal of Mammalogy* **68**, 443-445.



- Lambertsen, R.H., Baker, C.S., Weinrich, M.T. & Modi, W.S. 1994 An improved whale biopsy system designed for multi-disciplinary research. In *Nondestructive biomarkers in vertebrates* (Fossi, M.C. & Leonzio, C.) pp.219–244. Boca Raton, FL.: Lewis Publishers, CRC Press.
- Leatherwood, S., Matkin, C.O., Hall, J.D. & Ellis, G.M. 1990 Killer whales, *Orcinus orca*, photo-identified in Prince William Sound, Alaska, 1976 through 1987. *Canadian Field Naturalist* **104**, 362–371.
- Mantel, N. 1967 The detection of disease clustering and a generalized regression approach. *Cancer Research* **27**, 209–220.
- Marshall, T.C., Slate, J., Kruuk, L.E.B. & Pemberton, J.M. 1998 Statistical confidence for likelihood-based paternity inference in natural populations. *Molecular Ecology* **7**, 639–655.
- Mathews E. A. 1986 Multiple use of skin biopsies collected from free-ranging gray whales: sex chromatin analysis, collection and processing for cell culture, microbiological analysis of associated organisms, behavioural responses of whales to biopsying, and future prospects for using biopsies in genetic and biochemical studies. M.Sc. Thesis, University of California, Santa Cruz.
- Mathews, E.A., S. Keller, & D.B. Weiner. 1988 A method to collect and process skin biopsies for cell culture from free-ranging gray whales (*Eschrichtius robustus*). *Marine Mammal Science* **4**, 1-12.
- Matkin, C.O., Matkin, D.R., Ellis, G.M., Saulitis, E. & McSweeney, D. 1997 Movements of resident killer whales in southeastern Alaska and Prince William Sound, Alaska. *Marine Mammal Science* **13**, 469–475.
- Matkin, C.O., Ellis, G., Olesiuk, P. & Saulitis, E. 1999a Association patterns and inferred genealogies of resident killer whales, *Orcinus orca*, in Prince William Sound, Alaska. *Fishery Bulletin* **97**,900–919.
- Matkin, C.O., Ellis, G.M., Saulitis, E.L., Barrett-Lennard, L.G. & Matkin, D.R. 1999b *Killer Whales of Southern Alaska*. Homer, Alaska: North Gulf Oceanic Society.
- Mayr, E. 1942 *Systematics and the Origin of Species*. New York: Columbia University Press.
- Meggitt, M.J. 1965 *Lineage system of the Mae-Enga of New Guinea*. London: Oliver & Boyd.
- Minch, E., Ruiz-Linares, A., Goldstein, D., Feldman, M. & Cavalli-Sforza, L.L. 1995 MICROSAT. A program for calculating genetic distances from microsatellite data. Available at Internet site: <http://lotka.stanford.edu/microsat/microsat.html>.
- Morton A.B. 1990 A quantitative comparison of the behaviour of resident and transient forms of killer whales off the central British Columbia coast. *Report of the International Whaling Commission Special Issue* **12**,245–248.

- Moss, C. 1988 *Elephant memories*. New York: William Morrow and Company, Inc.
- Muir, D.C.G., Ford, C.A., Stewart, R.E.A., Smith, T.G., Addison, R.F., Zinck, M.E. & Beland, P. 1990 Organochlorine contaminants in belugas, *Delphinapterus leucas*, from Canadian waters. In *Advances in research on the beluga whale, Delphinapterus leucas* (Smith, T.G., St. Aubin, D.J. & Geraci, J.R.) *Canadian Bulletin of Fisheries and Aquatic Sciences* **224**, 165-190.
- Murdock, G.P. 1949 *Social Structure*. New York: MacMillan.
- Murray, B.W., Malik, S. & White, B.N. 1995 Sequence variation at the major histocompatibility complex locus DQB in Beluga whales (*Delphinapterus leucas*). *Molecular Biology and Evolution* **12**, 582-593.
- Nei, M. 1972 Genetic distance between populations. *American Naturalist* **106**, 283-292.
- Nei, M. 1987 *Molecular Evolutionary Genetics*. New York: Columbia University Press.
- Nishida, T. 1987 Local traditions and cultural transmission. In *Primate Societies* (Smuts, B.B., Cheney, D.L., Seyfarth, R.M., Wrangham, R.W. & Struhsaker, T.T.) pp.462-474. Chicago: University of Chicago Press.
- Olesiuk, P.F., Bigg, M.A. & Ellis, G.M. 1990 Life history and population dynamics of resident killer whales (*Orcinus orca*) in the coastal waters of British Columbia and Washington State. *Report of the International Whaling Commission Special Issue* **12**, 209-243.
- Paetkau, D., Waits, L.P., Clarkson, P.L., Craighead, L. & Strobeck, C. 1997 An empirical evaluation of genetic distance statistics using microsatellite data from bear (Ursidae) populations. *Genetics* **147**, 1943-1957.
- Palsbøll, P.J., Larsen, F. & Hansen, E.S. 1991 Sampling of skin biopsies from free-ranging large cetaceans in West Greenland: development of new biopsy tips and bolt designs. *Report of the International Whaling Commission Special Issue* **13**, 71-79.
- Patenaude, N.J. & White, B.N. 1995 Skin biopsy sampling of beluga whale carcasses: assessment of biopsy darting factors for minimal wounding and effective sample retrieval. *Marine Mammal Science* **11**, 163-171.
- Pusey, A.E. & Packer, C. 1987 Dispersal and philopatry. In *Primate Societies* (Smuts, B.B., Cheney, D.L., Seyfarth, R.M., Wrangham, R.W. & Struhsaker, T.T.) pp.250-266. Chicago: University of Chicago Press.
- Raymond, M. & Rousset, F. 1995 GENEPOP (version 1.2): population genetics software for exact tests and ecumenicism. *Journal of Heredity* **86**, 248-249.
- Richard, K.R., Whitehead, H. & Wright, J.M. 1996 Polymorphic microsatellites from sperm whales and their use in the genetic identification of individuals from naturally sloughed pieces of skin. *Molecular Ecology* **5**, 313-315.

- Richerson, P.J. & Boyd, R. 1998 The evolution of human ultra-sociality. In *Indoctrinability, Warfare and Ideology: Evolutionary Perspectives* (Eibl-Eibesfeldt, I. & Salter, F.K.) pp.71–95. New York: Berghahn.
- Ross, P.S., Ellis, G.M., Ikonomou, M.G., Barrett-Lennard, L.G. & Addison, R.F. 2000 High PCB concentrations in free-ranging Pacific killer whales, *Orcinus orca*: effects of age, sex and dietary preference. *Marine Pollution Bulletin* **40**, 504–515.
- Saitou, N. & Nei, M. 1987 The neighbor-joining method: A new method for reconstructing phylogenetic trees. *Molecular Biology and Evolution* **4**, 406–425.
- Sambrook, J., Fritsch, E.F. & Maniatis, T. 1989 *Molecular cloning: a laboratory manual*. 3rd ed. NY: Cold Spring Harbor.
- Saulitis, E.L. 1993 The behavior and vocalizations of the "AT" group of killer whales (*Orcinus orca*) in Prince William Sound, Alaska. M.Sc. thesis, University of Alaska, Fairbanks.
- Saulitis, E., Matkin, C., Barrett-Lennard, L., Heise, K., & Ellis, G. 2000 Foraging strategies of killer whale populations in Prince William Sound, Alaska. *Marine Mammal Science* **16**, 94-109.
- Schlötterer, C., Amos, B. & Tautz, D. 1991 Conservation of polymorphic simple sequence loci in cetacean species. *Nature* **354**, 63–65.
- Simpson, C.G. 1961 *Principles of Animal Taxonomy. The Species and Lower Categories*. New York: Columbia University Press.
- Smuts, B.B. & Smuts, R.W. 1993 Male aggression and sexual coercion of females in non-human primates and other mammals: evidence and theoretical implications. *Advances in the Study of Behavior* **22**, 1–63.
- Southern, S.O., Southern, P.J. & Dizon, A.E. 1988 Molecular characterization of a cloned mitochondrial genome. *Journal of Molecular Ecology* **28**, 32–42.
- Stevens, T.A., Duffield, D.A., Asper, E.D., Hewlett, K.G., Bolz, A., Gage, L.J. & Bossart, G.D. 1989 Preliminary findings of restriction fragment differences in mitochondrial DNA among killer whales (*Orcinus orca*). *Canadian Journal of Zoology* **67**, 2592–2595.
- Storz, J.F. 1999 Genetic consequences of mammalian social structure. *Journal of Mammalogy* **80**, 553–569.
- Sugg, D.W., Chesser, R.K., Dobson, F.S. & Hoogland, J.L. 1996 Population genetics meets behavioral ecology. *Trends in Ecology and Evolution* **11**, 338–342.
- Swofford, D.L. 1998 PAUP\* Phylogenetic Analysis Using Parsimony (\*and Other Methods). Version 4. Sunderland, Massachusetts: Sinauer Associates.

- Swofford, D.L., Olsen, G.J., Waddell, P.J. & Hillis, D.M. 1996 Phylogenetic inference. In *Molecular Systematics* (Hillis, D.M., Moritz, C. & Mable, B.K.), 2nd ed. pp.407–514. Sunderland, Massachusetts: Sinauer Associates, Inc.
- Thompson, J.D., Higgins, D.G. & Gibson, J. 1994 CLUSTAL W: improving the sensitivity of progressive multiple sequence alignment through sequence weighting, position-specific gap penalties and weight matrix choice. *Nucleic Acids Research* **22**, 4673–4680.
- Trexler, J.C. & Travis, J. 1993 Nontraditional regression analyses. *Ecology* **74**, 1629–1637.
- Trivers, R.L. 1971 The evolution of reciprocal altruism. *Quarterly Review of Biology* **46**, 35–57.
- Valsecchi, E. & Amos, W. 1996 Microsatellite markers for the study of cetacean populations. *Molecular Ecology* **5**, 151–156.
- Waite, J.M. 1988 Alloparental care in killer whales (*Orcinus orca*). M.Sc. Thesis, University of California, Santa Cruz.
- Walker, L.A., Cornell, L., Dahl, K.D., Czekala, N.M., Dargen, C.M., Joseph, B., Hsueh, A.J.W. & Lasley, B.L. 1988 Urinary concentrations of ovarian steroid hormone metabolites and bioactive follicle-stimulating hormone in killer whales (*Orcinus orca*) during ovarian cycles and pregnancy. *Biology of Reproduction* **39**, 1013–1020.
- Walters, J.R. & Seyfarth, R.M. 1986 Conflict and cooperation. In *Primate Societies* (Smuts, B.B., Cheney, D.L., Seyfarth, R.M., Wrangham, R.W. & Struhsaker, T.T.) pp.306–317. Chicago: University of Chicago Press.
- Weinrich, M.T., Lambertsen, R.H., Baker, C.S., Schilling, M.R. & Belt, C.R. 1991 Behavioural responses of humpback whales (*Megaptera novaeangliae*) in the southern Gulf of Maine to Biopsy Sampling. *Report of the International Whaling Commission Special Issue* **13**, 91–97.
- Weinrich, M.T., Lambertson, R.H., Belt, C.R., Schilling, M.R., Iken, H.J. & Syrjala, S.E. 1992 Behavioural reactions of humpback whales *Megaptera novaeangliae* to biopsy procedures. *Fishery Bulletin* **90**, 588–598.
- Weir, B.S. 1996 *Genetic Data Analysis II*. Sunderland, Massachusetts: Sinauer.
- Weir, B.S. & Cockerham, C.C. 1984 Estimating *F*-statistics for the analysis of population structure. *Evolution* **38**, 1358–1370.
- Whitehead, H. 1993 The behaviour of mature male sperm whales on the Galapagos Islands breeding grounds. *Canadian Journal of Zoology* **71**, 689–699.
- Whitehead, H. 1998 Cultural selection and genetic diversity in matrilineal whales. *Science* **282**, 1708–1711.

- Whitehead H., Gordon, J., Mathews, E.A. & Richard, K.R. 1990 Obtaining skin samples from living sperm whales. *Marine Mammal Science* **6**, 316-326.
- Whiten, A., Goodall, J., McGrew, W.C., Nishida, T., Reynolds, V., Sugiyama, Y., Tutin, C.E.G., Wrangham, R.W. & Boesch, C. 1999 Cultures in Chimpanzees. *Nature* **399**, 682-685.
- Whitlock, M.C. & McCauley, D.E. 1990 Some population genetic consequences of colony formation and extinction: genetic correlations within founding groups. *Evolution* **44**, 1717-1724.
- Williams-Blangero, S. 1990 Population structure of the Jirels: patterns of mate choice. *American Journal of Physical Anthropology* **82**, 61-71.
- Wilson, E.O. 1971 *The Insect Societies*. Cambridge, Massachusetts: University of Harvard Press.
- Winn, H.E., Bischoff, W.L. & Taruski, A.G. 1973 Cytological sexing of cetacea. *Marine Biology* **23**, 343-346.
- Wright, S. 1951 The genetical structure of populations. *Annals of Eugenics* **15**, 323-354.
- Yengoyan, A.A. 1968 Demographic and ecological influences on Aboriginal Australian marriage systems. In *Man the Hunter* (Lee, R.B. & DeVore, I.) pp.185-199. Chicago: Aldine.
- Yurk, H., Barrett-Lennard, L.G., Ford, J.K.B. & Matkin, C.O. in prep. Parallel cultural and genetic lineages in resident killer whales off the coast of Southern Alaska.
- Zar, J.H. 1996 *Biostatistical Analysis*. 3rd ed. Upper Saddle River, New Jersey: Prentice Hall Inc.

## APPENDIX 1

Mitochondrial D-loop sequences for resident, transient and offshore killer whales and for killer whales captured near Iceland.

	10	20	30	40	50	60
NR	CTGGAATTCT	ACATAAACTA	TTCCTTGGAA	AAAGCTTATT	GTACAATTAC	TATAACATCA
SR	.....	.....	.....	.....	.....	.....
WCT	.....	.....	.....	.....	.....	.....
GAT1	.....	.....	.....	.....	.....	.....
GAT2	.....	.....	.....	.....	.....	.....
AT1	.....	.....	.....	.....	.....	.....
OFF	.....	.....	.....	.....	.....	.....
ICE	.....	.....	.....	.....	.....	.....
					6	
NR	70	80	90	100	110	120
NR	CAGTACTACC	CTAGTATTAA	AAGTAACTGT	TTTAAAAACA	TTCCACTGTA	CACACCACAT
SR	.....	.....	.....	.....	.....	.....
WCT	.....	.....	.....	.....	.....	.....
GAT	.....	.....	.....	.....	.....	.....
GAT2	.....	.....	.....	.....	.....	.....
AT1	.....	.....	.....	.....	.....	.....
OFF	.....	.....	.....	.....	.....	.....
ICE	.....	.....	.....	.....	.....C.....	.....
					2	
NR	130	140	150	160	170	180
NR	ACACACATAC	ACATACATAT	TAATATTCTA	GTCTTCTCTT	TATAATATTC	GTATATACAT
SR	.....	.....	.....	.....	.....	.....
WCT	.....	.....	.....	.....	.....	.....A.....
GAT	.....	.....	.....	.....	.....	.....
GAT2	.....	.....	.....	.....	.....	.....
AT1	.....	.....	.....	.....	.....	.....
OFF	.....	.....	.....	.....	.....	.....
ICE	.....	.....	.....	.....	.....	.....
NR	190	200	210	220	230	240
NR	GCTATGTATT	ATTGTGCATT	CATTTATTTT	CCATACGATA	AGTTAAAGCC	CGTATTAATT
SR	.....	.....	.....	.....	.....	.....
WCT	.....	.....	.....	.....	.....	.....
GAT2	.....	.....	.....	.....	.....	.....
GAT	.....	.....	.....	.....	.....	.....
AT1	.....	.....	.....	.....	.....	.....
OFF	.....	.....	.....	.....	.....	.....
ICE	.....	.....	.....	.....	.....	.....
NR	250	260	270	280	290	300
NR	ATCATTAAATT	TTACATATTA	CATAATTTGC	ATGCTCTTAC	ATATTATATG	TCCCCTAATA
SR	.....	.....	.....	.....	.....	.....
WCT	.....	.....	.....	.....	.....	.....
GAT	.....	.....	.....	.....	.....	.....
GAT2	.....	.....	.....	.....	.....	.....
AT1	.....	.....	.....	.....	.....	.....
OFF	.....	.....	.....	.....	.....	.....
ICE	.....	.....	.....	.....	.....	.....

...cont.

			<b>3</b>			
	310	320	330	340	350	360
NR	TTTTTACTTC	CATTATATCC	TATGGTCACT	CCATTAGATC	ACGAGCTTAA	TCACCATGCC
SR	.....	.....	.....	.....	.....	.....
WCT	.....	.....	.....	.....	.....	.....
GAT	.....	.....	.....	.....	.....	.....
GAT2	.....	.....	.....	.....	.....	.....
AT1	.....	.....	G	.....	.....	.....
OFF	.....	.....	.....	.....	.....	.....
ICE	.....	.....	T	.....	.....	.....

					<b>4</b>	
	370	380	390	400	410	420
NR	GCGTGAAACC	AGCAACCCGC	TTGGCAGGGA	TCCCTCTTCT	CGCACCGGGC	CCATATCTCG
SR	.....	.....	.....	.....	.....	.....
WCT	.....	.....	.....	.....	.....	C
GAT	.....	.....	.....	.....	.....	C
GAT2	.....	.....	.....	.....	.....	.....
AT1	.....	.....	.....	.....	.....	C
OFF	.....	.....	.....	.....	.....	.....
ICE	.....	.....	.....	.....	.....	.....

		<b>5</b>				
	430	440	450	460	470	480
NR	TGGGGGTAGC	TAATAATGAT	CTTTATAAGA	CATCTGGTTC	TTACTTCAGG	ACCATTTTAA
SR	.....	.....	.....	.....	.....	.....
WCT	.....	G	.....	.....	.....	.....
GAT1	.....	G	.....	.....	.....	.....
GAT2	.....	G	.....	.....	.....	.....
AT1	.....	.....	.....	.....	.....	.....
OFF	.....	.....	.....	.....	.....	.....
ICE	.....	.....	.....	.....	.....	.....

	<b>12</b>				<b>7 8</b>	
	490	500	510	520	530	540
NR	TCTAAAATCG	CCCACCTCGTT	CCCCTTAAAT	AAGACATCTC	GATGGACTTA	TGACTAATCA
SR	.....	.....	.....	.....	C	.....
WCT	T	.....	.....	.....	T.C	.....
GAT1	T	.....	.....	.....	T.C	.....
GAT2	T	.....	.....	.....	T.C	.....
AT1	T	.....	.....	.....	T.C	.....
OFF	.....	.....	.....	.....	C	.....
ICE	.....	.....	.....	.....	C	.....

			<b>9</b>			
	550	560	570	580	590	600
NR	GCCCATGCCT	AACATAACTG	AGATTTCATA	CATTTGGTAT	TTTTTAATT	TTGGGGGGGA
SR	.....	.....	.....	.....	.....	.....
WCT	.....	.....	C	.....	.....	.....
GAT	.....	.....	C	.....	.....	.....
GAT2	.....	.....	C	.....	.....	.....
AT1	.....	.....	C	.....	.....	.....
OFF	.....	.....	.....	.....	.....	.....
ICE	.....	.....	.....	.....	.....	.....

...cont.

	610	620	630	640	10 650	660
NR	GCTTGCACCG	ACTCAGCTAT	GGCCTTAGAA	AGGCCCCGTC	ACAGTCAAAT	AAATTGTAGC
SR	.....	.....	.....	.....	.....	.....
WCT	.....	.....	.....	.....	.....	.....
GAT	.....	.....	.....	.....	.....	.....
GAT2	.....	.....	.....	.....	.....	.....
AT1	.....	.....	.....	.....	.....	.....
OFF	.....	.....	.....	.....	C	.....
ICE	.....	.....	.....	.....	.....	.....

	670	680	690	700	710	720
NR	TGGACCTGTG	TGTATTTTGT	ATTGGACTAG	CACAACCAAC	AGGTGTTATT	TAATTAATGG
SR	.....	.....	.....	.....	.....	.....
WCT	.....	.....	.....	.....	.....	.....
GAT	.....	.....	.....	.....	.....	.....
GAT2	.....	.....	.....	.....	.....	.....
AT1	.....	.....	.....	.....	.....	.....
OFF	.....	.....	.....	.....	.....	.....
ICE	.....	.....	.....	.....	.....	.....

	730	740	750	760	770	780
NR	TTACAGGACA	TAGTACTCCA	TATTCCCCCC	GGGCTCAAAA	AACCCTATCT	CATAGAGGTT
SR	.....	.....	.....	.....	.....	.....
WCT	.....	.....	.....	.....	.....	.....
GAT	.....	.....	.....	.....	.....	.....
GAT2	.....	.....	.....	.....	.....	.....
AT1	.....	.....	.....	.....	.....	.....
OFF	.....	.....	.....	.....	.....	.....
ICE	.....	.....	.....	.....	.....	.....

	790	800	810	11 820	830	840
NR	TAACCCCCCT	TCCCCCTTAC	AAAACCTAATC	GTCTGCTTTA	ATATTCACCA	TCCCCCTACA
SR	.....	.....	.....	.....	.....	.....
WCT	.....	.....	.....	G	.....	.....
GAT1	.....	.....	.....	G	.....	.....
GAT2	.....	.....	.....	G	.....	.....
AT1	.....	.....	.....	G	.....	.....
OFF	.....	.....	.....	.....	.....	.....
ICE	.....	.....	.....	.....	.....	.....

	850	860	870	880	890	900
NR	GTGCTTCGTC	CCTAGATCTA	CGCGCATTTT	TTTTTATAAA	TCAATACTAA	ATCTGACACA
SR	.....	.....	.....	.....	.....	.....
WCT	.....	.....	.....	.....	.....	.....
GAT1	.....	.....	.....	.....	.....	.....
GAT2	.....	.....	.....	.....	.....	.....
AT1	.....	.....	.....	.....	.....	.....
OFF	.....	.....	.....	.....	.....	.....
ICE	.....	.....	.....	.....	.....	.....

...cont.



	<b>910</b>	<b>920</b>	<b>930</b>	<b>940</b>	<b>950</b>
NR	AGCCCCATAA	TGAAATTATA	CAAATAATTT	TCTGCCCCCC	TCCCCCGTTG
SR	.....	.....	.....	.....	.....
WCT	.....	.....	.....	.....	.....
GAT1	.....	.....	.....	.....	.....
GAT2	.....	.....	.....	.....	.....
AT1	.....	.....	.....	.....	.....
OFF	.....	.....	.....	.....	.....
ICE	.....	.....	.....	.....	.....

The D-loop extends from nucleotide positions 28 to 946, inclusive (a total of 919 bases). Parts of tRNA-pro and tRNA-phe are shown at the beginning and end of this sequence, respectively. Variable sites are assigned the numbers in bold font above them. Variable sites 1,6,10 and 11 were identified for the first time in this study, while the remaining variable sites were also identified by Hoelzel et al. (1998). The northern residents, southern residents, AT1 transients, offshores, and two whales captured near Iceland were each monomorphic for single unique haplotypes, designated NR, SR, AT1, OFF, and ICE, respectively. The Gulf of Alaska transients had two haplotypes, designated GAT1 and GAT2. The two acoustic clans of the southern Alaskan residents, AB-clan and AD-clan, had NR and SR haplotypes, respectively.

## APPENDIX 2

Distribution of alleles at 11 microsatellite loci in seven subpopulations<sup>1</sup> of killer whales from Alaska and British Columbia.

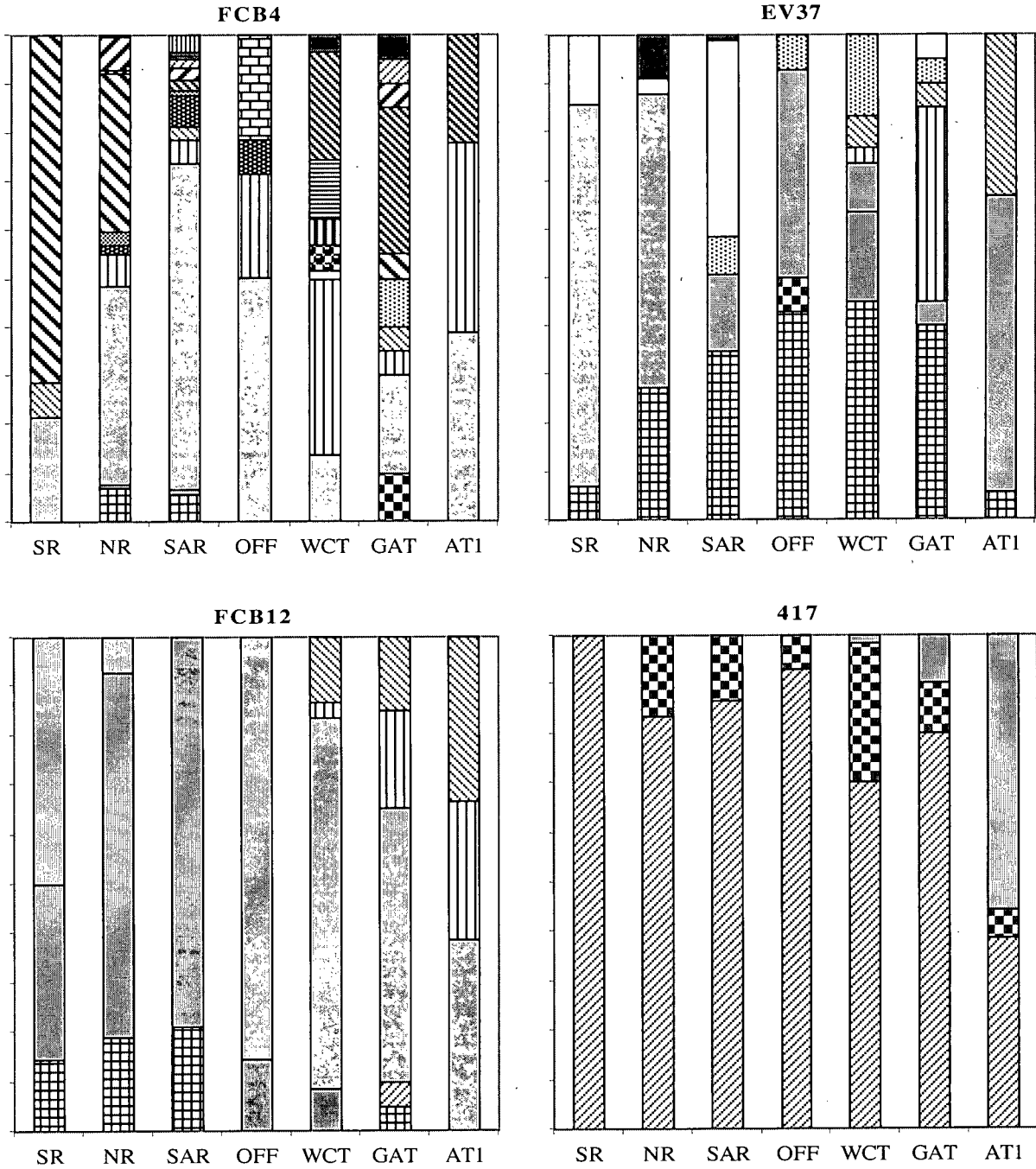

...cont.

KWM2

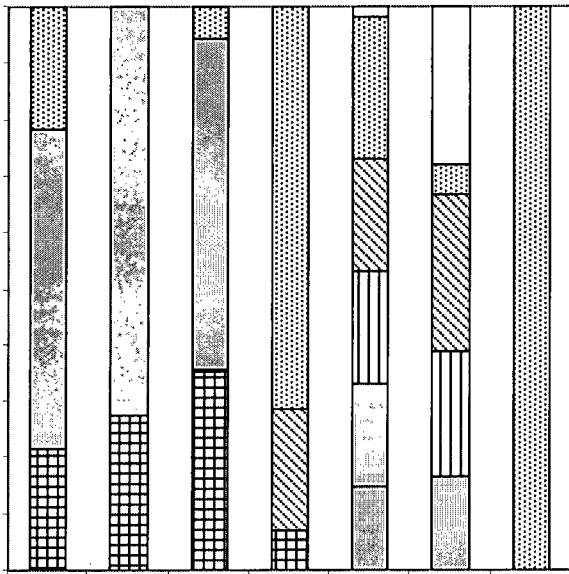

SR NR SAR OFF WCT GAT AT1

FCB17

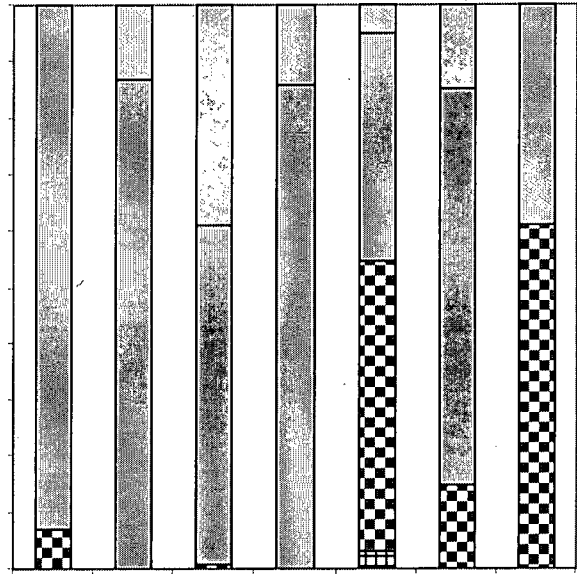

SR NR SAR OFF WCT GAT AT1

FCB5

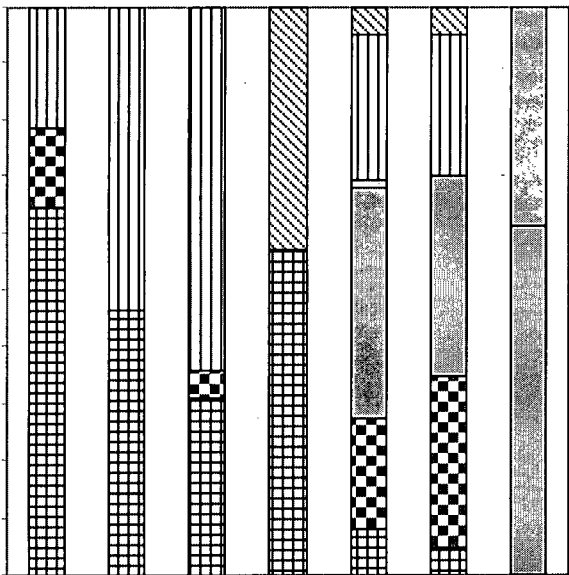

SR NR SAR OFF WCT GAT AT1

EVI

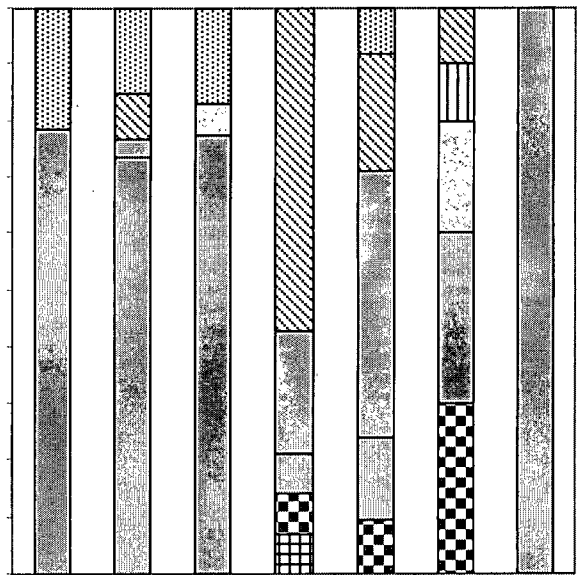

SR NR SAR OFF WCT GAT AT1

...cont.

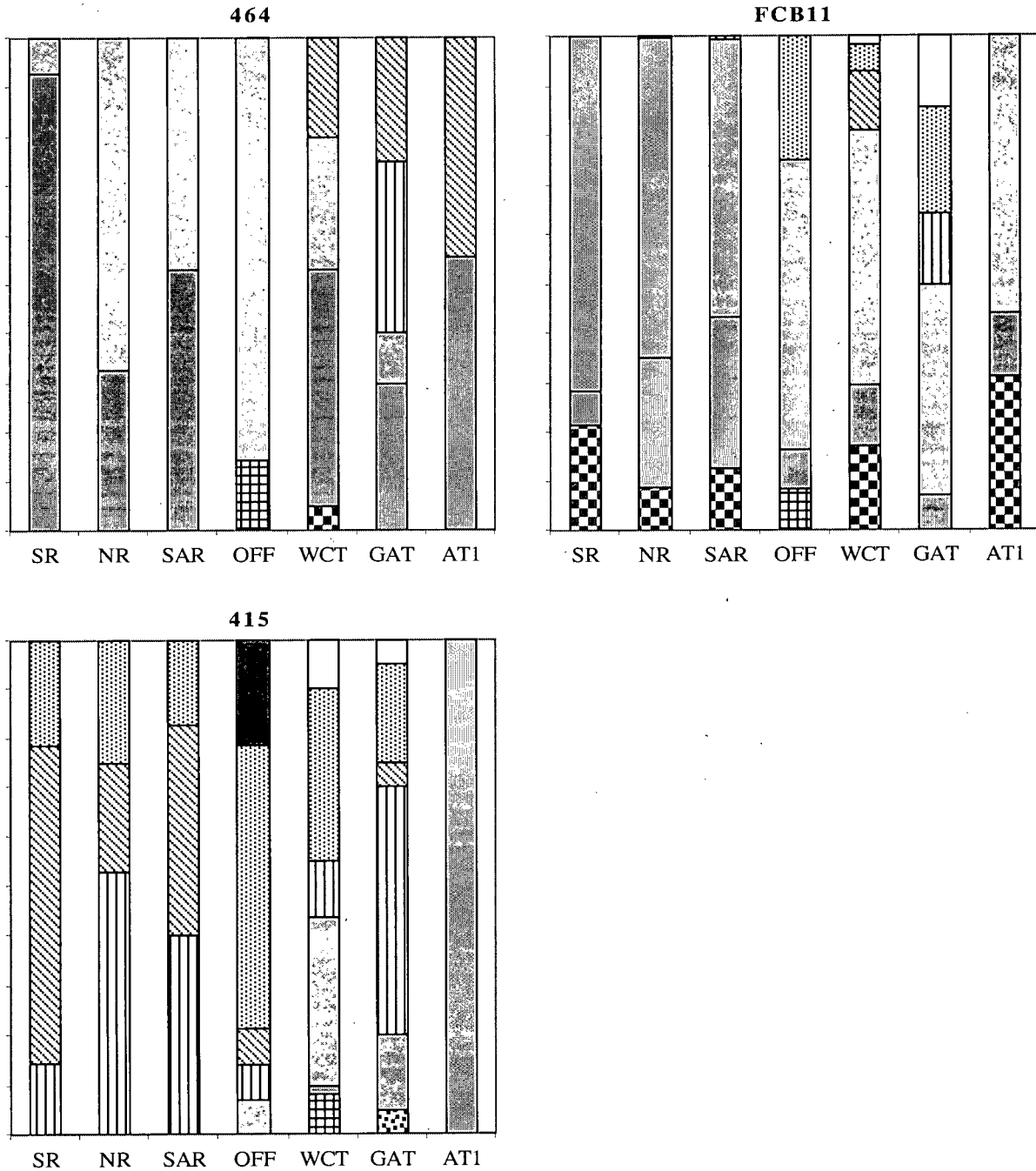

Each graph depicts the allele frequency distributions at a single locus for each of seven subpopulations. The alleles at a given locus are shaded differently and their frequency is proportional to the length of their segments. The subpopulation names are abbreviated as follows: southern residents, SR; northern residents, NR; southern Alaskan residents, SAR; offshores, OFF; west coast transients, WCT; Gulf of Alaska transients, GAT; AT1 transients, AT1. Locus names beginning with "FCB", "EV", "4", and "KW" are described in Buchanan et al. (1996), Valsecchi and Amos (1996), Schlotterer et al. (1991) and Hoelzel et al. (1998), respectively.

<sup>1</sup>The offshore population is treated as a subpopulation in this figure.