

CECW-ED Engineer Manual 1110-2-2705	Department of the Army U.S. Army Corps of Engineers Washington, DC 20314-1000	EM 1110-2-2705 31 March 1994
	Engineering and Design STRUCTURAL DESIGN OF CLOSURE STRUCTURES FOR LOCAL FLOOD PROTECTION PROJECTS	
	Distribution Restriction Statement Approved for public release; distribution is unlimited.	

DEPARTMENT OF THE ARMY
U.S. Army Corps of Engineers
Washington, DC 20314-1000

EM 1110-2-2705

CECW-ED

Manual
No. 1110-2-2705

31 March 1994

Engineering and Design
STRUCTURAL DESIGN OF CLOSURE STRUCTURES
FOR LOCAL FLOOD PROTECTION PROJECTS

1. Purpose. This engineer manual (EM) provides guidance for the structural design of closure structures for openings in levees and floodwalls of inland local flood protection projects (LFPPs). Design requirements for aluminum and steel stoplog closure structures and steel swing, miter, trolley, and rolling gate closure structures for openings in levees and floodwalls of LFPPs are addressed. This guidance provides a framework for incorporating the required elements of design execution into the design process for closure structures.

2. Applicability. This manual is applicable to all HQUSACE elements, major subordinate commands, districts, laboratories and field operating activities having civil works design and construction responsibilities.

FOR THE COMMANDER:



WILLIAM D. BROWN
Colonel, Corps of Engineers
Chief of Staff

20020628 032

CECW-ED

Manual
 No. 1110-2-2705

31 March 1994

Engineering and Design
**STRUCTURAL DESIGN OF CLOSURE STRUCTURES
 FOR LOCAL FLOOD PROTECTION PROJECTS**

Table of Contents

Subject	Paragraph	Page	Subject	Paragraph	Page
Chapter 1			Chapter 6		
Introduction			Corrosion Protection		
Purpose and Scope	1-1	1-1	Criteria	6-1	6-1
Applicability	1-2	1-1			
References	1-3	1-1	Appendix A		
Background	1-4	1-1	Checklist for Structural Design of Closure Structures		
Chapter 2			Appendix B		
Design			Stoplog Design Examples		
Design Process	2-1	2-1	Appendix C		
Design Coordination	2-2	2-1	Swing Gate Design Example		
General Design Provisions	2-3	2-1	Appendix D		
Chapter 3			Miter Gate Design Example		
Selection of Closure Types			Appendix E		
Facilities Requiring Closures	3-1	3-1	Rolling Gate Design Example		
Closure Structure Types	3-2	3-1	Appendix F		
Chapter 4			Trolley Gate Design Example		
Structural Analyses and Design					
Stress Criteria	4-1	4-1			
Loading Criteria	4-2	4-1			
Design Analysis Criteria	4-3	4-1			
Chapter 5					
Appurtenant Components					
Gate Operating Equipment	5-1	5-1			
Seal Assemblies	5-2	5-1			
Embedded Metals	5-3	5-1			

Chapter 1 Introduction

1-1. Purpose and Scope

a. Purpose. This engineer manual (EM) provides guidance for the structural design of closure structures for openings in levees and floodwalls of inland local flood protection projects (LFPPs).

b. Scope. The scope of this guidance includes the design requirements for aluminum and steel stoplog closure structures and steel swing, miter, trolley, and rolling gate closure structures for openings in levees and floodwalls of LFPPs. This guidance provides a framework for incorporating the required elements of design execution into the design process for closure structures.

1-2. Applicability

This manual is applicable to all HQUSACE elements, major subordinate commands, districts, laboratories, and field operating activities having civil works design and construction responsibilities.

1-3. References

a. EM 1110-2-38, Environmental Quality in Design of Civil Works Projects.

b. EM 1110-2-301, Guidelines for Landscape Planting at Flood Walls, Levees, and Embankment Dams.

c. EM 1110-2-2104, Strength Design for Reinforced-Concrete Hydraulic Structures.

d. EM 1110-2-2105, Design of Hydraulic Steel Structures.

e. EM 1110-2-2502, Retaining and Flood Walls.

f. EM 1110-2-2703, Lock Gates and Operating Equipment.

g. EM 1110-2-2906, Design of Pile Foundations.

h. EM 1110-2-3104, Structural and Architectural Design of Pumping Stations.

i. EM 1110-2-3400, Painting: New Construction and Maintenance.

j. Aluminum Association, Inc. 1986. "Specifications for Aluminum Structures," 900 19th Street, NW, Suite 300, Washington, DC 20006.

k. American Association of State Highway and Transportation Officials (AASHTO). 1989. "Standard Specifications for Highway Bridges," 14th ed., 444 North Capitol Street, NW, Suite 225, Washington, DC 20001.

l. American Institute of Steel Construction (AISC). 1986. "Manual of Steel Construction, Load and Resistance Factor Design (LRFD)," 1st ed., 400 North Michigan Avenue, Chicago, IL 60611.

m. American Institute of Steel Construction (AISC). 1989. "Manual of Steel Construction, Allowable Stress Design (ASD)," 9th ed., 400 North Michigan Avenue, Chicago, IL 60611.

n. American Railway Engineering Association. 1991. "1991 Manual for Railway Engineering," Volume I, Chapters 1 through 8, and Volume II, Chapters 9 through 33, 50 F Street, NW, Suite 7702, Washington, DC 20001.

1-4. Background

This manual was developed to provide uniform criteria for the design of closure structures for openings in levees and floodwalls of LFPPs. The development process involved reviewing and evaluating the design and performance of existing closure structures constructed throughout the Corps to identify the structures which are cost-effective and efficient in operation, and incorporating the design features of these projects into the criteria provided herein. The resulting guidance contained in this manual provides a series of design requirements and provisions that should be applied to the design of closure structures.

Chapter 2 Design

2-1. Design Process

The structural design of closure structures for openings in levees and floodwalls should be planned in detail to ensure that the elements of the structural design responsibility are properly executed during the reconnaissance phase through the operations phase of projects. These elements include: coordinating the required input from the project manager, project engineer, and other engineering disciplines and functional members of the design team; incorporating general design provisions into the design process and resulting solutions which pertain to operational, functional, maintenance, aesthetics, safety, security, construction, and economical considerations; examining and comparing pertinent features of closure types, selecting the appropriate closures and suitable alternatives for particular applications, and defining the preferred general design concept which provides a basis for estimating the construction cost; and performing the required structural analyses and design of structural features and ensuring design quality through design review and other methods of verification. Appendix A provides a checklist of design functions required during each phase of the design process.

2-2. Design Coordination

Full coordination of the total design process should be considered as the most essential element for ensuring design quality. The structural engineer must operate within the prescribed role and functional relationships established between the structural discipline and the project manager, project engineer, engineering disciplines, and other functional elements engaged in the design process to effectuate the coordination required for the design of closures.

a. Project manager. Throughout the design process, the project manager is responsible for coordinating with the local sponsor, communicating input from the local interests to the project engineer and design engineers, and ensuring that the major design features of closure structures are acceptable to the local interests. The project manager must also obtain agreement with agencies or entities which own and maintain utilities and facilities which would be impacted by the construction of the closure structures. Such facilities include pipe lines, transmission lines, streets, highways, bridges, and railroads.

b. Project engineer. The project engineer, in managing the design of closure structures, is responsible for interacting with the project manager to obtain the agreed local sponsor requirements and acceptance of proposed design solutions for closure structures and communicating these to the functional elements engaged in the project including real estate, planning, engineering, construction, and operations.

c. Structural engineer. The structural engineer is responsible for coordinating with the project engineer and other engineering disciplines engaged in the design of closure structures, including civil, geotechnical, hydraulic, mechanical, coastal, environmental, construction, and operations engineers, to ensure all pertinent engineering considerations are properly integrated into the structural design.

2-3. General Design Provisions

General design provisions which must be integrated into the design process for the design and construction of closure structures for LFPP include operational, functional, maintenance, aesthetics, safety, security, construction, and economical considerations. These provisions must be fully and appropriately addressed in the design process and the resulting project documents.

a. Operational. The required lead time for closing the structures in the event of flooding is controlled by the rate of rise of the flood waters. The accuracy of advanced forecasting of flooding determines the length of time which should be scheduled for the mobilization of operations personnel and equipment required to close the structures. Also, the accuracy of forecasting determines the number of times traffic is inconvenienced by a closed structure when flooding does not occur. The scheduled time for closure of structures should include a cushion to ensure that closure is completed well before the arrival of flood waters. The required lead time and the types of operating equipment and operations personnel available to the local sponsor are the primary factors in determining the type of closure structures suitable for particular applications.

b. Functional. Functional requirements for facilities, such as roadways and railroads, affect the design of closure structures. Existing site topography and clearance requirements for roadways (highways and streets) and railroads are primary functional considerations which must be incorporated into the design of closure structures.

(1) Site topography. Existing grades parallel to roadways and railroads affect the required site distances along these facilities. Variation of grades along roadways and railroads affects the selection of the type of closure structures and the design of sills and supports for these facilities. For example, multiple sets of railroad tracks occurring at different grade elevations require a hinged bottom seal arrangement to provide an effective seal.

(2) Clearances.

(a) Roadways. The opening widths provided for roadways shall comply with the requirements of the American Association of State Highway and Transportation Officials (AASHTO) (1989). The width of closure openings should not be less than 30 ft for roadways with two lanes of traffic. The minimum vertical clearance between the crown of roadways and fixed overhead components of closures should not be less than 14 ft. Clearances should be coordinated and approved by the facility owner.

(b) Railroads. Minimum horizontal and vertical clearances shall not be less than that required by the AASHTO (1989). The normal minimum width of opening provided for railroads is approximately 20 ft for each set of tracks involved in the closure. Clearances should be coordinated with and approved by the facility owner.

c. Maintenance. Proper maintenance of closure structures is essential to the continuous satisfactory performance of the structures. The required maintenance provisions must be included in the agreement with the local sponsor. Current agreements with local sponsors require annual periodic inspections of the closure structures and the adjoining levee or floodwall. Inspections must be thorough so that any deficiencies that are critical to the function of the project are detected and promptly corrected. Designs should incorporate materials, systems, and features which are economically feasible and require minimal maintenance.

d. Aesthetics. The requirements for incorporating aesthetic quality into the design of LFPP have been established. EM 1110-2-38 provides guidance for aligning flood control channels, landscaping along channels, and the aesthetic treatment of channel linings. EM 1110-2-301 also provides guidance for landscaping. In some LFPP floodwalls, an open view of the waterway was made an aesthetic requirement. These projects incorporate closures with bottom hinged walls which can be

stored in the lowered position and raised for protection during flood periods.

e. Safety. The design of closures must include safety provisions for the public and the operations personnel. Local sponsors are responsible for the safe operation of closure structures; therefore, designers must coordinate with sponsors so that the appropriate design provisions are incorporated to ensure safe operation. General safety provisions include providing railings on the top of gates and adjacent walls for public protection and providing ladders for access by operations personnel. Additional safety features could include warning signs and barriers which prevent access by unauthorized persons.

f. Security. The design of closure structures must include security provisions which prevent vandalism and the impairment of operating capability. Locked storage facilities which are inaccessible to the public should be provided for the storage of stoplogs, removable posts, and other unsecured parts of closure structures. In areas subject to vandalism, masonry buildings should be used. Latching devices which hold gates in the stored position should be provided with adequate locks.

g. Construction.

(1) Procedures and methods. Construction procedures and methods should be considered during design to facilitate the general constructibility of closure structures. All phases of construction and erection procedures, particularly for gated closure structures, should be considered and design details developed which minimize complexities.

(2) Assurance of design integrity. The structural designer must identify, in the project documents, the design assumptions, details, and specifications essential to design integrity. This is necessary to make certain that the closure features receive assurance inspection during construction to verify that actual construction methods are in compliance with the design assumptions, details, and specifications.

h. Cost comparisons. The costs of previously constructed closure structures vary according to the closure type and opening size. These variations should be considered in making cost-effective decisions in the selection of the closure type and the design of closure structures for openings in levees and floodwalls of LFPPs.

Chapter 3 Selection of Closure Types

3-1. Facilities Requiring Closures

Closure structures are required at openings in levee and floodwall systems when facilities such as railroads, roadways, and pedestrian walkways pass through levee and floodwall systems at elevations below the level of protection provided by the project. The widths of openings for these facilities vary depending upon their functional purpose. Openings for railroads and roadways vary from moderate widths (20 to 40 ft) to widths of 100 ft or more. Openings for pedestrian walkways are usually 20 ft or less. The need for closures should be avoided when possible by using ramps or pedestrian overpasses.

3-2. Closure Structure Types

Closure structures for openings in levee and floodwall systems of LFPPs are usually either stoplog or gate type closures. Stoplog closure structures are usually the least

expensive. Gate closure structures are more functional because they can usually be closed and opened quickly and with less effort.

a. Stoplog closure structures. Stoplog closure structures usually consist of one or more sets of horizontal aluminum or steel beams, stacked vertically in the closed position. Aluminum stoplogs weigh less than steel stoplogs of the same size but do not have the same strength. For narrow openings, one set of beams or logs may span between support slots constructed at the edge of openings. For wider openings, intermediate, removable support posts are required as shown in Figure 3-1. Seals are not normally attached to the stoplogs; however, plastic sheeting, sandbags, or other available means should be used to reduce leakage through the stoplog closure structure. Storage facilities must be provided for the stoplogs, removable posts, and accessories. When secured areas are available, closure items may be stored on uncovered storage concrete pedestals or slabs; otherwise, a storage building must be provided. Typical details of a stoplog closure structure are shown in Plates 1-2. Advantages and disadvantages of stoplog closure structures are given below.

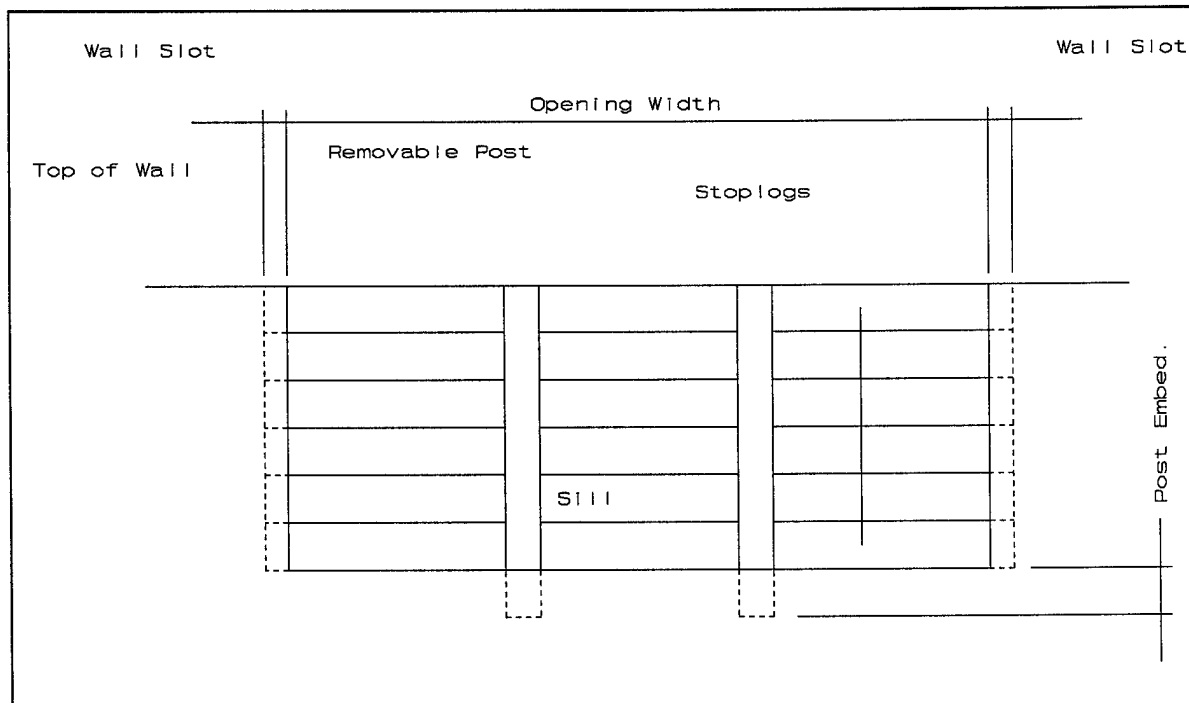

Figure 3-1. Stoplog closure structure

Advantages:

- Fabrication methods are simple and economical.
- Initial cost is usually less than for gate closures.
- Is easily operated for narrow and low openings.

Disadvantages:

- Intermediate support posts or wide stoplogs are required for wide openings which usually require special lifting equipment for installation.
- Accurate long-range weather forecasting is needed since a relatively long lead time is required to mobilize personnel and equipment for installation.

- Installation time is usually increased to allow cleaning of the post sockets during installation.

- Installation time is longer than required to close gated closures.

- A storage building is required to prevent damage by vandalism or loss by theft.

b. *Gate closure structures.* The most common type of gates used for gate closure structures are swing, miter, rolling, and trolley gates. Figure 3-2 shows outside boundary envelopes for a limited number of gate closure structures from past Corps projects. Gate types are plotted relative to the size of the closure opening. The gate sizes enclosed by the envelopes lie to the left and below the applicable curve or line. Figure 3-2 shows the type of

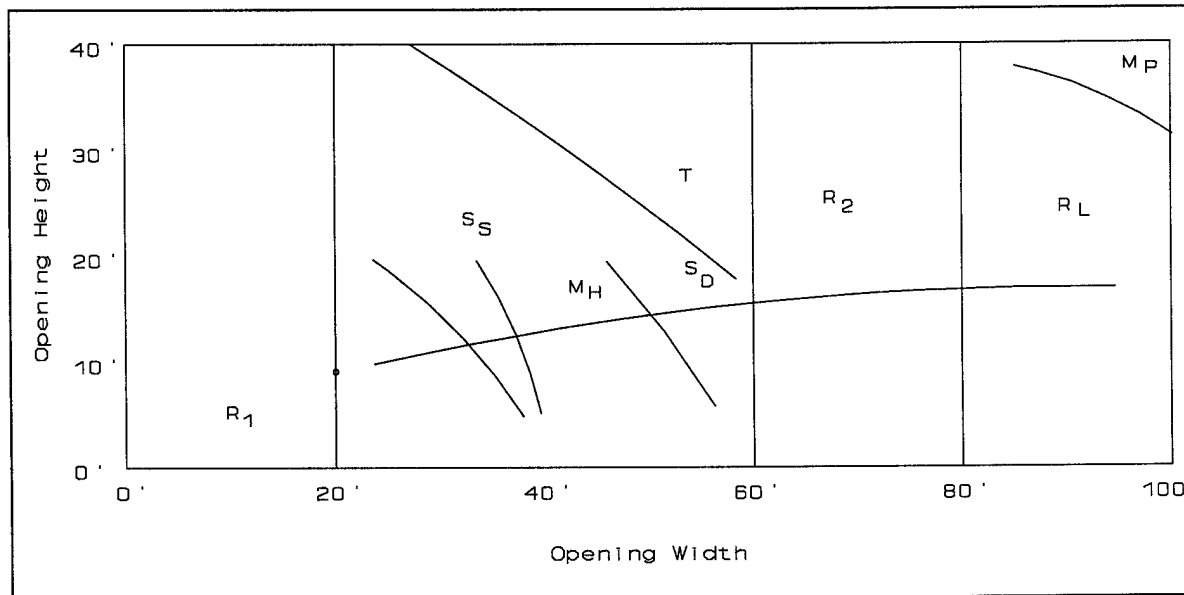

LEGEND

- S_s = Swing gate, single leaf.
- S_D = Swing gate, double leaf.
- M_H = Miter gate with hinges.
- M_P = Miter gate with pintle, continuous quoin, and miter posts.
- R_2 = Rolling gate stabilized by a double line of wheels.
- R_1 = Rolling gate with a single line of wheels, trolley stabilized.
- R_L = Rolling gate - L-frame, latch stabilized.
- T = Trolley gate.

Figure 3-2. Gate type versus opening dimensions

gate and height-to-width relationships used in past designs and is not intended to establish the maximum opening sizes for any particular gate type used in future designs.

(1) Swing gates. Swing gates are composed of two or more horizontal girders, vertical intercostals, vertical end diaphragms, a skin plate, and diagonal braces. Swing gates are supported on one side by top and bottom hinges attached to a support structure as shown in Figure 3-3. In most cases, swing gate closures consist of a single swing gate leaf. However, double leaf gates are used for wide openings. Double leaf gates must be stabilized by a removable center post or diagonal tie-back linkages as shown in Figure 3-4. One end of the diagonal linkage rods shall be permanently attached to the free ends of each gate leaf. The other end of the each linkage rod is attached to the support structure when the gates are closed. A support jack is provided beneath the gate to withstand the vertical component of load from the linkage rods. Rubber J-seals are attached to gates to form a continuous water-tight seal between the gates and supporting walls and sill of the opening. Closure provisions should include the use of winches or motor vehicles to accomplish closure during strong winds. Typical details

of a swing gate closure structure are shown in Plate 3. Typical details of hinges, seals and latches are shown in Plates 4-12. Advantages and disadvantages of swing gate closure structures are given below.

Advantages:

- Single leaf swing gates are more practical for opening widths up to 40 ft.
- Skilled personnel or equipment are not required for operation except when removable intermediate support posts are used with double leaf gates.
- A short lead time is required for making closure except when removable intermediate support posts are used with double leaf gates.

Disadvantages:

- Requires right-of-way area for operating.
- Requires complex shop fabrication with machine work.

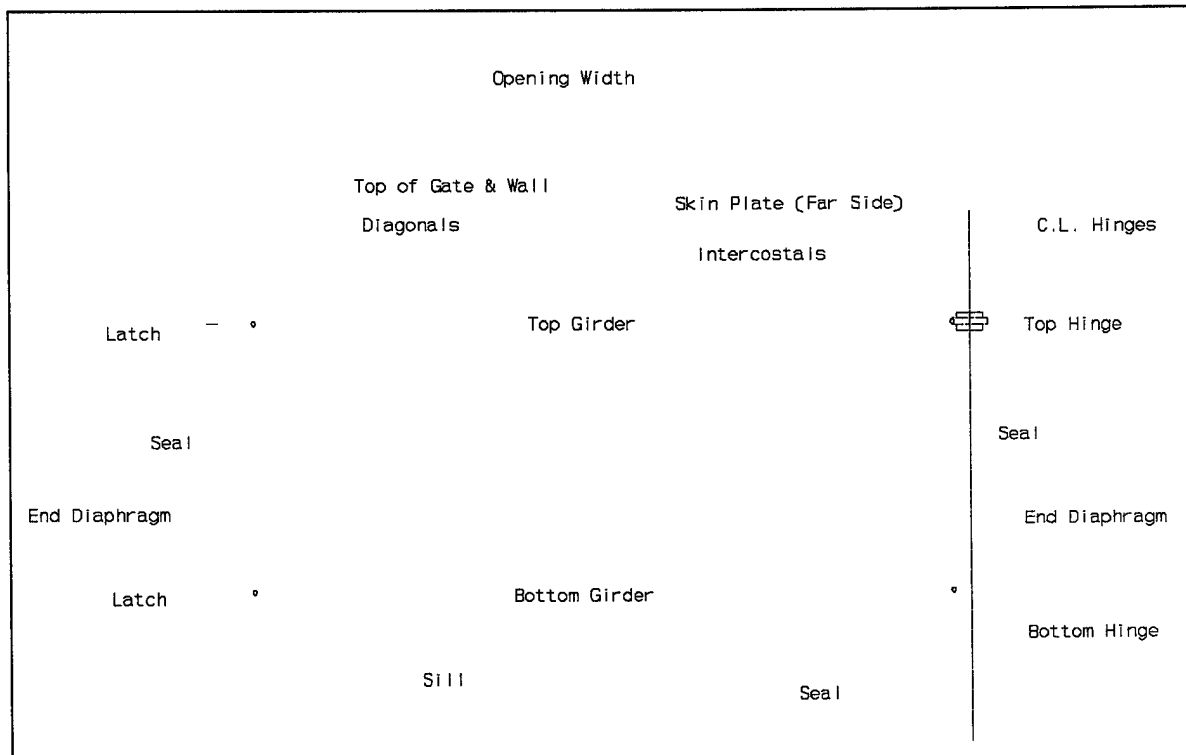

Figure 3-3. Swing gate closure structure

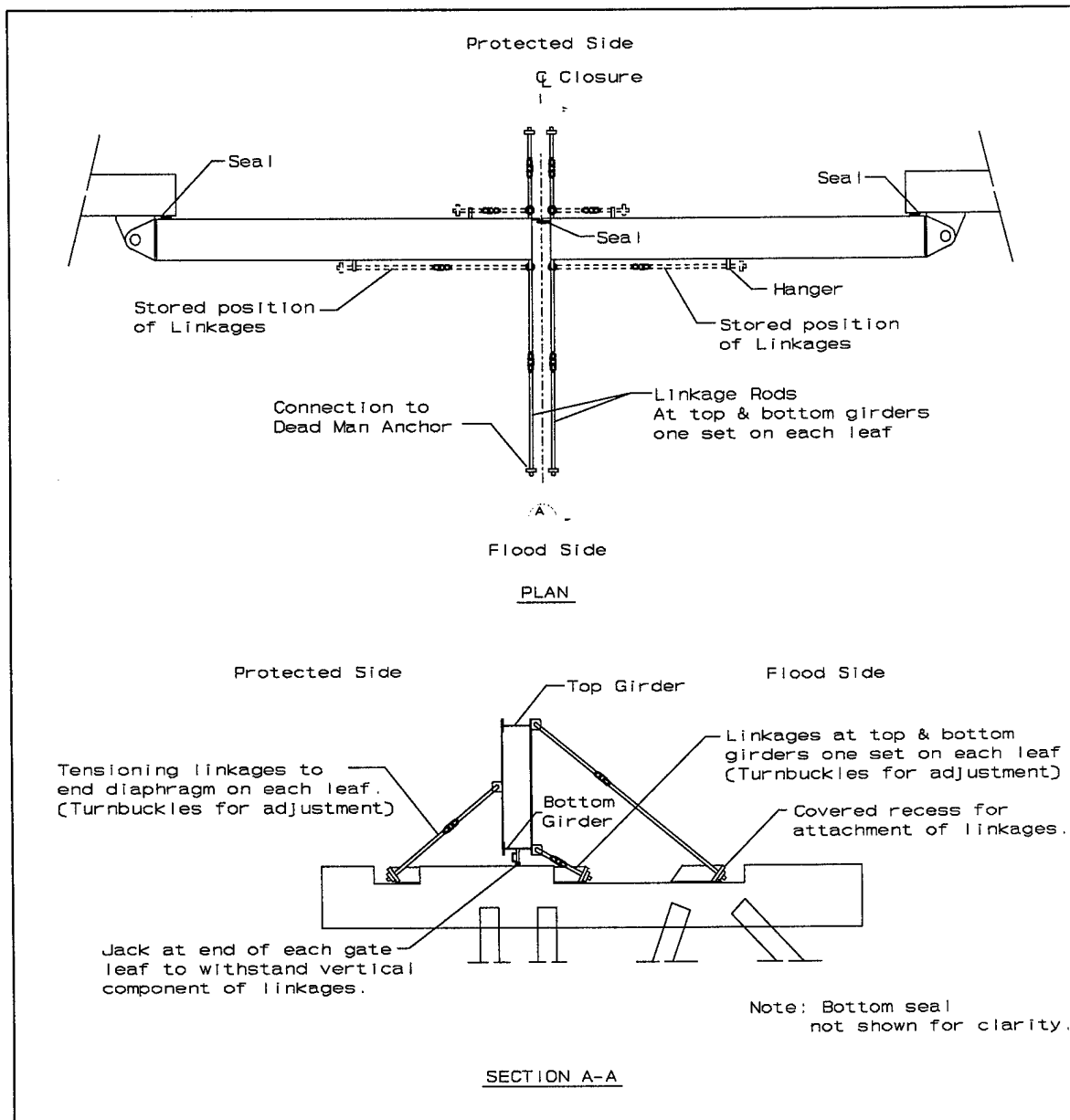

Figure 3-4. Tie-back linkage for double leaf swing gate

- A storage facility is required when removable intermediate support posts are used with double leaf gates.
- Requires a retractable bottom sill to accommodate nonlevel sill surfaces.
- Is difficult to operate during high winds.

(2) Miter gates. Miter gates consist of two leaves that form a three-hinged arch when the gates are in the closed position. Each gate leaf is composed of: horizontal girders, vertical intercostals, vertical end diaphragms, a skin plate, and adjustable diagonal tension rods. The gate leaves are attached to support piers by top and bottom hinges as shown in Figure 3-5. The diagonal tensioning

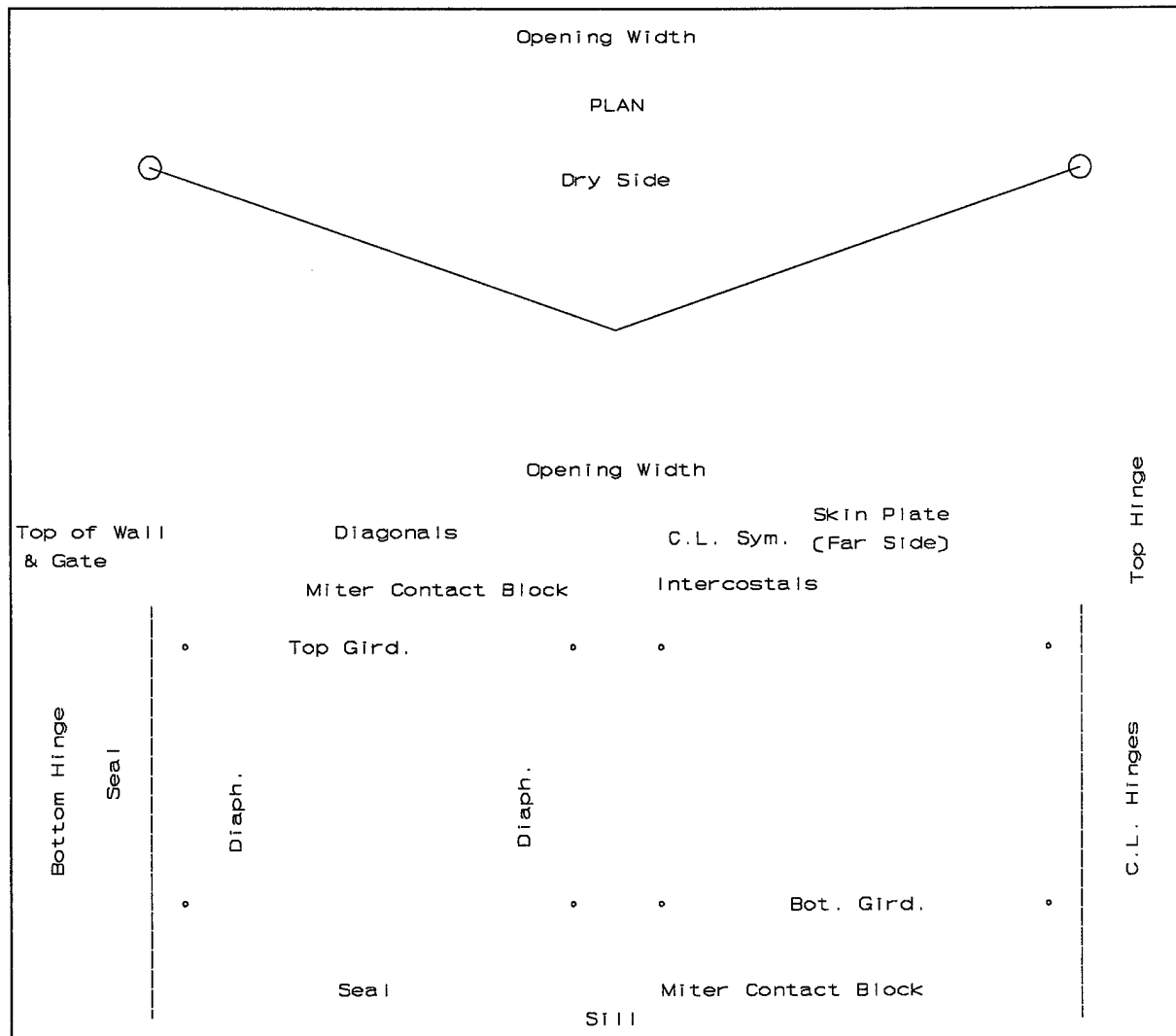

Figure 3-5. Miter gate closure structure

rods are required to prevent twisting of the gate leaves due to their dead load and must be properly tensioned after the gates are installed so that the gates hang plumb and miter properly. Typical diagonal prestressing notes are given in Plate 13. For miter gates with two horizontal girders, the three-hinged arch reactions are resisted by the top and bottom hinges at the supports and spot bearing blocks at the miter ends of the horizontal girders. The magnitude of loading on large miter gates requires the use of three or more horizontal girders, quoin posts with bearings attached to the support piers, and continuous miter posts at the miter ends of the gates to accommodate the forces. Also, hemispherical pintles and top linkages, similar to navigation lock gates, may be required instead

of hinges. Provisions for the design of hemispherical pintles and top linkages are given in EM 1110-2-2703. Hinges and miter blocks or bearing posts must be adjustable to accommodate construction tolerances and allow the gates to miter properly. Support structures for miter gates are usually more difficult to design and cost more than support structures for other types of gates. The supporting structures and their foundations must be designed to minimize the deflections at the gate hinges or quoin posts so that the gates will function as designed. J-seal assemblies are provided for water tightness. Latches are provided to secure the gates in the stored and closed position. Seal, hinge, and latch details for miter gates are similar to those used for swing gates. Closure

31 Mar 94

provisions should include the use of winches or motor vehicles to accomplish closure during strong winds. Typical details of a miter gate closure structure are shown in Plates 14-16. Advantages and disadvantages of miter gate closure structures are given below.

Advantages:

- Is suitable for large openings.
- Closure can be made quickly without the use of skilled personnel.
- A storage building is not required.
- Weighs less than other types of gates designed for large openings.
- A center support is not required.

Disadvantages:

- Requires complex shop fabrication with machine work.
- Requires right-of-way area for operating.
- Support structure is more complex to design and more expensive than for other gate types.
- Requires a retractable bottom seal to accommodate nonlevel sill surfaces.
- Is difficult to operate during high winds.

(3) Rolling gates. Rolling gates are composed of a structural steel frame covered with a water barrier skin plate. The gates are supported by wheels that roll on tracks embedded in the sill across the closure opening and the storage area. J-seals are attached to the ends and bottoms of the gates to form a water-tight seal between the gates and the plates embedded in the end supports and the bottom sill. The gates are sometimes operated by a cable attached to a truck motorized winch; however, the cable could also be connected directly to a truck which pulls the gate open or closed. Alternately, the design may consist of a winch mounted at the site for gate operations. Gates along fast rising streams may be designed to be opened or closed from the protected side of the floodwall as shown in Plates 17-20. Latches should be provided to secure the gates in the stored and closed positions.

(4) Rolling gate - stabilized with two lines of wheels. Rolling gates stabilized with two lines of wheels are composed of: horizontal girders, vertical intercostals, vertical end and intermediate plate diaphragms, a skin plate, and two lines of support wheels as shown in Figure 3-6. The wheels support and stabilize the gate against overturning. The wheels are usually V-grooved castings and roll on tracks that are usually inverted angles with embedded anchorages. The depth of the bottom girder is usually governed by the required transverse spacing between the supporting wheels rather than the hydrostatic load. A girder depth of 30 to 36 in. is normally required to accommodate the spacing between the two lines of wheels to provide stability of the gate during opening and closing operations. Typical details of a rolling gate stabilized with two lines of wheels are shown in Plate 21. Advantages and disadvantages of rolling gates stabilized with two lines of wheels are given below.

Advantages:

- Is adaptable to wide openings.
- Closure can be made quickly without the use of skilled personnel.
- A storage building is not required.
- Requires small storage space.

Disadvantages:

- Requires a retractable bottom seal to accommodate nonlevel sill surfaces.
- Unless wheel assemblies are designed to accommodate the lateral bottom girder deflection, jacks must be provided to lift the wheel assemblies from the tracks when the gate is in the closed position.
- Requires level storage area immediately adjacent to the closure opening.

(5) Rolling gate - with single line of wheels and stabilizing trolleys. These gates are usually composed of a trussed steel frame covered with skin plate or bridge planks. The gates are supported at the bottom by a single line of wheels and are stabilized laterally by an extended top girder supported by trolleys attached to the top of the floodwall as shown in Figure 3-7. Girder depths are usually governed by the hydrostatic loading on the gate.

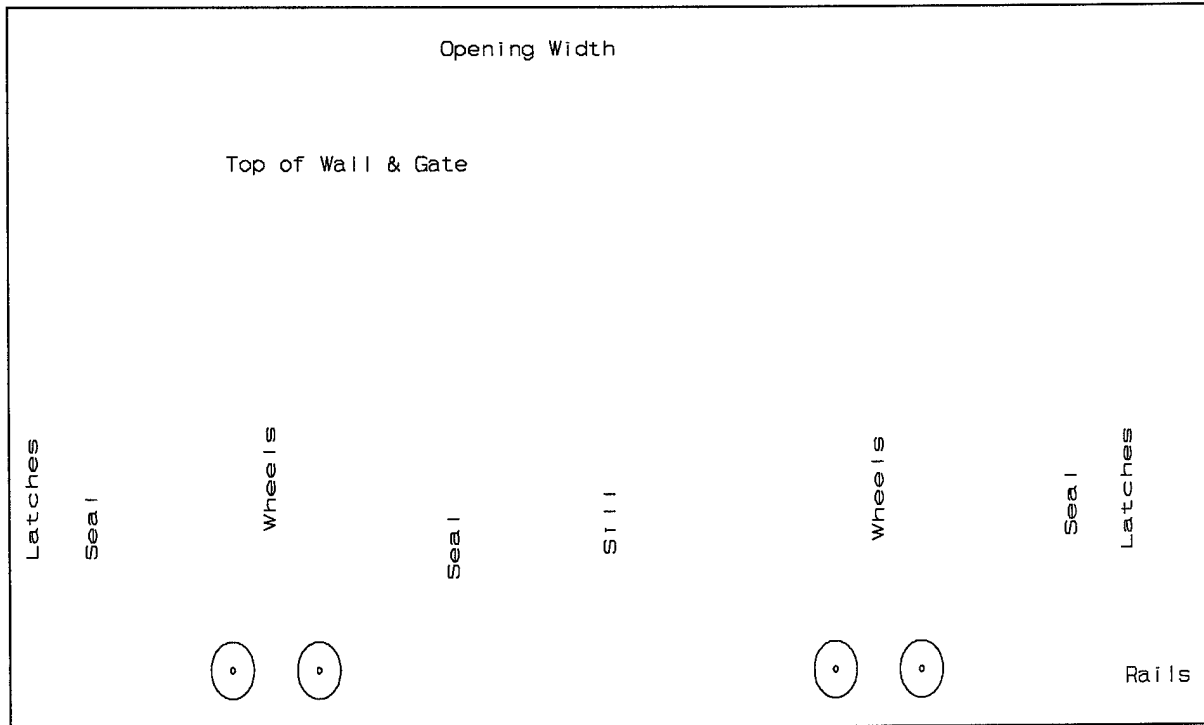

Figure 3-6. Rolling gate - stabilized with two lines of wheels

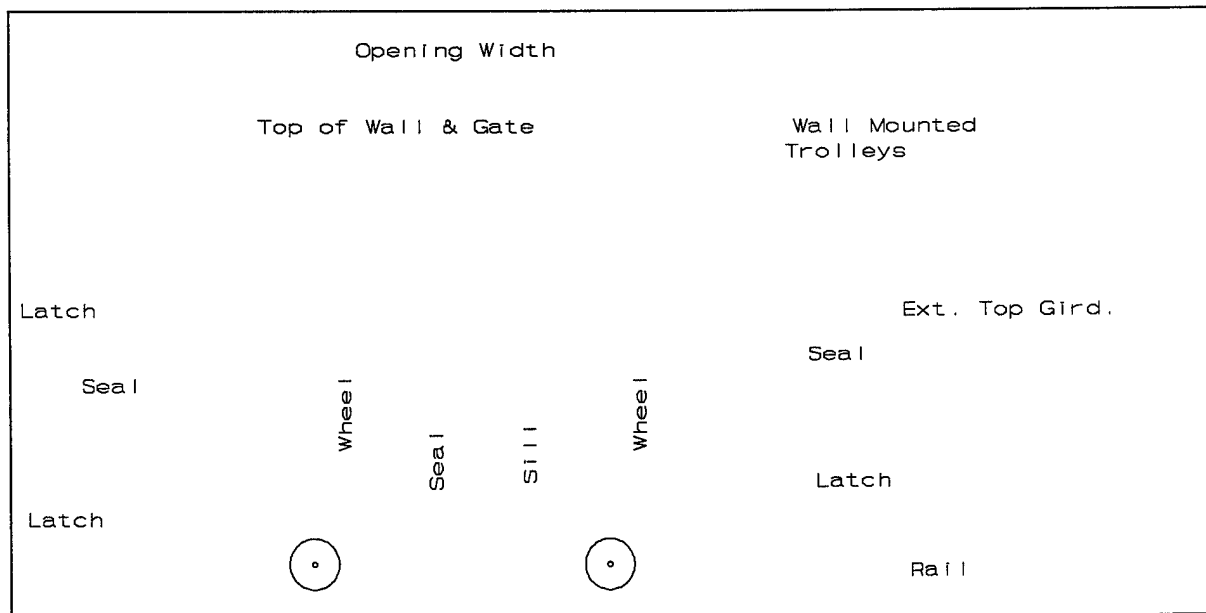

Figure 3-7. Rolling gate - single line of wheels and stabilizing trolleys

Typical details of a rolling gate with a single line of wheels and stabilizing trolleys are shown in Plate 22. Advantages and disadvantages of rolling gates with a single line of wheels and stabilizing trolleys are given below.

Advantages:

- Is practical for closure widths up to 30 ft.
- Closure can be made quickly without the use of skilled personnel.
- A storage building is not required.
- Requires small storage space.

Disadvantages:

- Requires a retractable bottom seal to accommodate nonlevel sill surfaces.
- Requires level storage area immediately adjacent to the closure opening.

(6) Rolling gate - L-frame. These gates are usually composed of a series of L-shaped structural steel frames interconnected by horizontal and diagonal members. The gates are supported at the bottom by two lines of wheels as shown in Figure 3-8. Hooks attached to the heel of each of the L-frames engage anchorages embedded in the concrete sill structure to stabilize the gate against hydrostatic loadings. Typical details of an L-frame rolling gate are shown in Plate 23. Advantages and disadvantages of L-frame rolling gates are given below.

Advantages:

- Can be designed for any opening width.
- Can be shop-fabricated in sections to simplify handling and storage.
- Closure can be made quickly without the use of skilled personnel.
- A storage building is not required.

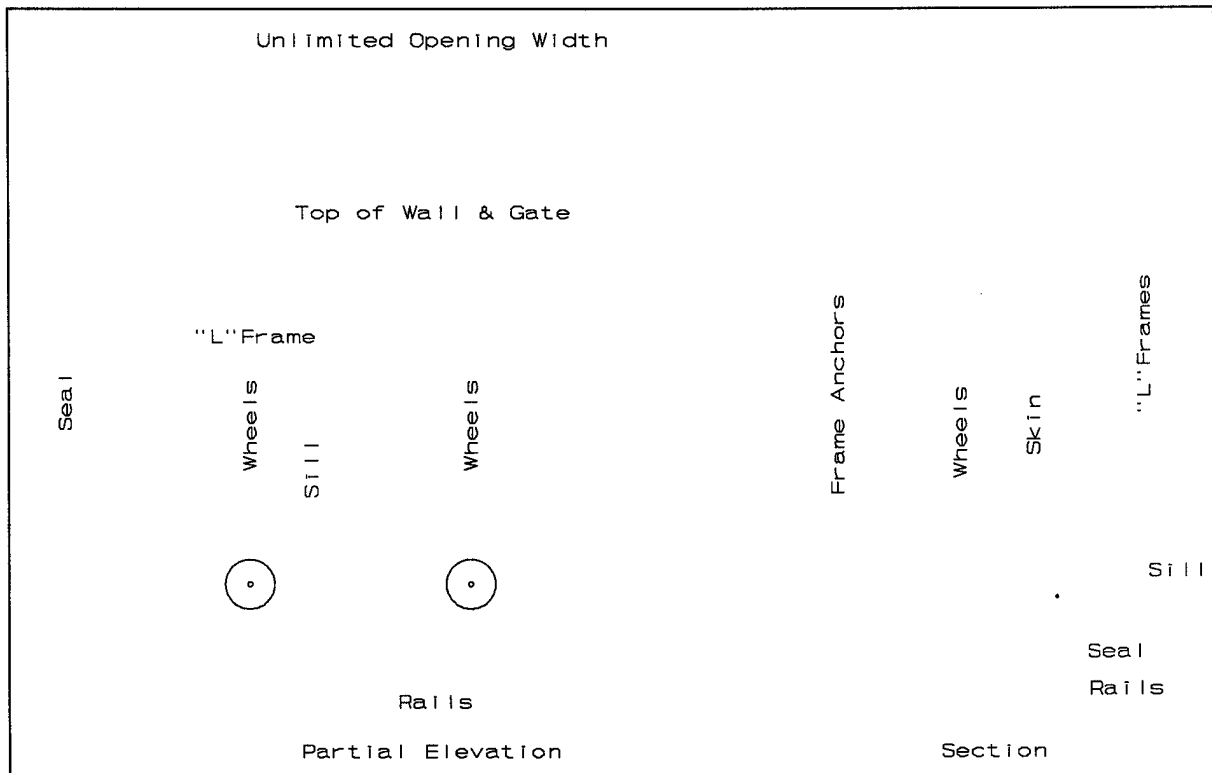

Figure 3-8. Rolling gate - L-frame stabilized by hooks

- Requires small storage space.

Disadvantages:

- Requires a retractable bottom seal to accommodate nonlevel sill surfaces.
- Requires level track surface.
- Requires level storage area immediately adjacent to the closure opening.
- Requires wide sill to accommodate the installation of tracks and hook anchorages.

(7) Trolley Gates. Trolley gates are usually composed of top and bottom horizontal girders, other secondary framing members, and a skin plate. Trolley gates are suspended from trolleys running on an overhead rail and beam supported by the floodwall as shown in Figure 3-9. The gates are opened and closed by a winch arrangement

similar to that used for rolling gates. Typical details of a trolley gate closure structure are shown in Plate 24. Advantages and disadvantages of a trolley gate closure structure are given below.

Advantages:

- Is practical for closure widths up to 60 ft.
- Closure can be made quickly without the use of skilled personnel.
- Can obtain a good seal against irregular sill surfaces.
- A storage building is not required.
- Requires small storage space.
- Is suitable for railroad closures because required vertical clearances for railroads are fixed.

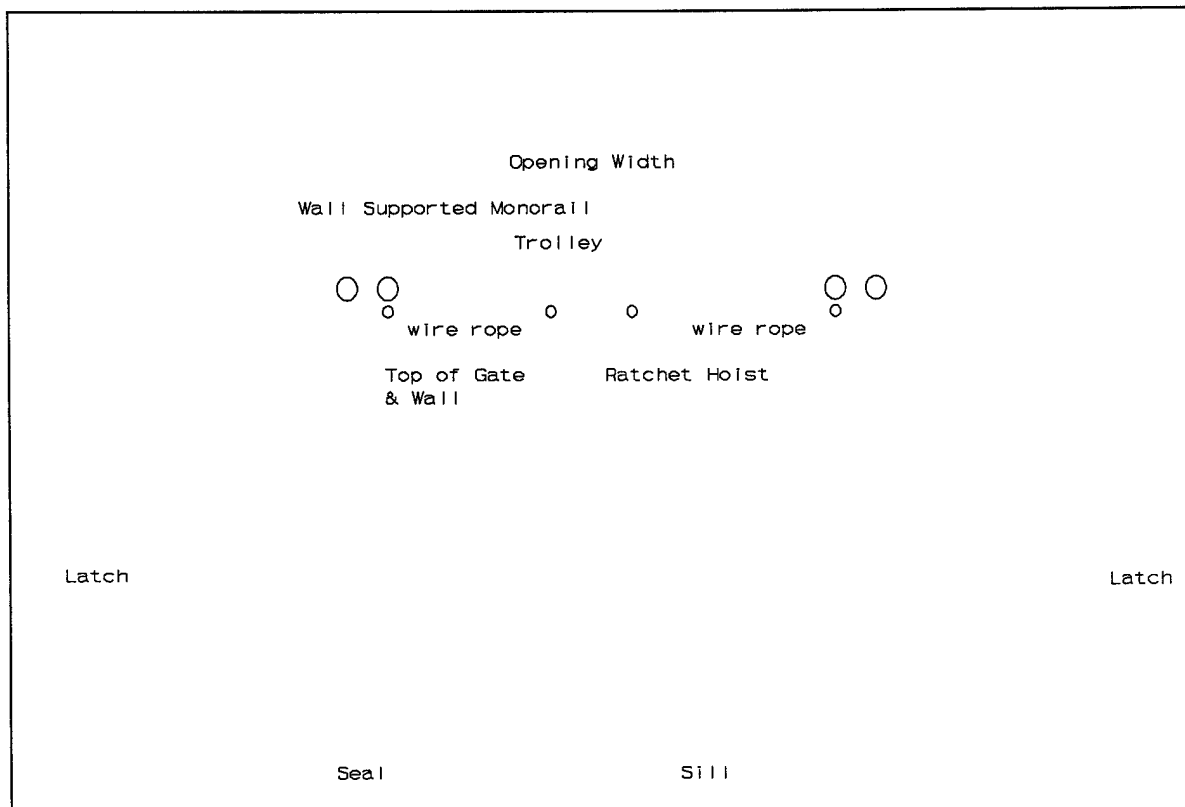

Figure 3-9. Trolley gate

EM 1110-2-2705
31 Mar 94

Disadvantages:

- Slope of the ground adjacent to the closure opening must allow adequate clearance to open the gate.

- May be rendered inoperative due to permanent overhead support members being damaged by vehicles or other sources, or removable overhead support members or their anchorages being damaged during removal or placement operations.

- A guide member at the base of the gate may be required to support the gate against wind loads during opening and closing operations.

- c. Prefabricated stoplogs and gates.* Prefabricated stoplogs and gates are commercially available and are usually more cost effective for closure structures with small openings.

Chapter 4 Structural Analyses and Design

4-1. Stress Criteria

a. Concrete. Criteria for the design of reinforced concrete elements of the closure structures are given in EM 1110-2-2104.

b. Structural steel. Criteria for the design of structural steel closure gates shall be based on the provisions given in EM 1110-2-2105. Design for the normal (usual) load cases shall limit the allowable stress to 5/6 of the allowable given in AISC (1986). This "5/6" modification factor is used because Corps criteria require a higher safety factor for hydraulic structures than AISC uses for building design. Allowable stresses 1/3 greater than the normal stresses shall be used for load cases that include water to the top of the closure, wind, earthquake, or short duration loads. Load and resistance factor design criteria for structural steel closure gates are provided in EM 1110-2-2105 and AISC (1986).

c. Structural aluminum. The design of aluminum shall be based on the provisions of the Aluminum Association (1986). The allowable stress shall be limited to 5/6 of the basic values given therein for normal load cases. This allowable stress should be increased by 1/3 for design cases that include water to the top of closures, wind, earthquake, or short duration loads.

4-2. Loading Criteria

Load cases I1 through I4, given in Chapter 4 of EM 1110-2-2502 for the design of inland flood walls, shall be used for the design of closure structures. An additional load case, Case I5, is included for the design of the gate hinges and support structure for swinging gates. These load cases are described below. Load cases for closure structures loaded in coastal areas are given in Table 4-3 of EM 1110-2-2502.

a. Case I1, Design flood load. Closure in the closed position; water level on the unprotected side at the design flood level (top of wall less freeboard); water level on the unprotected side at or below the gate sill elevation.

b. Case I2, Maximum flood load. Same as Case I1 except water level is at the top of the closure on the unprotected side.

c. Case I3, Earthquake load. Water level at the usual water elevation during the nonflood stage; earthquake-induced lateral and vertical loads are acting. (Note: This case is applicable to support structures only.)

d. Case I4, Short-duration loading. Closure is subjected to short-duration loads with the gate in any position. The gate should be designed for a wind load of 15 psf during opening and closing and for a wind load as specified in EM 1110-2-2502 when the gate is in the closed position. Other special loads may be necessary for closures in hurricane flood structures to ensure safe operation during gate closures. For example, gates could be subjected to storm wave loadings during gate closing operations if gate closure is delayed as long as possible to allow for the movement of railway traffic during a storm.

e. Case I5, Gate swinging. Hinged gate of a gate closure in any position; subjected to dead load only.

4-3. Design Analysis Criteria

The design analysis criteria for closure structures are presented in detail in the design examples included in Appendices B through F. Provisions for designing and determining the stability of supporting posts, walls, and sills of closures are not included in this guidance. Chapters 4 and 5 of EM 1110-2-2502 should be referred to for overturning and sliding stability requirements. Flotation criteria are given in EM 1110-2-3104. The design of pile foundations should comply with the criteria in EM 1110-2-2906.

Chapter 5 Appurtenant Components

5-1. Gate Operating Equipment

Gate operating equipment includes motorized vehicles, winches, latches, wire rope, hooks, sheaves, snatch blocks, and other appurtenances. These items should be provided as prescribed herein and as needed for the operation of closure structures.

5-2. Seal Assemblies

Rubber seals should be of the type suitable for the particular application. Seal assemblies should be designed to fit

the configuration of the gates and gate sills. Hinged bottom seal assemblies, similar to the details shown in Plate 10 are adaptable to uneven or broken sill configurations. This seal assembly is raised to clear the roadway grade during gate movements to prevent damage to the rubber seals.

5-3. Embedded Metals

Embedded structural steel bearing plates and anchorages must be provided as required for the installation of gates and appurtenances. Embedded seal plates shall be galvanized steel, stainless clad steel, or solid stainless steel for the prevention of corrosion. The edges of embedded seal plates should extend approximately 2 in. beyond the sealing surface.

Chapter 6

Corrosion Protection

6-1. Criteria

Criteria for corrosion protection of metals are given in EM 1110-2-21-5 and EM 1110-2-3400.

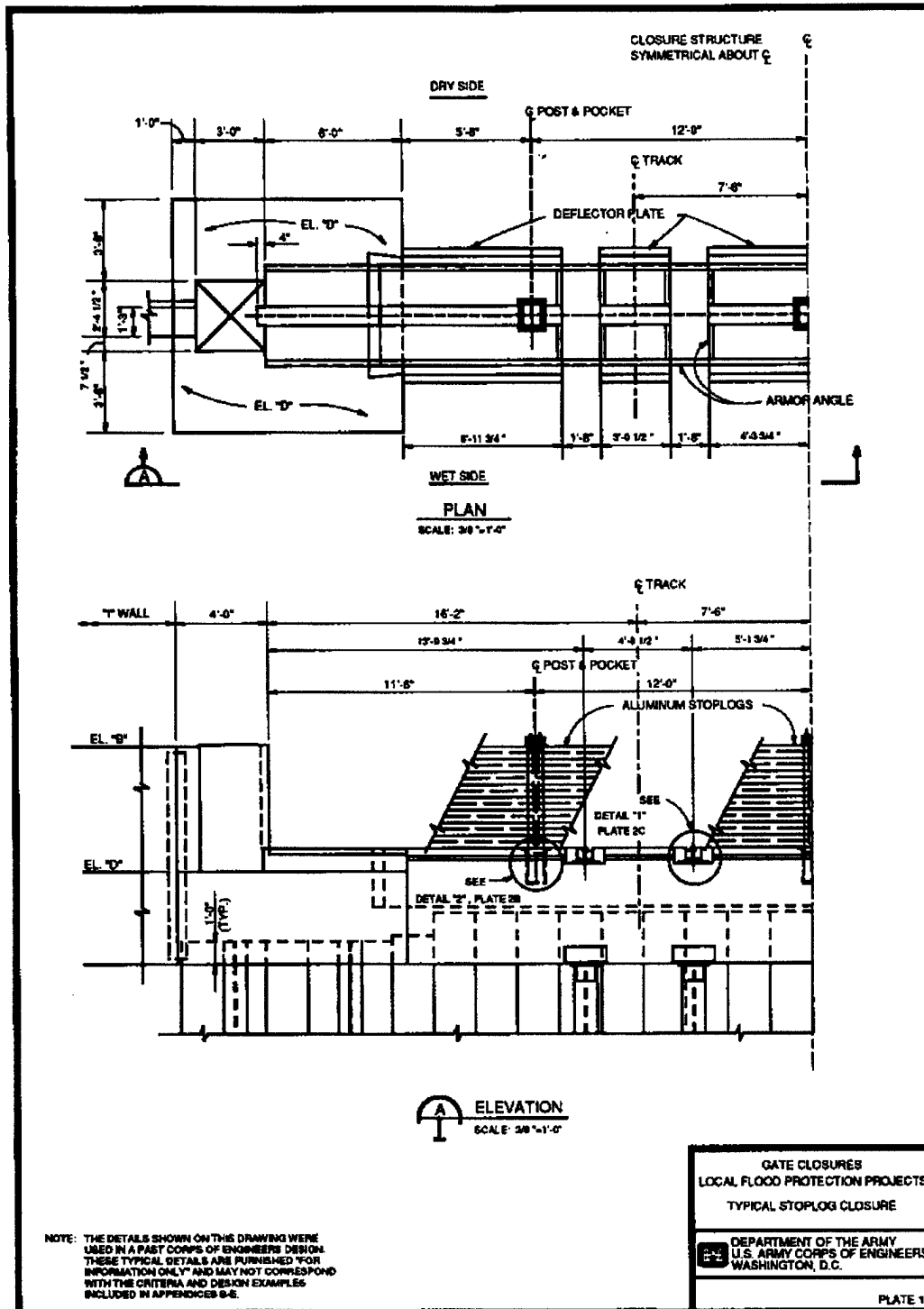

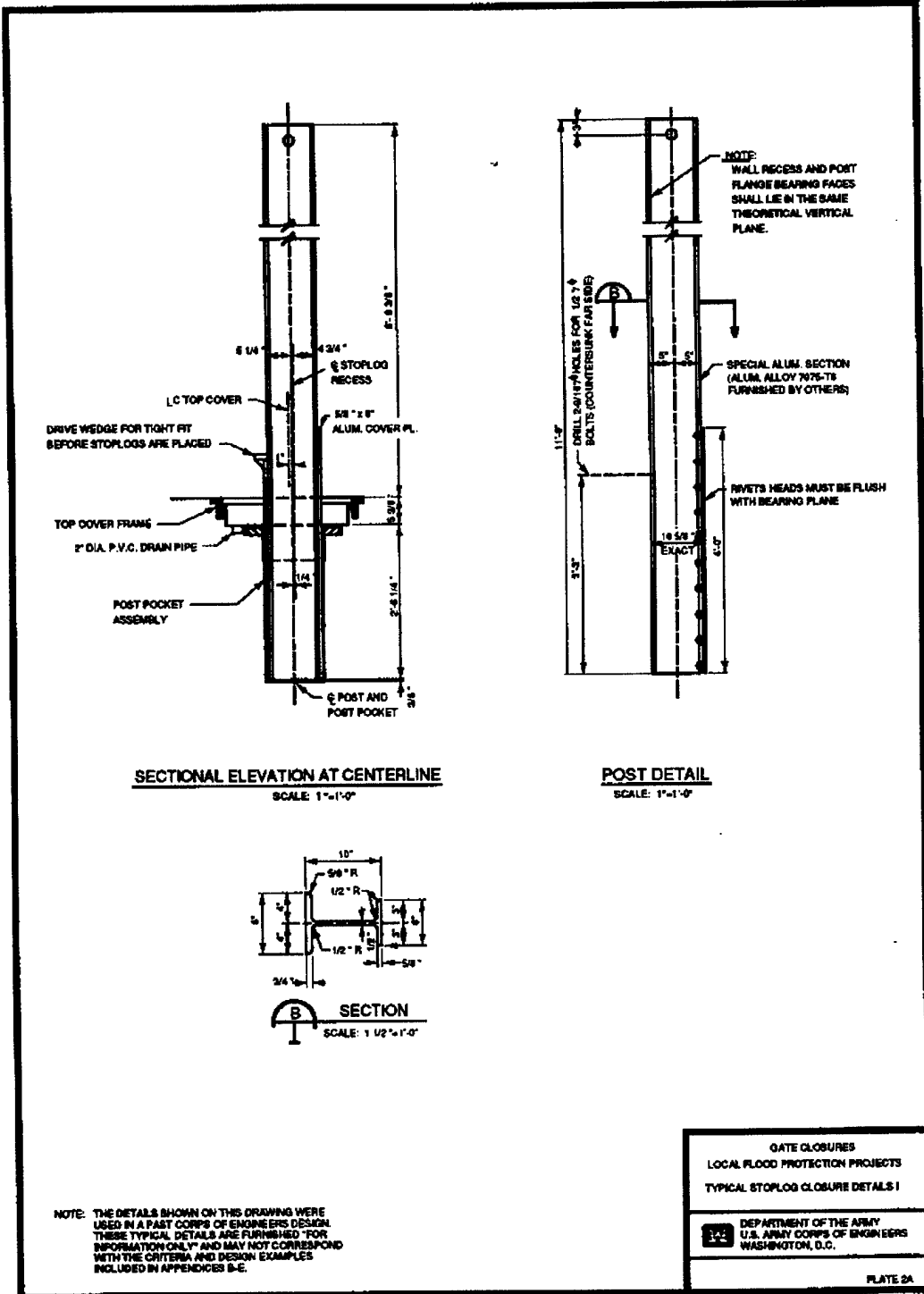

SECTIONAL ELEVATION AT CENTERLINE
SCALE: 1"=1'-0"

POST DETAIL
SCALE: 1"=1'-0"

SECTION
SCALE: 1 1/2"=1'-0"

NOTE: THE DETAILS SHOWN ON THIS DRAWING WERE USED IN A PAST CORPS OF ENGINEERS DESIGN. THESE TYPICAL DETAILS ARE FURNISHED FOR INFORMATION ONLY AND MAY NOT CORRESPOND WITH THE CRITERIA AND DESIGN EXAMPLES INCLUDED IN APPENDICES B-E.

GATE CLOSURES
LOCAL FLOOD PROTECTION PROJECTS
TYPICAL STOPLOG CLOSURE DETAILS I

DEPARTMENT OF THE ARMY
U.S. ARMY CORPS OF ENGINEERS
WASHINGTON, D.C.

PLATE 2A

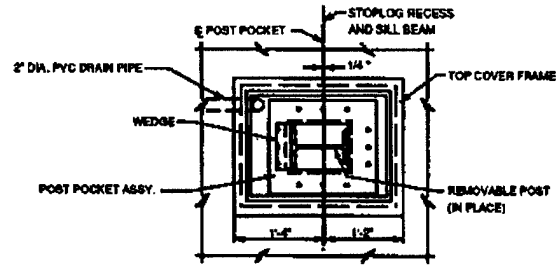

SECTION A
SCALE: 1"=1'-0"

EMBEDDED POCKET WITH POST IN PLACE
SCALE: 1"=1'-0"

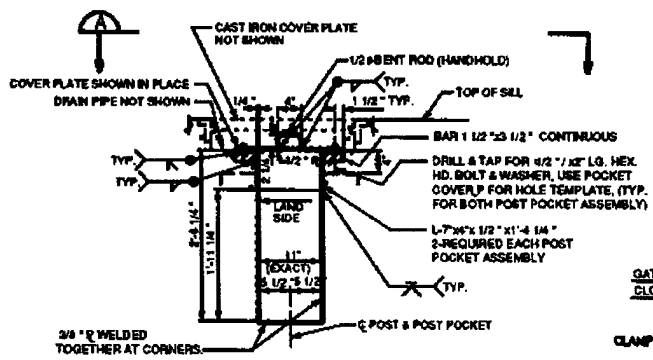

DETAIL 2
SCALE: 1"=1'-0"

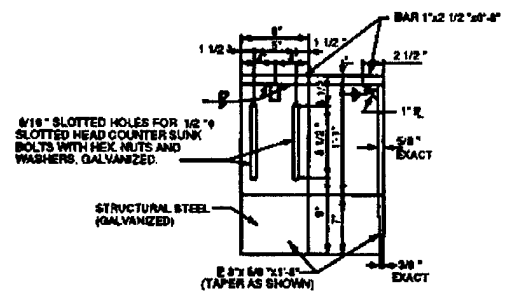

WEDGE DETAIL
SCALE: 1 1/2"=1'-0"

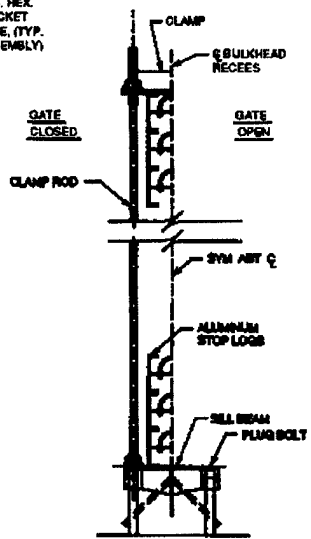

CLAMP ANCHOR ASSEMBLY
SCALE: NONE

NOTE: THE DETAILS SHOWN ON THIS DRAWING WERE USED IN A PAST CORPS OF ENGINEERS DESIGN. THESE TYPICAL DETAILS ARE FURNISHED FOR INFORMATION ONLY AND MAY NOT CORRESPOND WITH THE CRITERIA AND DESIGN EXAMPLES INCLUDED IN APPENDICES B-6.

<p>GATE CLOSURES LOCAL FLOOD PROTECTION PROJECTS TYPICAL STOPLOG CLOSURE DETAILS #</p>
<p>DEPARTMENT OF THE ARMY U.S. ARMY CORPS OF ENGINEERS WASHINGTON, D.C.</p>
<p>PLATE 28</p>

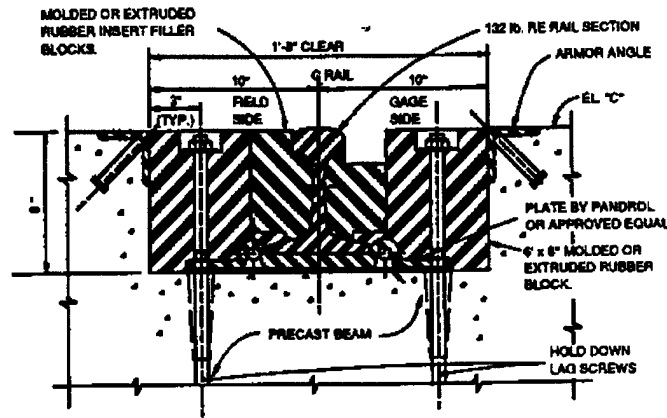

DETAIL 1
RAIL ASSEMBLY
 SCALE: 3/4"=1'-0"

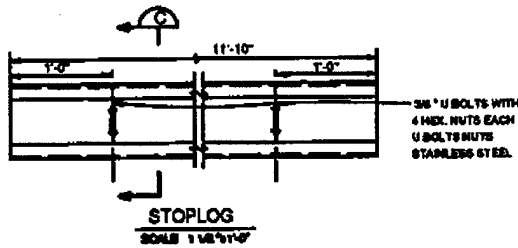

STOPLOG
 SCALE: 1/8"=1'-0"

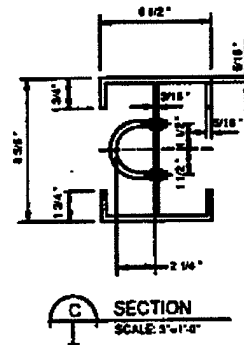

SECTION
 SCALE: 3/4"=1'-0"

NOTE: THE DETAILS SHOWN ON THIS DRAWING WERE USED IN A PAST CORPS OF ENGINEERS DESIGN. THESE TYPICAL DETAILS ARE FURNISHED FOR INFORMATION ONLY AND MAY NOT CORRESPOND WITH THE CRITERIA AND DESIGN EXAMPLES INCLUDED IN APPENDICES B-E.

GATE CLOSURES
 LOCAL FLOOD PROTECTION PROJECTS
 TYPICAL STOPLOG CLOSURE DETAILS II

DEPARTMENT OF THE ARMY
 U.S. ARMY CORPS OF ENGINEERS
 WASHINGTON, D.C.

PLATE 2C

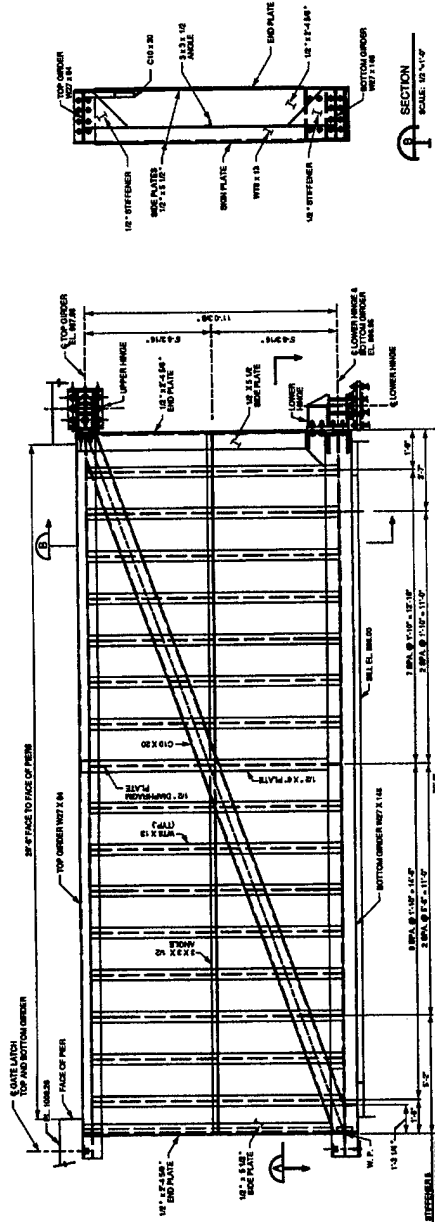

WET SIDE ELEVATION
SCALE: 1/8" = 1'-0"

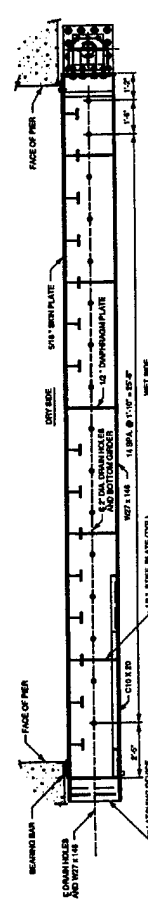

SECTION
SCALE: 1/8" = 1'-0"

- NOTE:
1. TYPICAL REINFORCING DETAILS ARE SHOWN
 2. TYPICAL LATERAL DETAIL ARE SHOWN
 3. TYPICAL WALL DETAILS ARE SHOWN

NOTE: THE DETAILS SHOWN ON THIS DRAWING WERE DEVELOPED BY THE ENGINEER AND ARE SUBJECT TO THE APPROVAL OF THE DISTRICT ENGINEER. THESE TYPICAL DETAILS ARE FOR GENERAL INFORMATION ONLY. THE CONTRACTOR SHALL BE RESPONSIBLE FOR VERIFYING THE DETAILS AND MATERIALS WITH THE CONTRACTOR AND DISTRICT ENGINEER. DETAILS NOT SHOWN ARE TO BE INCLUDED IN APPROVED BY CONTRACTOR.

GATE DESIGN LOCAL FLOOD PROTECTION PROJECTS TYPICAL BRIDGE GATE DEPARTMENT OF THE ARMY WASHINGTON, D.C.	57 WASHINGTON, D.C.
---	------------------------

PLATES

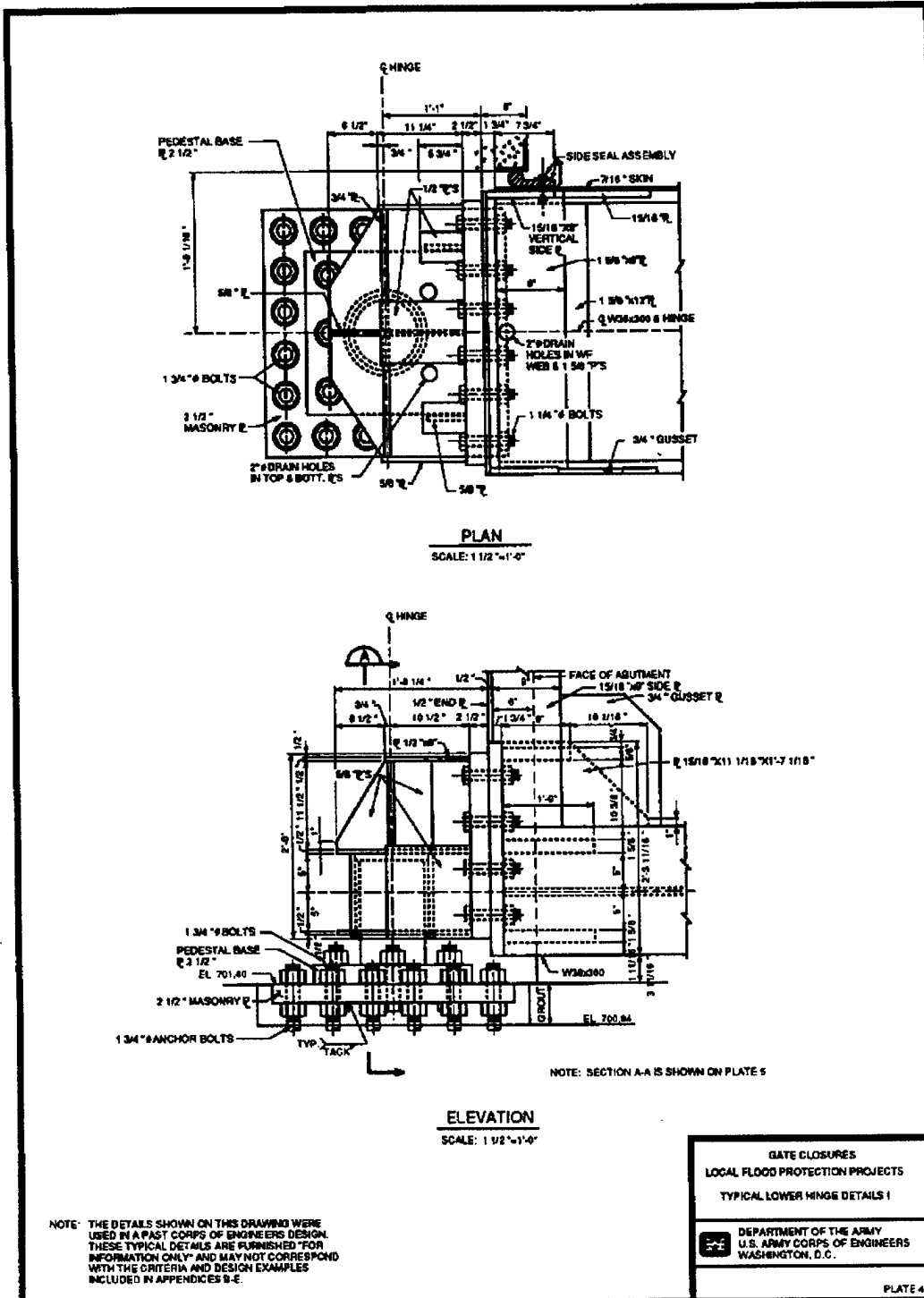

REQUIRED LIST						
MARK	NO. REQ.	DESCRIPTION	MATERIAL	EST. WT (LBS. EA.)	USED WITH	REMARKS
13/1	1	BUSHING	BRONZE		13/13	ASTM B22 UNS NO. C91300
13/2	1	HINGE PIN	STAINLESS STEEL			ASTM A276 TYPE XM19
13/3	1	RECESSED PIN NUT	CRCS		13/2	
13/4	1	THRUST WASHER	BRONZE		13/6	ASTM B22 UNS NO. C91300
13/5	1	BUSHING	BRONZE		13/14	ASTM B22 UNS NO. C91300
13/6	1	BEARING PEDESTAL	STAINLESS STEEL	156	13/7	ASTM A276 TYPE XM19
13/7	1	PEDESTAL BASE PLATE	STAINLESS STEEL	271	13/6	ASTM A240
13/8	20	ANCHOR BOLT	SEE NOTE A			
13/9	20	ANCHOR PLATE	STEEL	70	13/6	ASTM A-36
13/10	AS REQ'D	SHIM PLATE	STEEL		TOP HINGE	ASTM A-36
13/11	10	ANCHOR PLATE		407	TOP HINGE	
13/12	10	ANCHOR PLATE	STEEL	35	13/11	ASTM A-26
13/13	1	OUTER CYLINDER	STEEL	26	13/1	ASTM A-53 GRADE B OR
13/14	1	OUTER CYLINDER	STEEL		13/5	ASTM A-501
13/A	8	1 3/4" X 3 3/8" HEX HD BOLT (2 1/4" THD LG) W/HEAVY HEX NUT & WASHER	SEE NOTE A		BOTT. HINGE	
13/B	1	GREASE SEAL #051 NO. 582607 AS MFR BY C.R.I.N.D. OR APP. EQUAL 10.0" O.D.				COMMERCIAL GRADE
13/C	2	GREASE FITTING 1/8" NPT TYPE				COMMERCIAL GRADE
13/D	20	1 1/4" X 3/8" 1/4" HEX HD BOLT (2 3/4" THD LG) W/HEAVY HEX NUT & WASHER	SEE NOTE A		BOTT. HINGE	
13/E	8	SET SCREW-HEX SOCKET 1 1/4" X 3/8" 3/8" CLASS #3 W/HEX JAM NUTS	STEEL		TOP HINGE	ASTM A-325
13/F	2	GREASE SEAL "C.R.I.N.D. TYPE CRWHT #30033"-3.60" I.D. OR APP. EQUAL				COMMERCIAL GRADE
13/G	10	1 1/2" X 3/8" 1/4" (2 3/4" THD LG) W/HEAVY HEX NUT & FLAT WASHER	SEE NOTE A		TOP HINGE	

NOTE "A": A.S.T.M. A-185, CLASS I-C, GRADE B8R OR B8RA BOLTS
WITH ASTM A184 TYPE 203, OR AFA HEAVY HEX NUTS.
NOTE: QUANTITIES SHOWN ARE FOR ONE GATE ONLY.
NOTE: 1. ALL STEEL ASTM A36, UNLESS OTHERWISE NOTED.

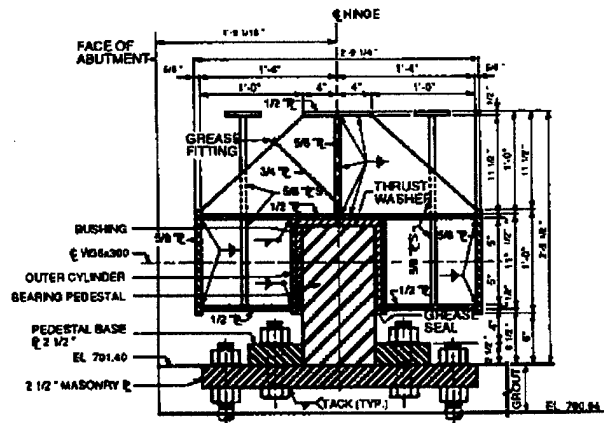

SECTION
SCALE 1/2" = 1"

NOTE: THE DETAILS SHOWN ON THIS DRAWING WERE
USED IN A PART CORPS OF ENGINEERS DESIGN
THESE TYPICAL DETAILS ARE FURNISHED FOR
INFORMATION ONLY AND MAY NOT CORRESPOND
WITH THE CRITERIA AND DESIGN EXAMPLES
INCLUDED IN APPENDICES B-E

GATE CLOSURES
LOCAL FLOOD PROTECTION PROJECTS
TYPICAL LOWER HINGE DETAILS II

DEPARTMENT OF THE ARMY
U.S. ARMY CORPS OF ENGINEERS
WASHINGTON, D.C.

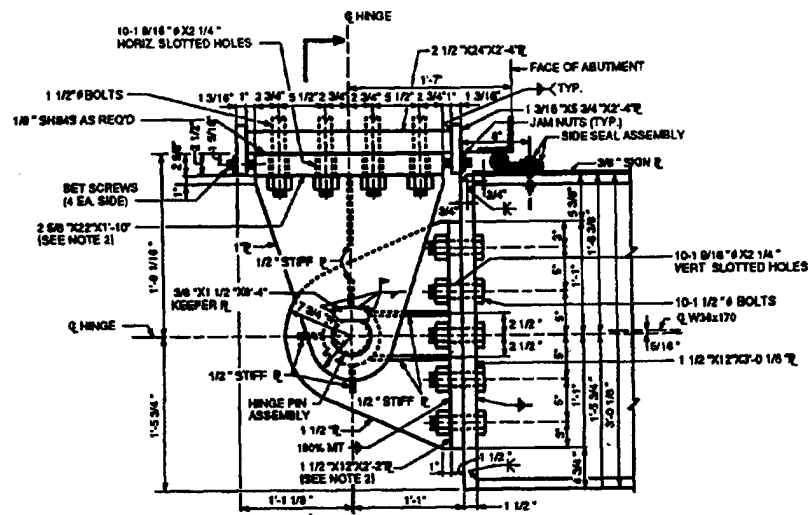

NOTE: SECTION A-A IS SHOWN ON PLATE 7

PLAN
SCALE 1/2"=1'-0"

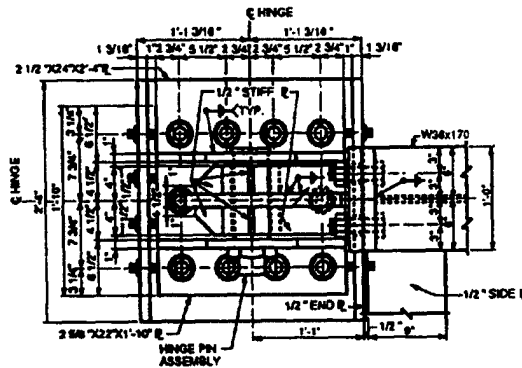

ELEVATION
SCALE 1/2"=1'-0"

NOTES:

1. ALL STEEL ASTM A36 UNLESS OTHERWISE NOTED.
2. THESE PLATES TO BE 100% ULTRASONIC TESTED FOR LAMINATIONS.

NOTE: THE DETAILS SHOWN ON THIS DRAWING WERE USED IN A PAST CORPS OF ENGINEERS DESIGN. THESE TYPICAL DETAILS ARE FURNISHED "FOR INFORMATION ONLY" AND MAY NOT CORRESPOND WITH THE CRITERIA AND DESIGN EXAMPLES INCLUDED IN APPENDICES B-E

GATE CLOSURES
LOCAL FLOOD PROTECTION PROJECTS
TYPICAL UPPER HINGE DETAILS I

DEPARTMENT OF THE ARMY
U.S. ARMY CORPS OF ENGINEERS
WASHINGTON, D.C.

PLATE 8

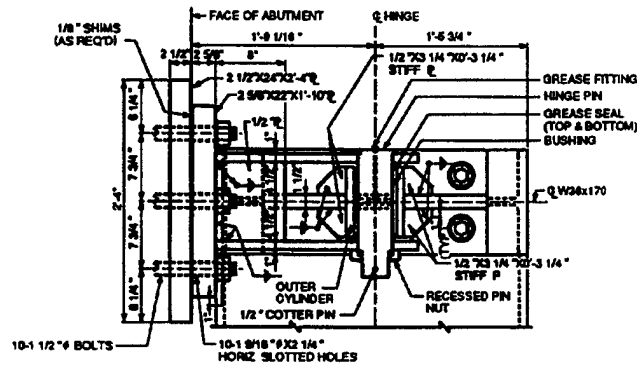

SECTION
SCALE 1 1/2"=1'-0"

NOTES:

1. ALL STEEL ASTM A36 UNLESS OTHERWISE NOTED.
2. THESE PLATES TO BE 100% ULTRASONIC TESTED FOR LAMINATIONS.

NOTE: THE DETAILS SHOWN ON THIS DRAWING WERE USED IN A PAST CORPS OF ENGINEERS DESIGN. THESE TYPICAL DETAILS ARE FURNISHED FOR INFORMATION ONLY AND MAY NOT CORRESPOND WITH THE CRITERIA AND DESIGN EXAMPLES INCLUDED IN APPENDICES B-E.

<p>GATE CLOSURES LOCAL FLOOD PROTECTION PROJECTS TYPICAL UPPER HINGE DETAILS II</p>
 <p>DEPARTMENT OF THE ARMY U.S. ARMY CORPS OF ENGINEERS WASHINGTON, D.C.</p>
<p>PLATE 7</p>

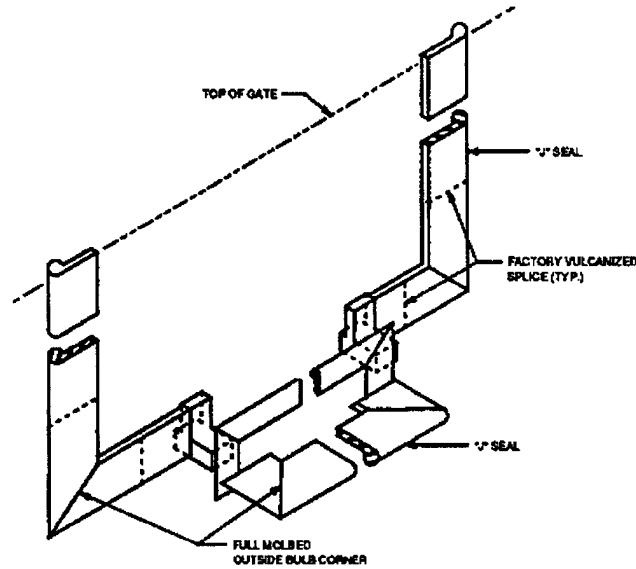

LAYOUT OF GATE SEAL
N.T.S.

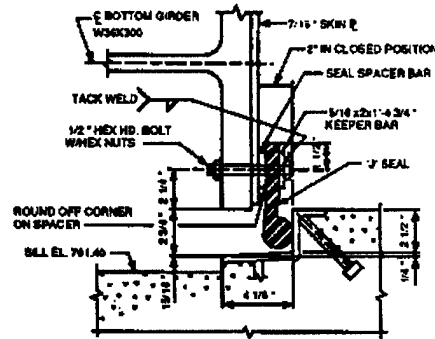

TYPICAL FIXED BOTTOM SEAL
SCALE: 3/4"=1'-0"

NOTES:

1. ALL STEEL ASTM A36, UNLESS OTHERWISE NOTED
2. ALL SEAL BOLTS AND NUTS SHALL BE CRES.
3. 1/2" SEALS TO HAVE 50 TO 86 DUROMETER HARDNESS.

NOTE: THE DETAILS SHOWN ON THIS DRAWING WERE USED IN A PAST CORPS OF ENGINEERS DESIGN. THESE TYPICAL DETAILS ARE FURNISHED "FOR INFORMATION ONLY" AND MAY NOT CORRESPOND WITH THE CRITERIA AND DESIGN EXAMPLES INCLUDED IN APPENDICES B-E.

GATE CLOSURES LOCAL FLOOD PROTECTION PROJECTS TYPICAL SEAL DETAILS I
 DEPARTMENT OF THE ARMY U.S. ARMY CORPS OF ENGINEERS WASHINGTON, D.C.
PLATE 6

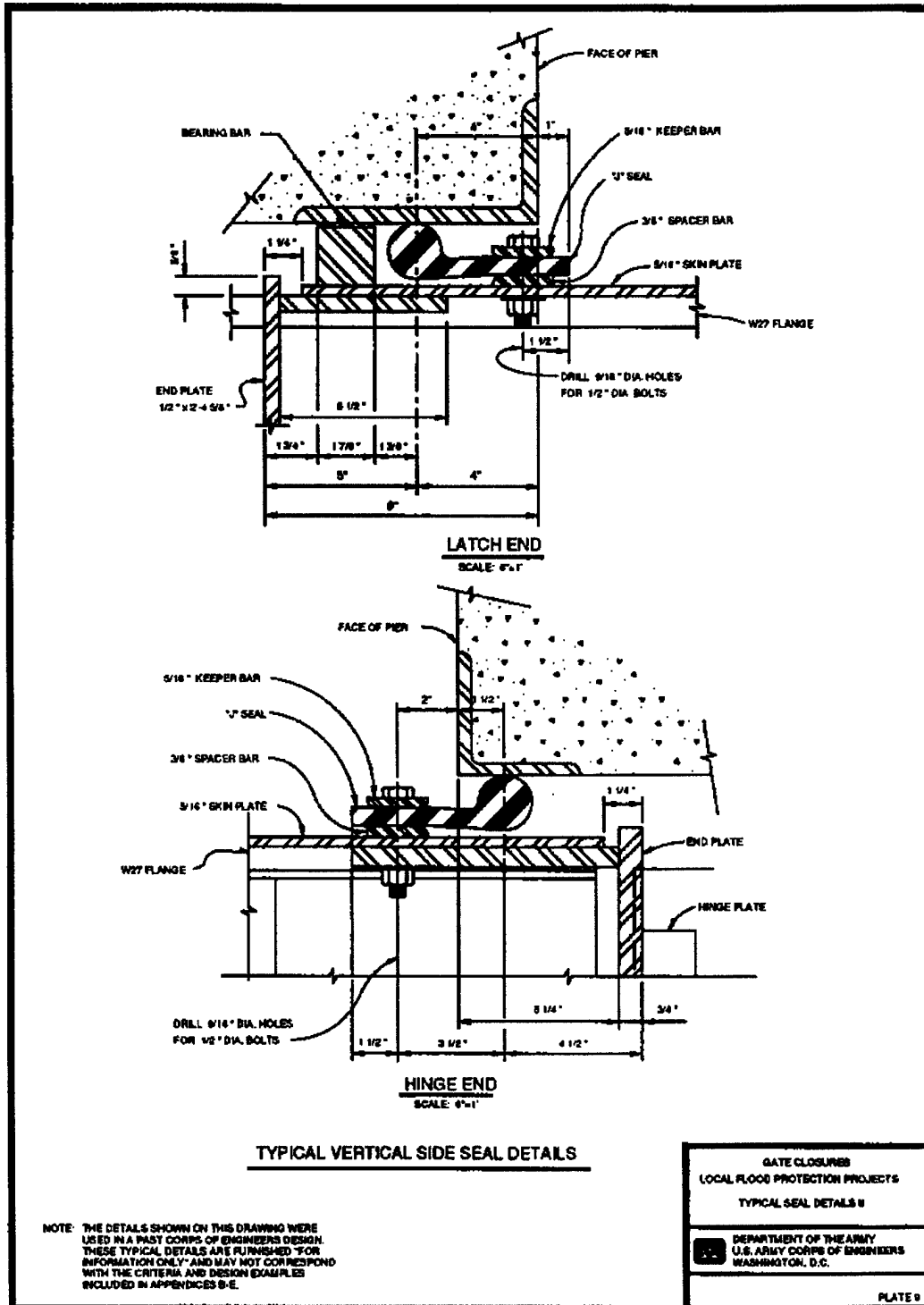

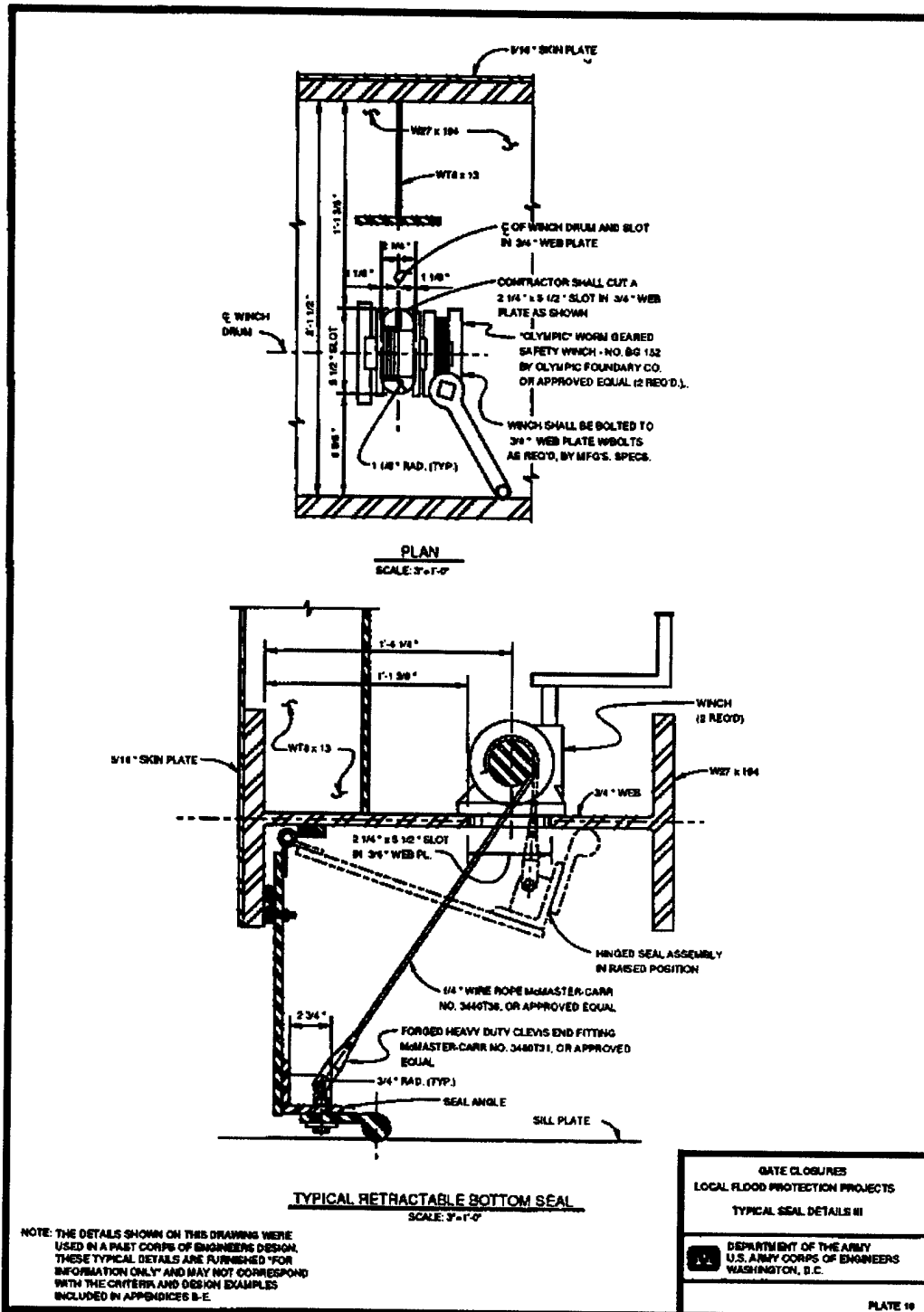

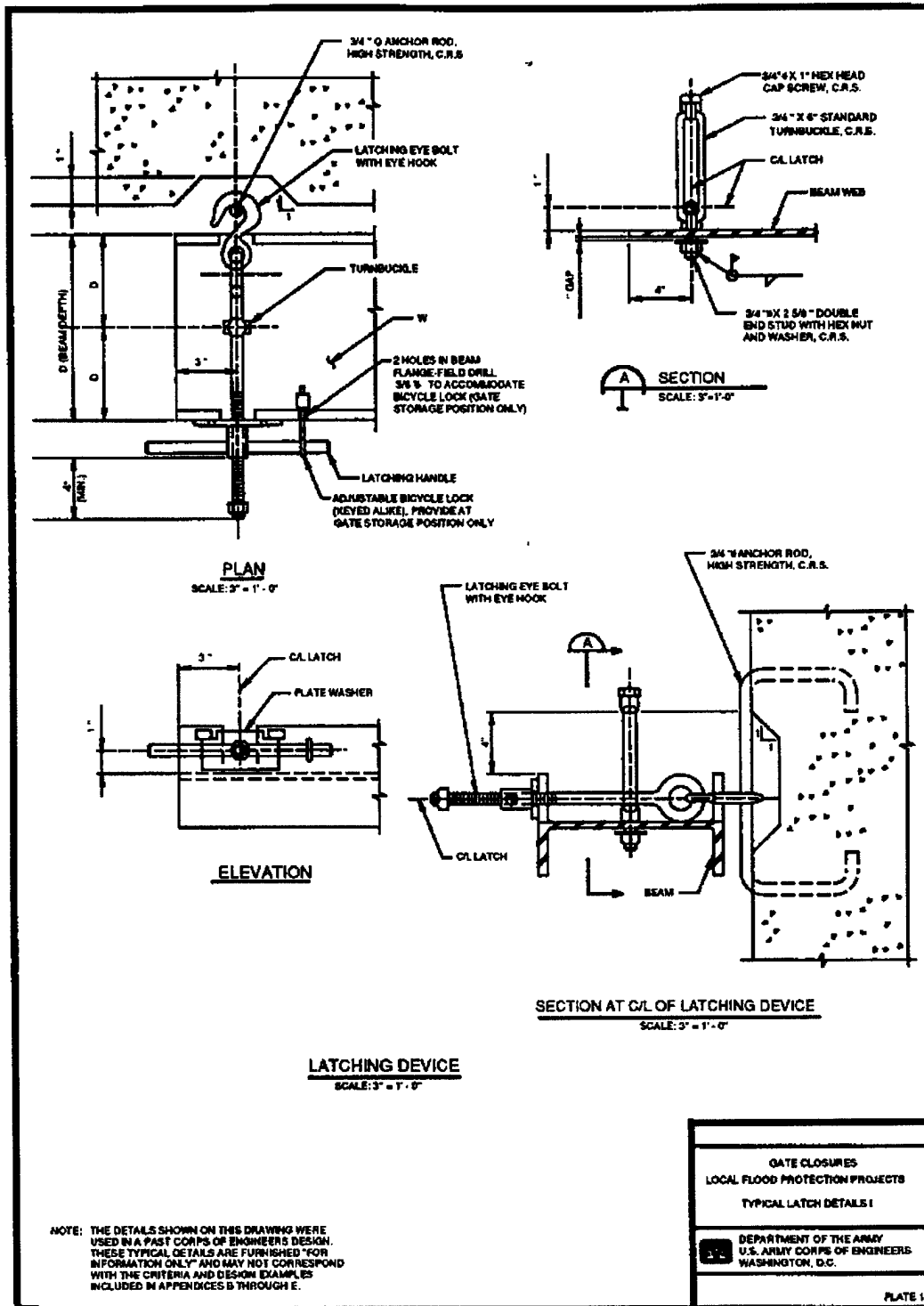

NOTE: THE DETAILS SHOWN ON THIS DRAWING WERE USED IN A PAST CORPS OF ENGINEERS DESIGN. THESE TYPICAL DETAILS ARE FURNISHED "FOR INFORMATION ONLY" AND MAY NOT CORRESPOND WITH THE CRITERIA AND DESIGN EXAMPLES INCLUDED IN APPENDICES B THROUGH E.

GATE CLOSURES	
LOCAL FLOOD PROTECTION PROJECTS	
TYPICAL LATCH DETAILS I	
	DEPARTMENT OF THE ARMY U.S. ARMY CORPS OF ENGINEERS WASHINGTON, D.C.
PLATE 11	

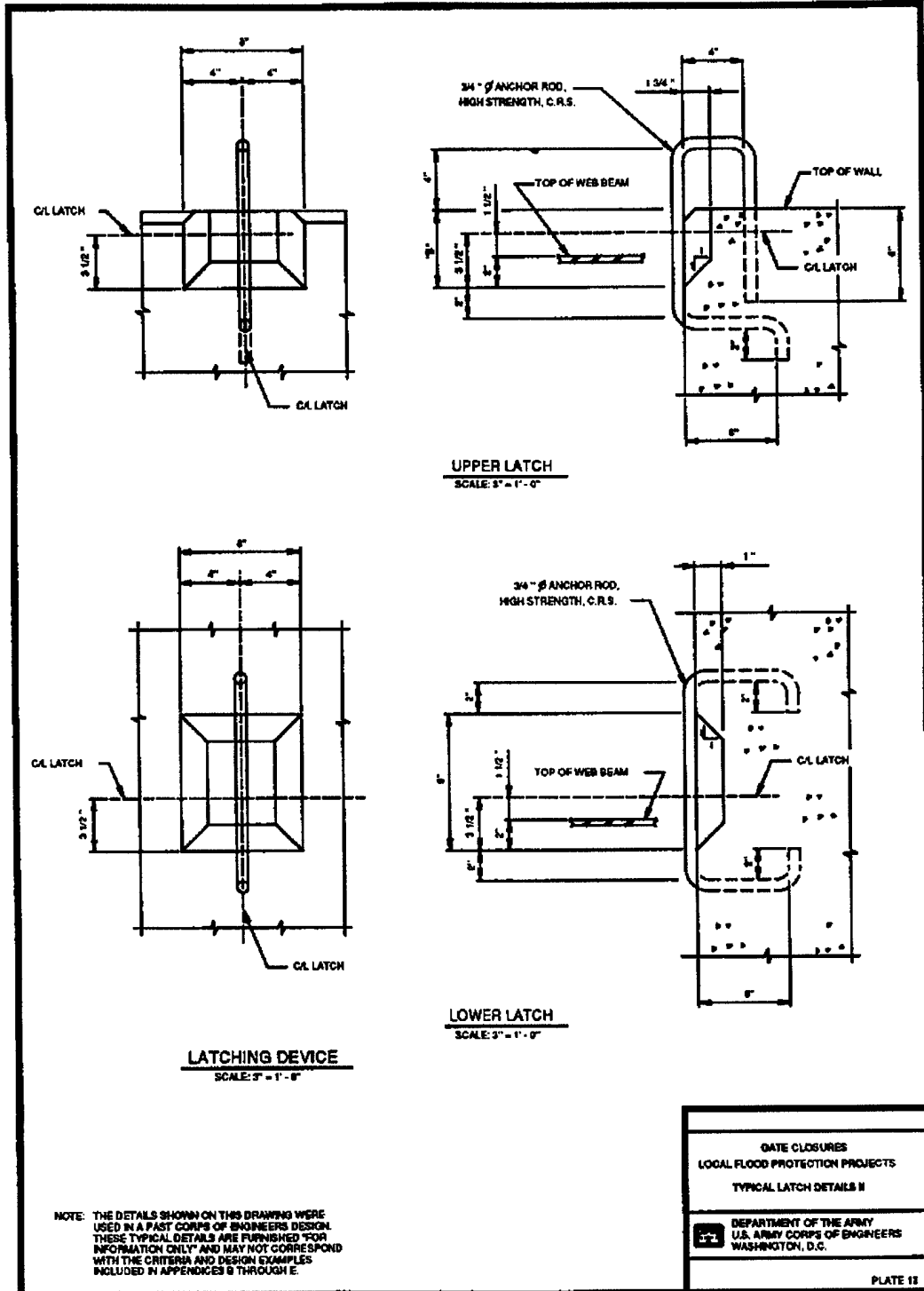

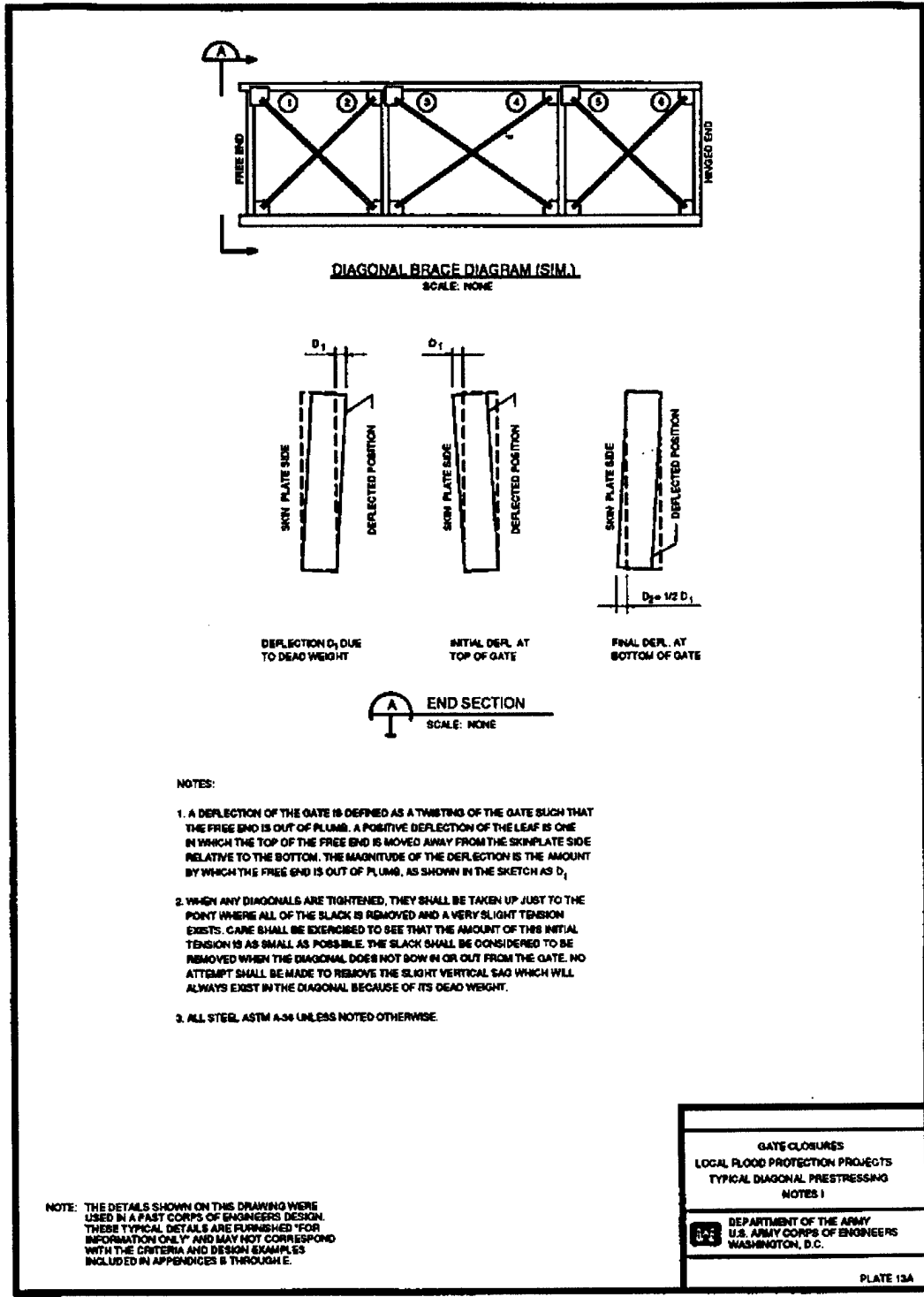

METHOD OF PRESTRESSING DIAGONALS

1. ENSURE THAT ALL DIAGONALS ARE SLACK.
2. LUBRICATE THE TURNBUCKLES ON THE DIAGONALS SO THEY CAN TURN EASILY.
3. ROSETTES FOR THE STRAIN GAGES SHALL BE PLACED ON ALL DIAGONALS A MINIMUM OF 20 HR BEFORE PRESTRESSING, UNLESS AN APPROVED QUICK-SETTING CEMENT IS USED.
4. WITHOUT THE RESTRAINT OF ANY GUYS OR JACKS, THE GATE WILL DEFLECT IN A POSITIVE DIRECTION UNDER ITS OWN DEAD WEIGHT. THIS DEFLECTION (D_1) SHALL BE MEASURED.
5. THE LEAF SHALL BE CLAMPED AT THE BOTTOM OF ITS FREE END, AND A JACKING OR PULLING DEVICE SHALL BE PLACED AT THE TOP OF THE FREE END.
6. MOVE THE FREE END TOWARD THE SKINPLATE SIDE UNTIL THE LEAF HAS A DEFLECTION IN A NEGATIVE DIRECTION EQUAL TO D_1 AT THE TOP.
7. HOLD THIS DEFLECTION AND TIGHTEN ALL OF THE DIAGONALS. THESE DIAGONALS SHALL BE TIGHTENED SO THAT THERE IS NO HORIZONTAL BOW. NO ATTEMPT WILL BE MADE TO REMOVE ALL OF THE VERTICAL SAG.
8. RESTRAIN THE TOP OF THE FREE END LEAF WITH GUYS.
9. PROCEED WITH THE JACKING AT THE BOTTOM OF THE FREE END UNTIL A DEFLECTION D_2 IS OBTAINED. DURING THIS OPERATION, THE ADJUSTMENT OF DIAGONALS 1, 3, AND 5 WILL NOT BE CHANGED. HOWEVER, TIGHTENING OF DIAGONALS 2, 4, AND 6 WILL BE CONTINUED UNTIL THERE IS A SLIGHT TENSION IN THE MEMBERS WHEN THE GATE IS IN ITS FINAL DEFLECTED POSITION.
10. DURING THE PRESTRESSING OPERATION, A STRAIN GAGE WILL BE USED TO DETERMINE THE STRESS IN THE DIAGONALS. THE MAXIMUM ALLOWABLE STRESS IN THE DIAGONALS DURING PRESTRESSING SHALL BE 20,000 PSI.
11. AFTER THE FINAL ADJUSTMENT OF THE DIAGONALS, THE GUYS AND JACKS WILL BE REMOVED AND THE GATE SHOULD RETURN TO A PLUMB POSITION. A DEFLECTION OF PLUS OR MINUS 1/8" WILL BE PERMITTED AT THE GATE'S FREE END.
12. FINAL STRESSES, UNLESS OTHERWISE APPROVED BY THE CONTRACTING OFFICER, SHALL BE 4,000 PSI MINIMUM AND 10,000 PSI MAXIMUM FOR ALL DIAGONALS.

NOTE: THE DETAILS SHOWN ON THIS DRAWING WERE USED IN A PAST CORPS OF ENGINEERS DESIGN. THESE TYPICAL DETAILS ARE FURNISHED "FOR INFORMATION ONLY" AND MAY NOT CORRESPOND WITH THE CRITERIA AND DESIGN EXAMPLES INCLUDED IN APPENDICES B THROUGH E.

GATE CLOSURES
LOCAL FLOOD PROTECTION PROJECTS
TYPICAL DIAGONAL PRESTRESSING
NOTES H

DEPARTMENT OF THE ARMY
U.S. ARMY CORPS OF ENGINEERS
WASHINGTON, D.C.

PLATE 13B

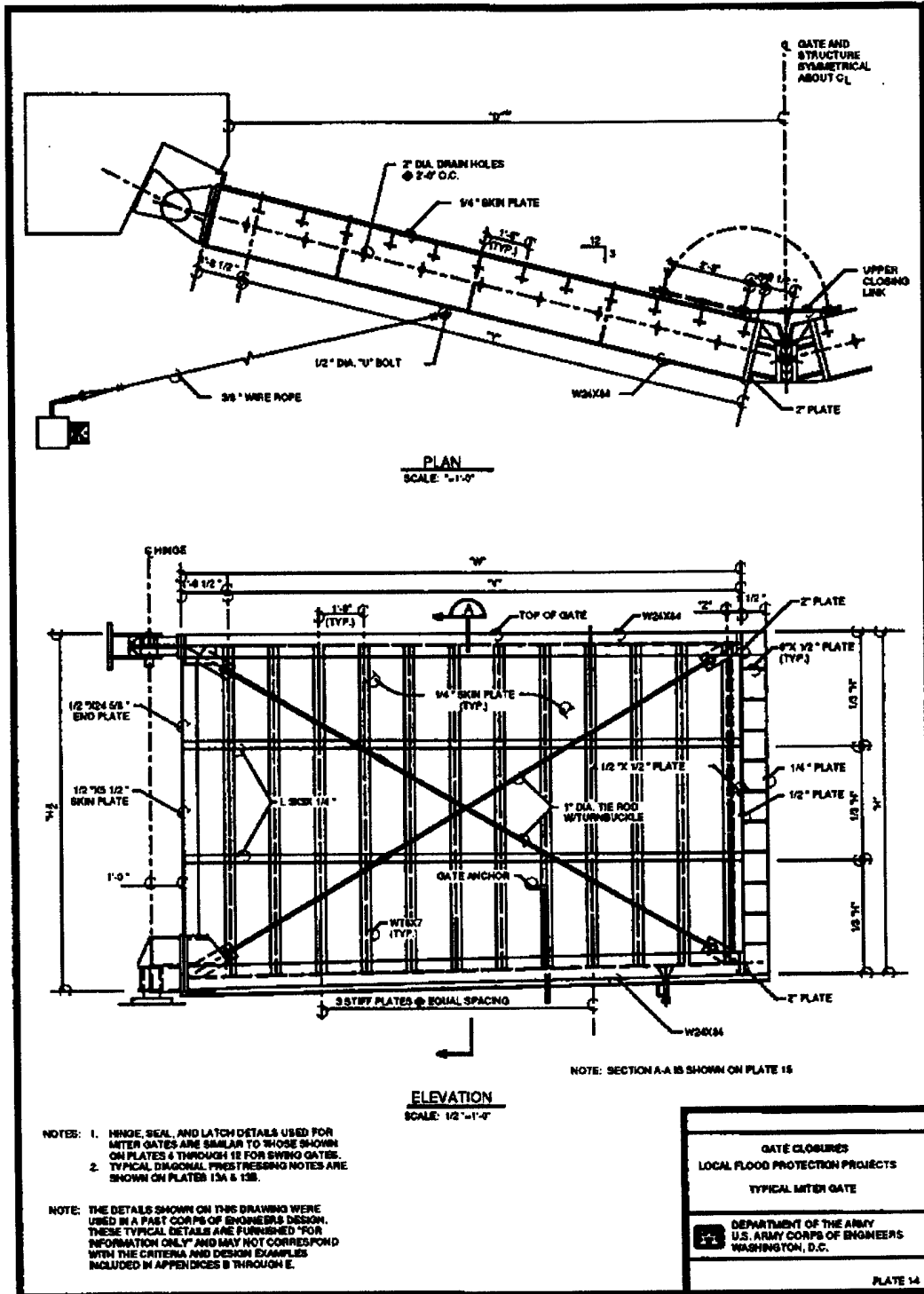

- NOTES: 1. HINGE, SEAL, AND LATCH DETAILS USED FOR MITER GATES ARE SIMILAR TO THOSE SHOWN ON PLATES 4 THROUGH 12 FOR SWING GATES.
2. TYPICAL DIAGONAL PRESTRESSING NOTES ARE SHOWN ON PLATES 13A & 13B.

NOTE: THE DETAILS SHOWN ON THIS DRAWING WERE USED IN A PAST CORPS OF ENGINEERS DESIGN. THESE TYPICAL DETAILS ARE FURNISHED FOR INFORMATION ONLY AND MAY NOT CORRESPOND WITH THE CRITERIA AND DESIGN EXAMPLES INCLUDED IN APPENDICES B THROUGH E.

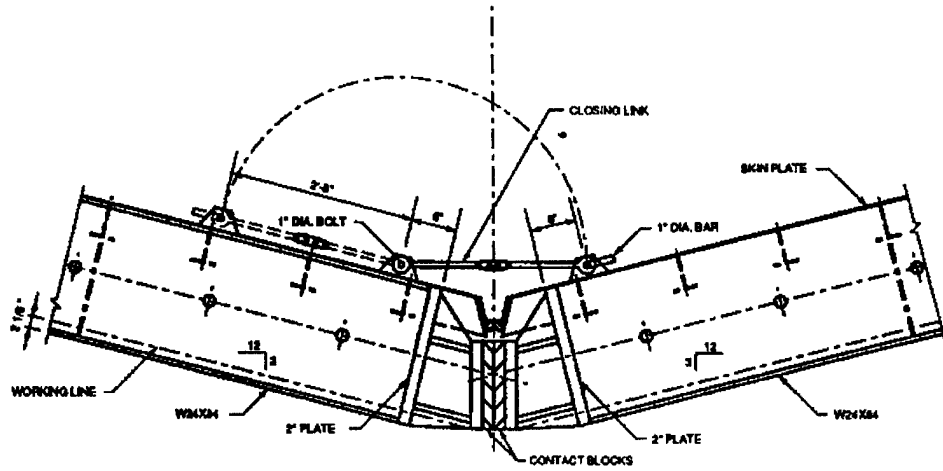

PLAN OF MITER DETAILS
SCALE: 1"=1'-0"

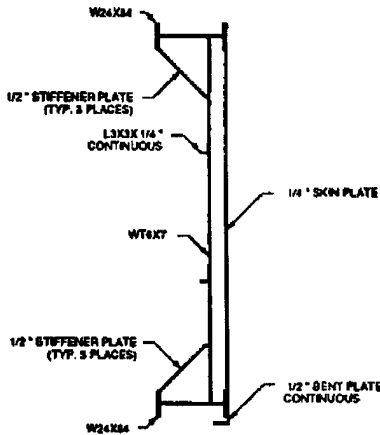

SECTION
SCALE: 1/2"=1'-0"

NOTE: THE DETAILS SHOWN ON THIS DRAWING WERE USED IN A PAST CORPS OF ENGINEERS DESIGN. THESE TYPICAL DETAILS ARE FURNISHED FOR INFORMATION ONLY AND MAY NOT CORRESPOND WITH THE CRITERIA AND DESIGN EXAMPLES INCLUDED IN APPENDICES B THROUGH E.

GATE CLOSURES LOCAL FLOOD PROTECTION PROJECTS TYPICAL MITER GATE DETAILS I	
	DEPARTMENT OF THE ARMY U.S. ARMY CORPS OF ENGINEERS WASHINGTON, D.C.
PLATE 15	

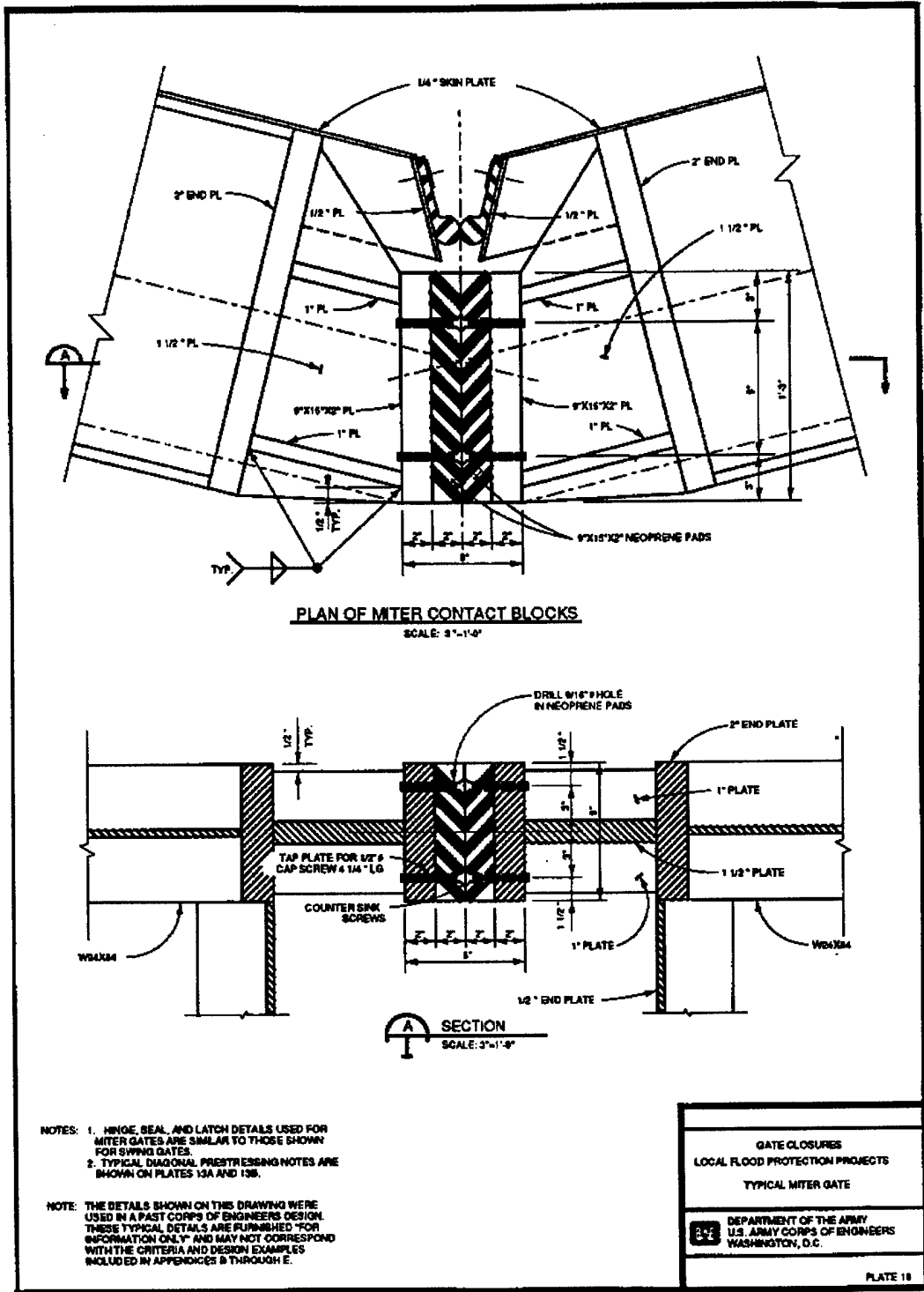

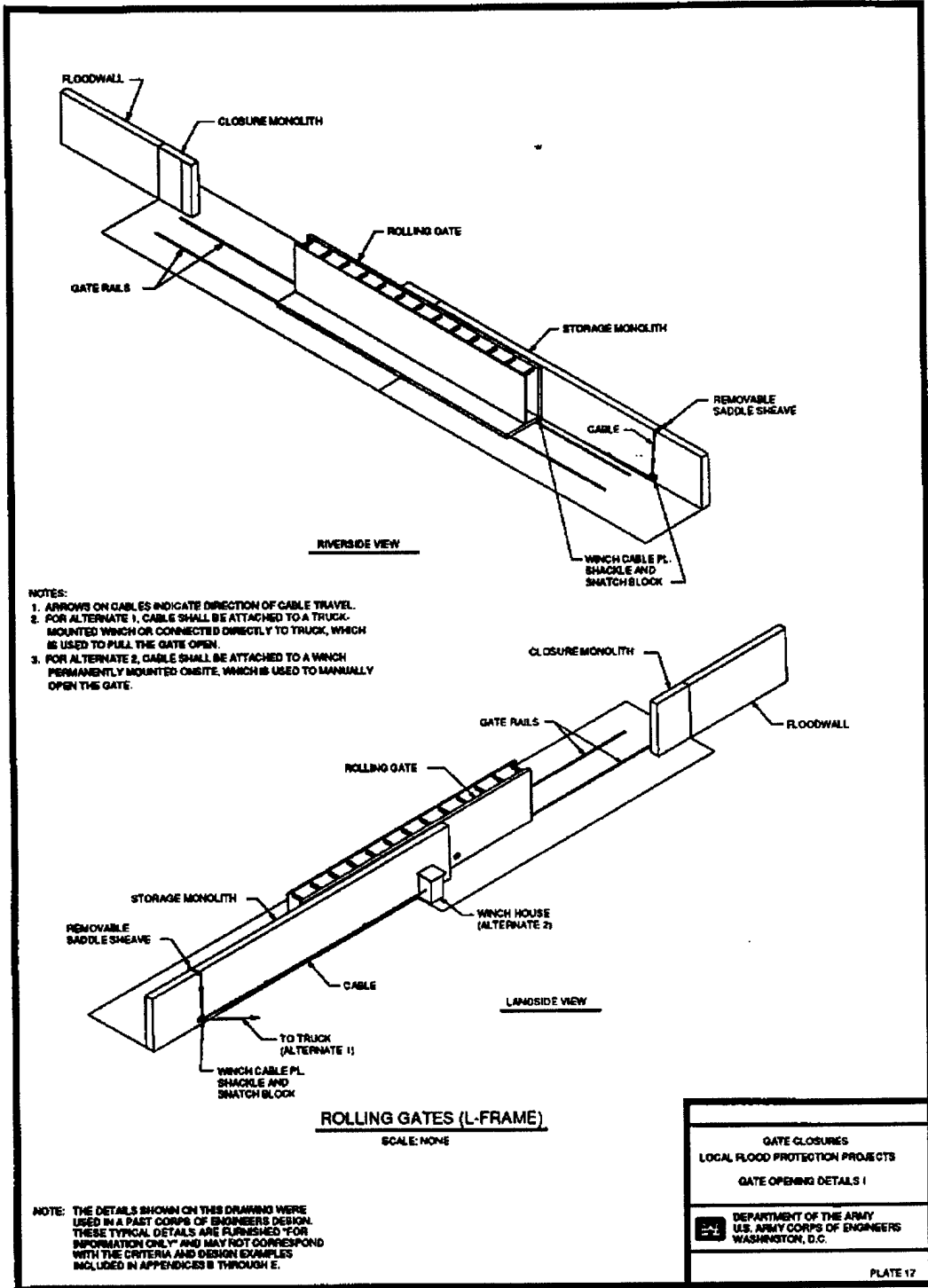

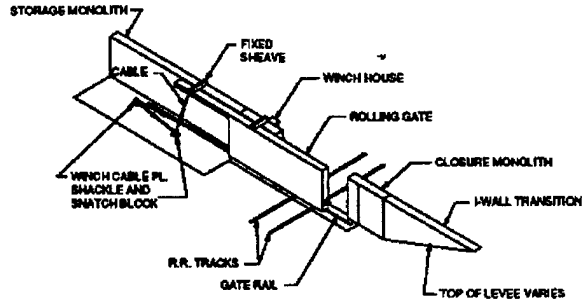

RIVERSIDE VIEW

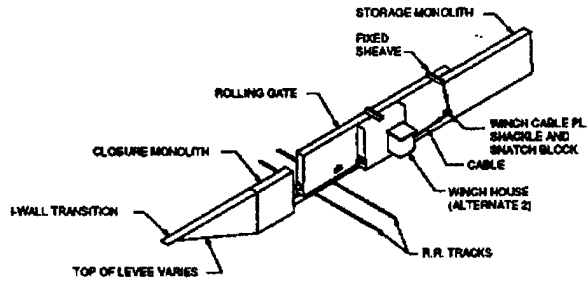

LANDSIDE VIEW

ROLLING GATE WITH STABILIZING TROLLEYS

SCALE: NONE

NOTES:

1. ARROWS ON CABLES INDICATE DIRECTION OF CABLE TRAVEL.
2. FOR ALTERNATE 1, CABLE SHALL BE ATTACHED TO A TRUCK MOUNTED WINCH OR CONNECTED DIRECTLY TO TRUCK, WHICH IS USED TO PULL THE GATE OPEN.
3. FOR ALTERNATE 2, CABLE SHALL BE ATTACHED TO A WINCH PERMANENTLY MOUNTED ON-SITE, WHICH IS USED TO MANUALLY OPEN THE GATE.

NOTE: THE DETAILS SHOWN ON THIS DRAWING WERE USED IN A PASTY CORPS OF ENGINEERS DESIGN. THESE TYPICAL DETAILS ARE FURNISHED FOR INFORMATION ONLY* AND MAY NOT CORRESPOND WITH THE CRITERIA AND DESIGN EXAMPLES INCLUDED IN APPENDICES B THROUGH E.

GATE CLOSURES LOCAL FLOOD PROTECTION PROJECTS GATE OPENING DETAILS II	
	DEPARTMENT OF THE ARMY U.S. ARMY CORPS OF ENGINEERS WASHINGTON, D.C.
PLATE 14	

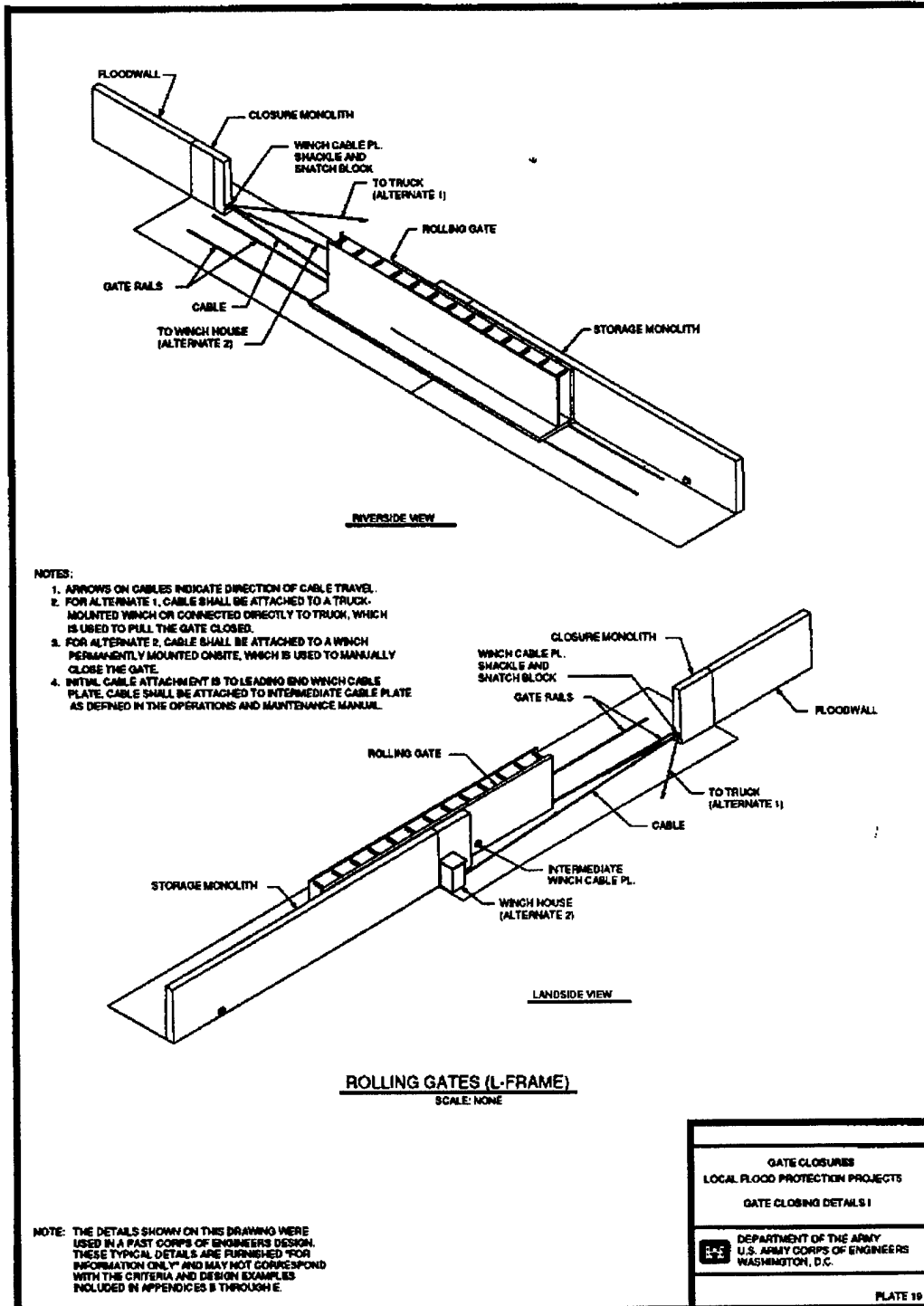

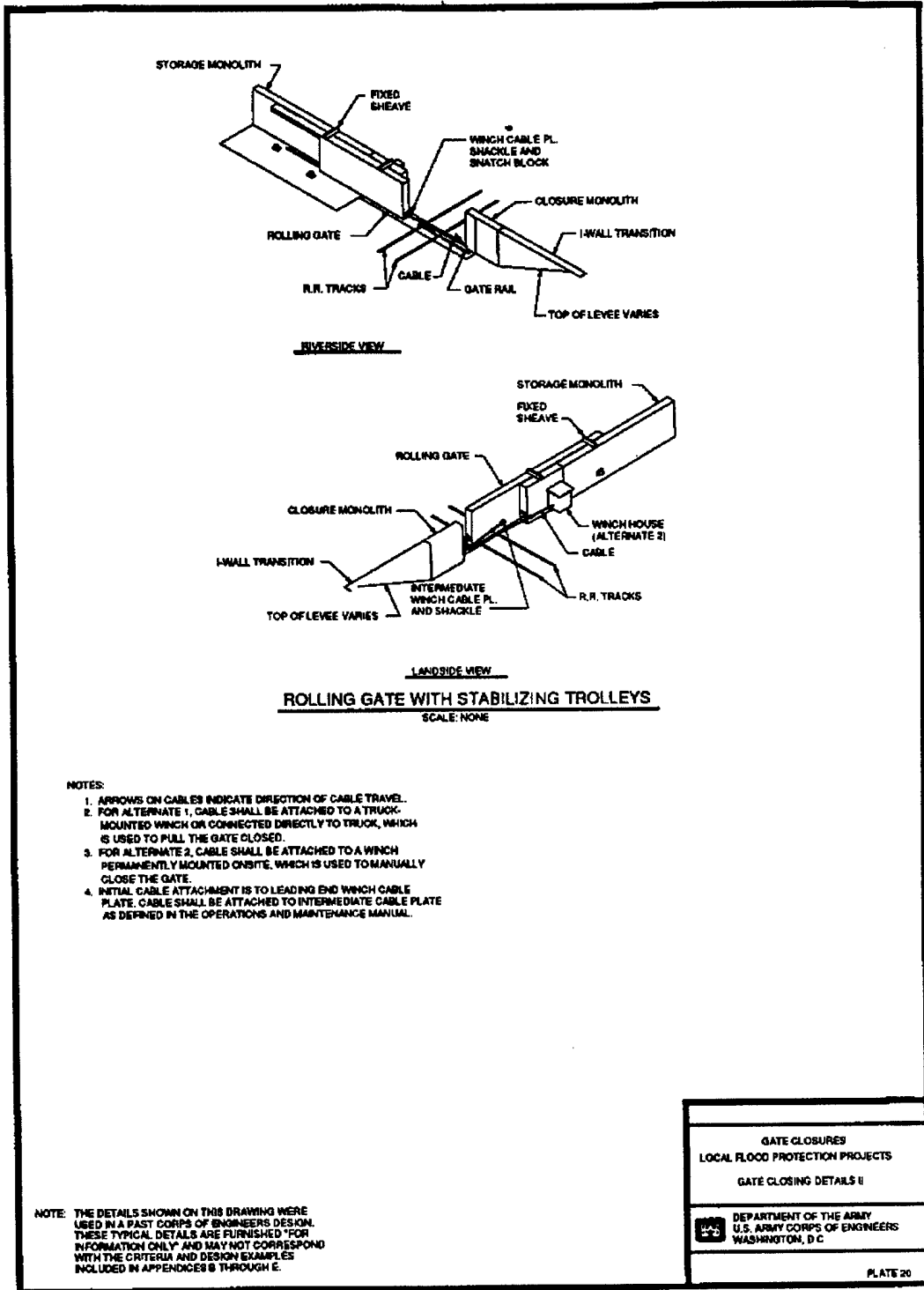

NOTES:

1. ARROWS ON CABLES INDICATE DIRECTION OF CABLE TRAVEL.
2. FOR ALTERNATE 1, CABLE SHALL BE ATTACHED TO A TRUCK-MOUNTED WINCH OR CONNECTED DIRECTLY TO TRUCK, WHICH IS USED TO PULL THE GATE CLOSED.
3. FOR ALTERNATE 2, CABLE SHALL BE ATTACHED TO A WINCH PERMANENTLY MOUNTED ON-SITE, WHICH IS USED TO MANUALLY CLOSE THE GATE.
4. INITIAL CABLE ATTACHMENT IS TO LEADING END WINCH CABLE PLATE. CABLE SHALL BE ATTACHED TO INTERMEDIATE CABLE PLATE AS DEFINED IN THE OPERATIONS AND MAINTENANCE MANUAL.

NOTE: THE DETAILS SHOWN ON THIS DRAWING WERE USED IN A PAST CORPS OF ENGINEERS DESIGN. THESE TYPICAL DETAILS ARE FURNISHED FOR INFORMATION ONLY AND MAY NOT CORRESPOND WITH THE CRITERIA AND DESIGN EXAMPLES INCLUDED IN APPENDICES B THROUGH E.

GATE CLOSURES LOCAL FLOOD PROTECTION PROJECTS GATE CLOSING DETAILS II
DEPARTMENT OF THE ARMY U.S. ARMY CORPS OF ENGINEERS WASHINGTON, D.C.
PLATE 20

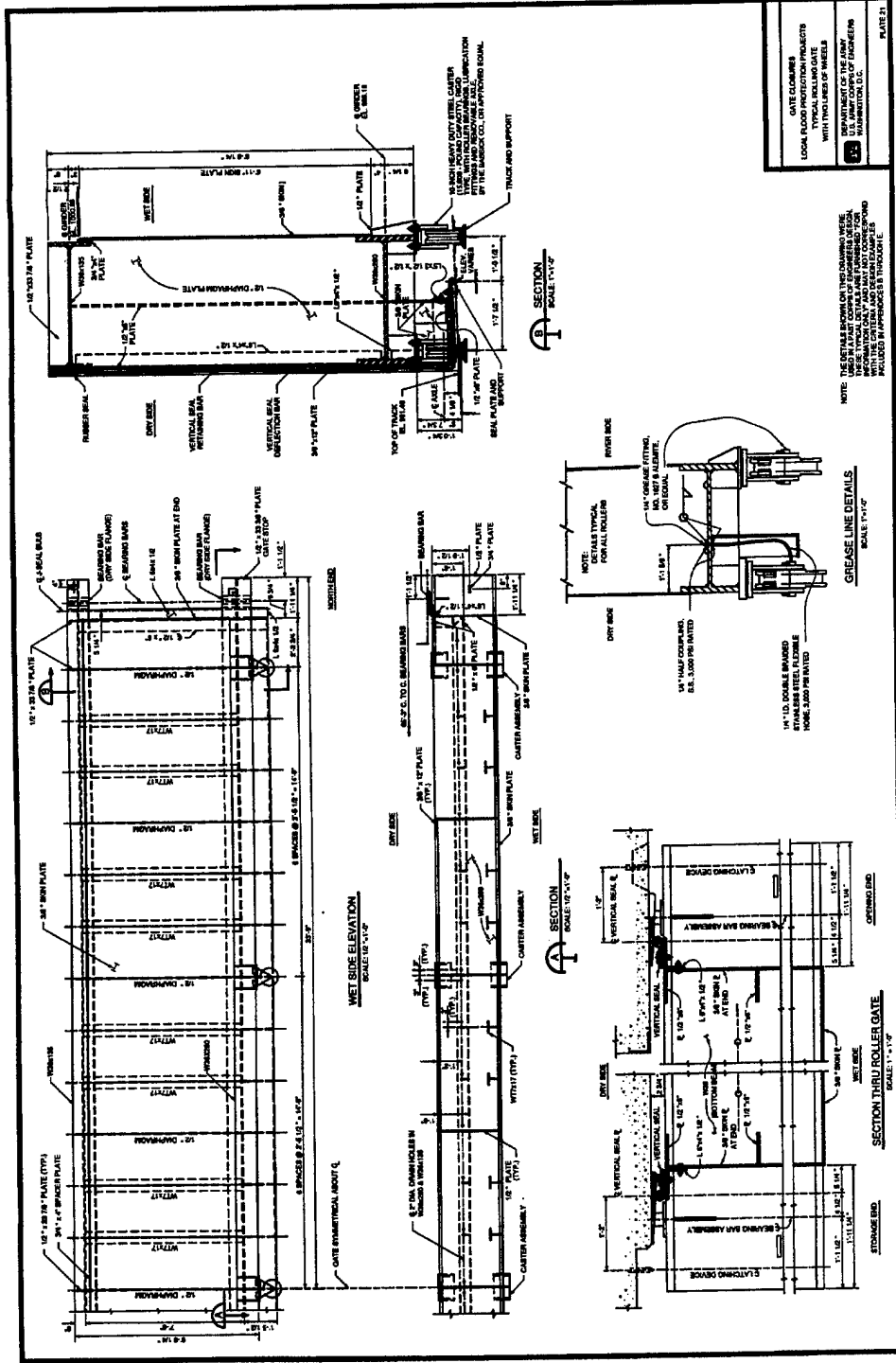
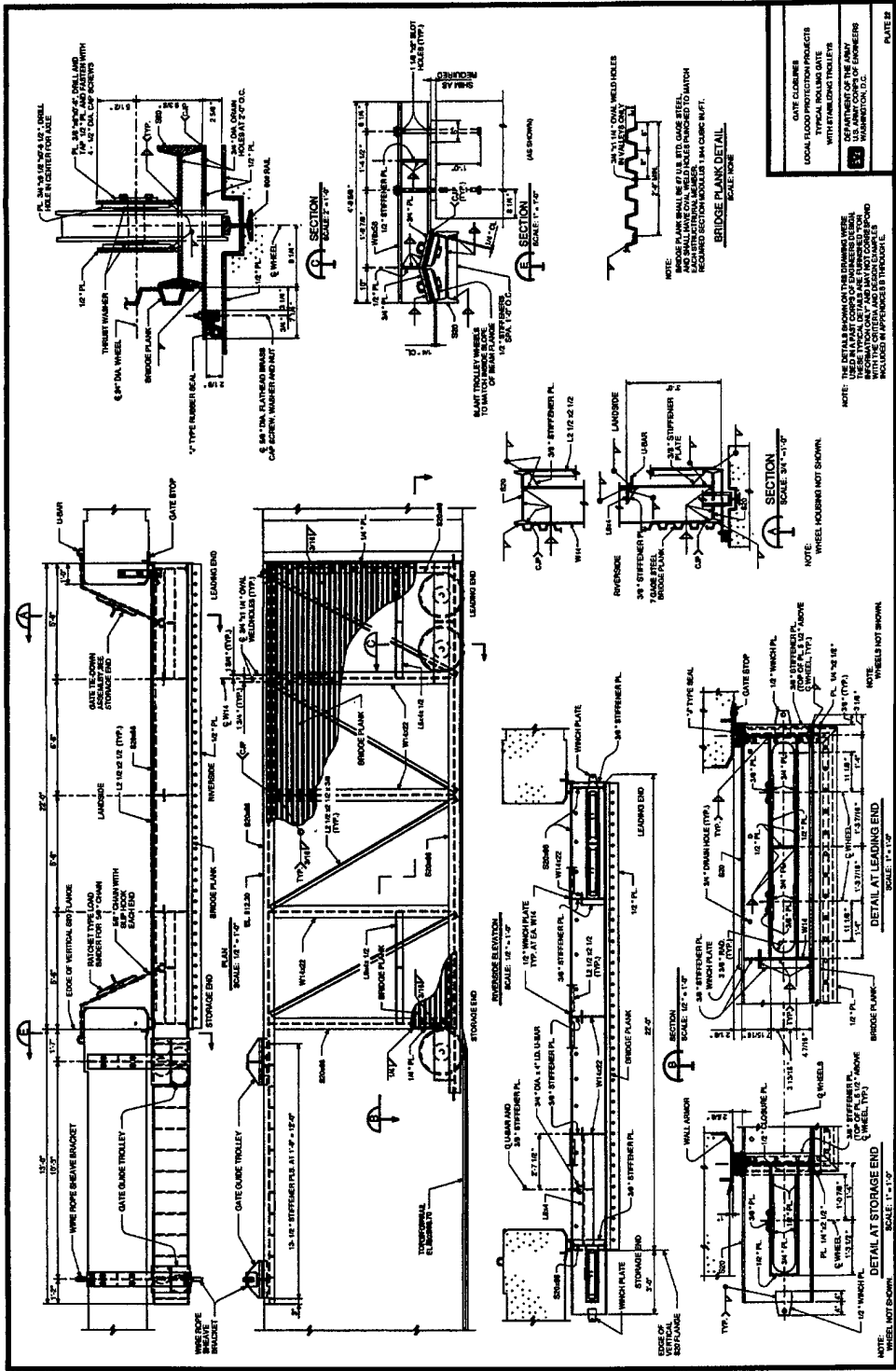
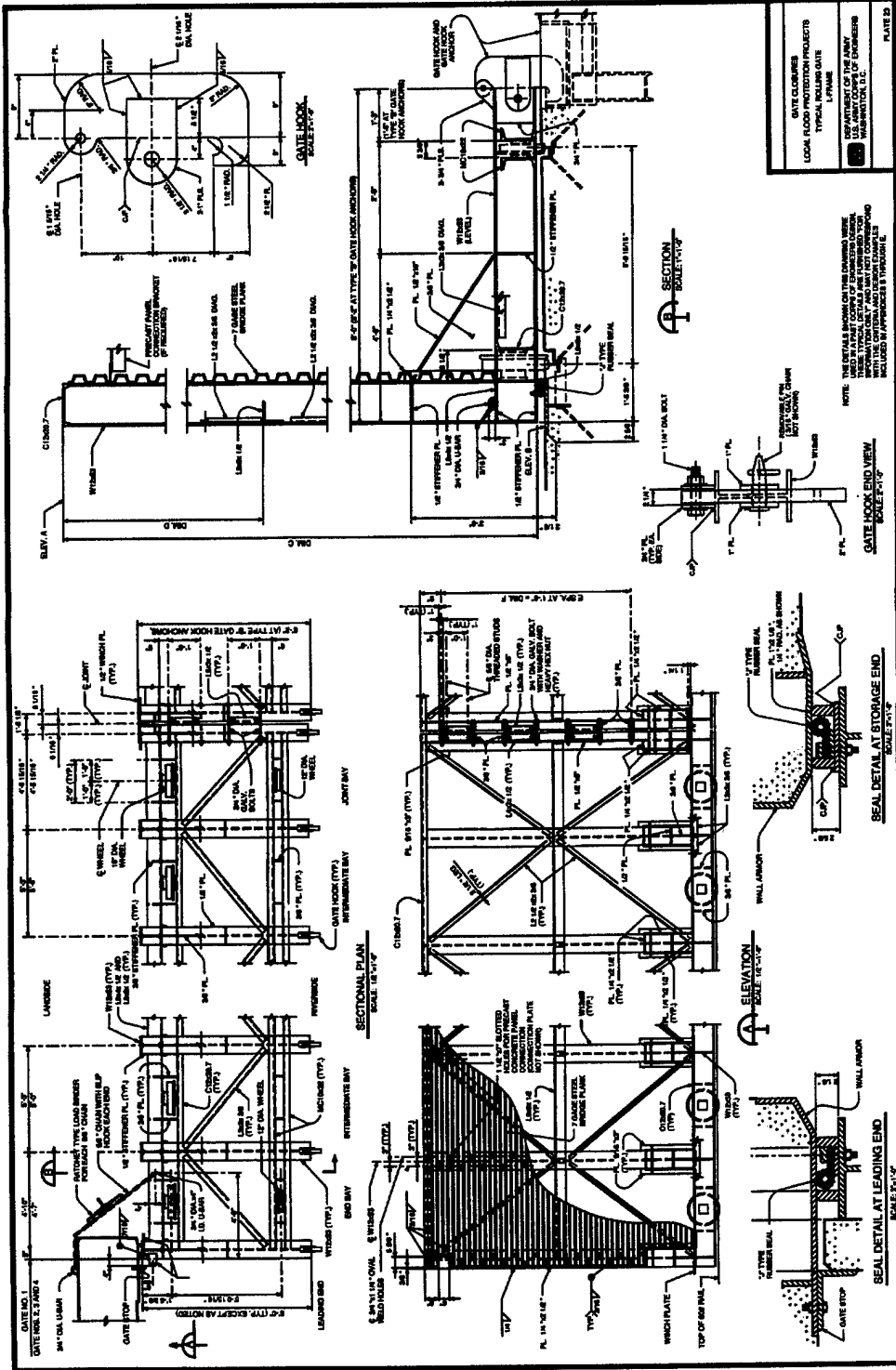

PLATE 21

GATE CLOSURES
LOCAL FLOOD PROTECTION PRODUCTS
WITH TWO LINES OF WHEELS
DESIGNED BY THE ARMY
U.S. ARMY CORPS OF ENGINEERS
WASHINGTON, D.C.

NOTE: DETAILS SHOWN ON THIS DRAWING WERE
USED IN A PAST CONTRACT AND WERE
APPROVED BY THE ARMY CORPS OF ENGINEERS.
THIS DRAWING IS A REISSUE OF THE
DRAWING ONLY AND SHALL BE CONSIDERED
VALID THROUGHOUT THE PROJECT.





Appendix A Checklist for Structural Design of Closure Structures

A-1. Reconnaissance Phase

a. Visit site with design team.

b. With project design engineer, determine general opening size.

c. With project design engineer, geotechnical engineer, hydraulic engineer, construction engineer, and operations engineer, assess potential alternatives using historical data and engineering judgment as to their practicality to construct, operate, and maintain.

(1) Ungated closure, sandbag closures, ramps, etc.

(2) Stoplog closure.

(3) Gated closure.

d. Identify structural engineering and design efforts and costs for the feasibility phase.

A-2. Feasibility Phase

a. Request foundation information from geotechnical engineer.

(1) Angle of internal friction.

(2) Cohesion.

(3) Adhesion.

(4) Unit weight of soil.

(5) Allowable bearing pressure.

(6) Modulus of subgrade reaction.

(7) Top of rock elevation.

(8) Groundwater elevation.

(9) Pile foundation data.

b. Determine design criteria, design assumptions, and load cases.

(1) EM 1110-2-2104.

(2) EM 1110-2-2105.

(3) EM 1110-2-2703.

(4) EM 1110-2-2502.

(5) EM 1110-2-2906.

c. With project design engineer, refine opening dimensions.

(1) Reduce width to minimum.

(2) Raise sill elevation as high as possible.

(3) Determine sill and approach slab geometry.

(4) Determine overhead clearance.

(5) Determine sight distance and geometry.

(6) Determine requirements for sidewalks and guardrails.

d. With project design engineer, assess alternatives and propose best alternative.

(1) Stoplogs.

(2) Panels.

(3) Miter gate.

(4) Overhead trolley gate.

(5) Swing gate.

(6) Roller gate.

(7) Double gate.

(8) Other gate.

e. Prepare preliminary design to the level necessary to prepare a baseline cost estimate. Present design to project engineer to be given to cost engineer.

(1) Design main structural members.

(2) Size abutments and sill and perform stability analysis.

31 Mar 94

(3) Prepare preliminary pile design if needed.

(4) Prepare quantities.

f. Identify structural engineering and design efforts and costs for preparing design memorandum (DM) and/or plans and specifications (P&S).

g. With engineers from other Engineering Division elements and Construction Division, establish design and construction schedule.

h. Provide input for feasibility report to project engineer.

(1) Technical basis for selection of gate and abutments including general configuration, material, and foundation.

(2) Criteria and assumptions.

(3) Design computations.

(4) Brief description of any additional special analyses required for DM and/or P&S.

A-3. Design Memorandum

a. Review design criteria, design assumptions, and load cases.

(1) EM 1110-2-2104.

(2) EM 1110-2-2105.

(3) EM 1110-2-2502.

(4) EM 1110-2-2703.

(5) EM 1110-2-2906.

b. Continue design.

(1) Refine sill configuration.

(2) Design secondary structural members.

(3) Refine foundation pile design.

(4) Design reinforcing steel for abutments and sill.

(5) Design other appurtenances.

(6) Coordinate design with Safety and Security offices.

(7) Verify availability of materials.

(8) Check criteria, assumptions, and computations.

c. Provide input for design memorandum to project engineer.

(1) List basic data and criteria used.

(2) Prepare computations to determine use, adequacy, shape, and stability of critical sections.

(3) Participate in value engineering studies.

A-4. Plans and Specifications

a. Complete design.

(1) Design details.

(2) Refine and verify dimensional details.

(3) Complete drawings.

(4) Provide technical input for specifications.

(5) Prepare quantities and submit to project engineer to be forwarded to cost engineer.

(6) Check computations, plans, specifications, and quantities.

(7) Revise in accordance with review comments.

b. Participate in value engineering studies.

c. Provide technical assistance to other members of design team as requested.

A-5. Construction Phase

a. Review shop drawings.

b. Make site visits as scheduled and required.

c. Provide assistance in Requests for Information, claims, and modifications when requested.

d. Provide input into operation and maintenance manual.

e. Prepare as-built drawings.

A-6. Operations Phase

Depending on Local Cooperative Agreement and project purpose:

a. Participate in periodic inspections.

b. Modify as-built drawings.

c. Review operational drawings.

d. Correct project deficiencies as required.

e. Evaluate and design replacement features as required.

Appendix B Stoplog Design Examples

The opening for the closure in this example is 47 ft, 4 in. wide by 4 ft, 4 in. high. The closure will be designed using aluminum stoplogs (Example B.1.a.) and steel stoplogs (Example B.1.b.).

Load Cases:

The load cases given in EM 1110-2-2502 for inland floodwalls were taken into consideration. The only significant case for design was found to be case I2.

Case I2, Maximum Flood Loading. Stoplogs are in place, water on the unprotected side is at top of closure, water on protected side is at or below the top of sill. Design stresses for aluminum shall not exceed 1.11 times the allowable stresses given in Aluminum Association, Inc. (1986). Design stresses for steel shall not exceed 1.11 times the allowable stresses given in AISC (1989).

The stoplogs are designed as simple beams spanning the openings between posts and the openings between walls and posts. Intermediate posts are designed as cantilever beams fixed at the sill.

EXAMPLE B.1.a.(ALUMINUM).

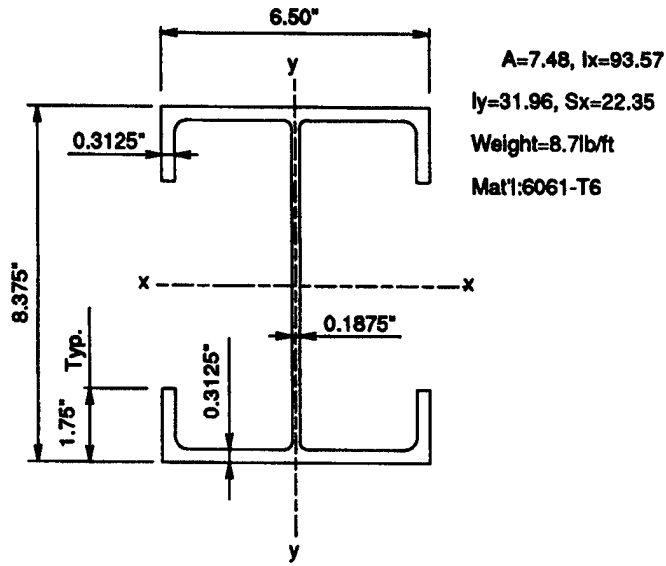

STOPLOG SECTION

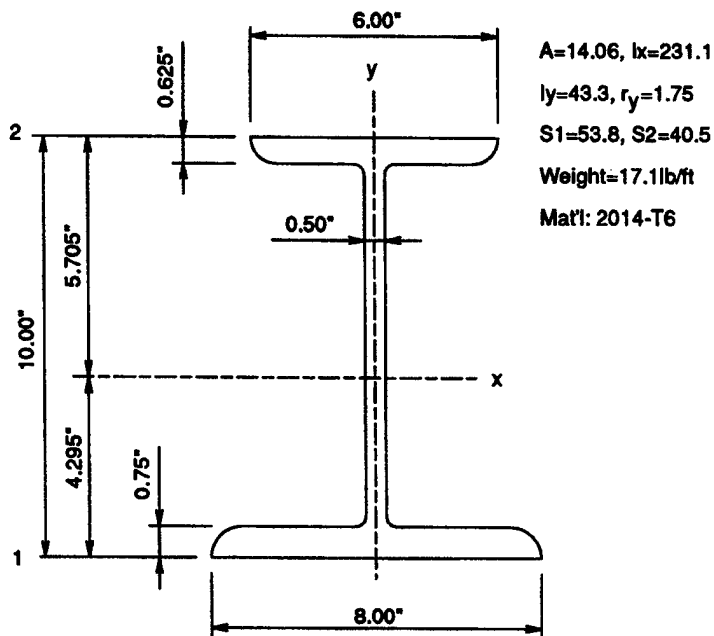

POST SECTION

EXAMPLE B.1.a.(ALUMINUM)

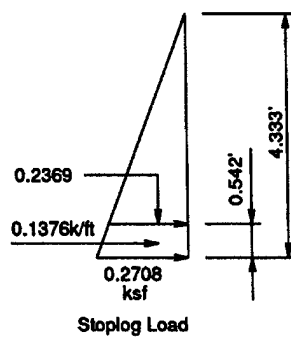

STOPLOG:

$W=0.1376\text{k/ft}$, $L=\text{Post Spacing}=12.00'$

$M=WL^2/8=2.477\text{k-ft}=29.724\text{k-in}$

$V=WL/2=0.1376 \times 12/2=0.826\text{k}$

All Specifications Listed Below Are From
Table 3.3.27 Of Aluminum Association, Inc. (1986).

Specification 1: Flexural Tension Allowable=19.00ksi
(Nonwelded Member)

Note: The Allowable Stress For Welded Aluminum
Is About 50% Less Than The Nonwelded Member

Specification 15: Compression In Flange Lips.

$b/t=(1.75-0.3125)/0.3125=4.6 < 6.8$, $F_{bc}=21\text{ksi}$

Specification 16: Compression In Flange, Both Edges Supported.

$b_L=1.75-0.3125=1.4375"$, $b_f=(6.5-2 \times 0.3125-0.1875)/2=2.844"$

$b_f/3=0.948" < b_L$ o.k.

$b_f/t=2.844/0.3125=9.1 < 21$, $F_{bc}=21\text{ksi}$

Specification 18: Compression In Web.

$h/t=(8.375-2 \times 0.3125)/0.1875=41.33 < 46$, $F_{bc}=28\text{ksi}$

$f_b=M/S_x=29.724/22.35=1.33\text{ksi}$, $F_b=1.11 \times 19=21.09\text{ksi} > f_b$ o.k.

$f_s=0.826/(8.375 \times 0.18375)=0.526\text{ksi}$ Shear Is Negligible.

THIS STOPLOG SECTION PROVIDES AN OVERDESIGN. HOWEVER, IT IS AVAILABLE FROM THE USING AGENCY'S INVENTORY AND CAN BE EASILY INSTALLED BY MANUAL LABOR. IT WILL BE USED.

EXAMPLE B.1.a.(ALUMINUM)

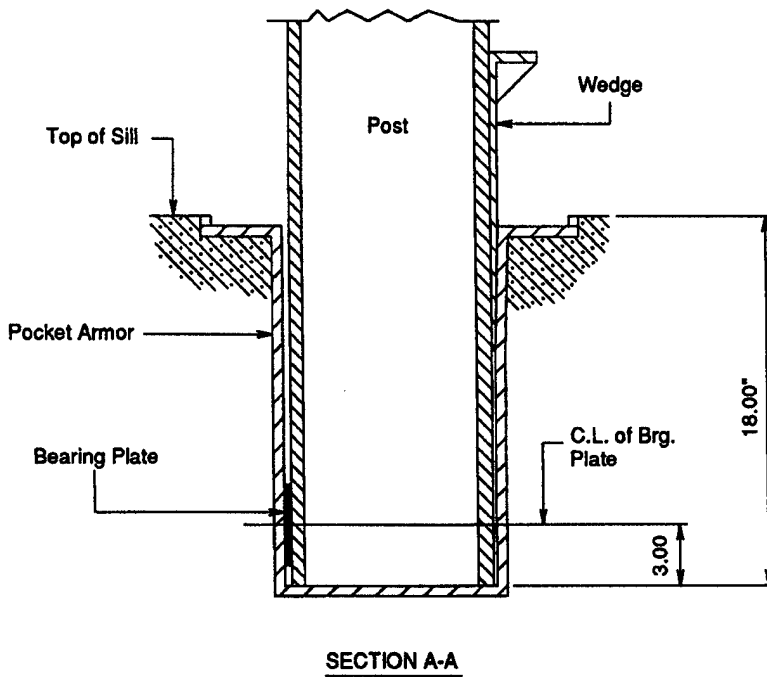
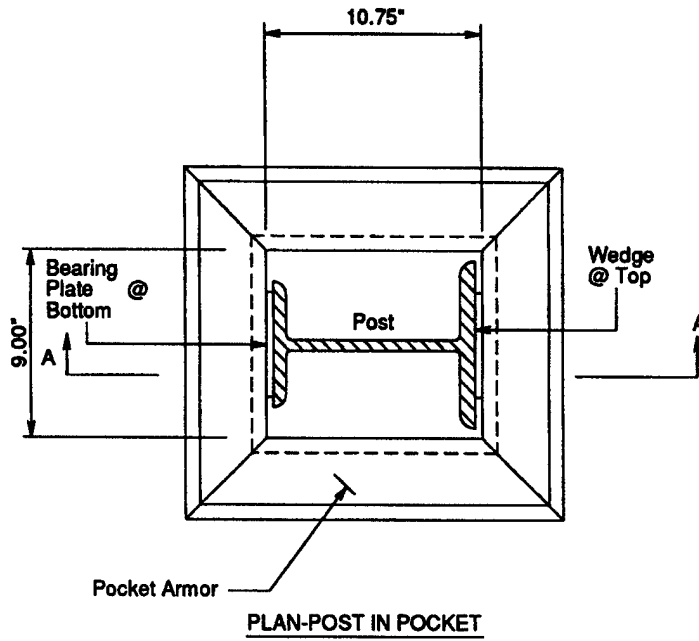

EXAMPLE B.1.a.(ALUMINUM)

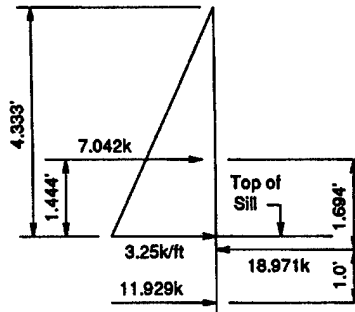

INTERMEDIATE POST:

$$M=7.042 \times 1.694=11.93 \text{ k-ft}=143.16 \text{ k-in}$$

$$V=11.929 \text{ k}$$

All Specifications Listed Below Are From
Table 3.3.8 of Aluminum Association, Inc. (1986).

POST LOADING

Specification 1: Flexural Tension Allowable=25ksi

Specification 11: Flexural Compression.

$$L_b=4.333+1.25=5.583'=67", L_b/t_y=67/1.75=38>19$$

$$F_{bc}=36.3-0.23 \times 38=27.56 \text{ ksi}$$

Specification 18: Compression in Web.

$$h=10", t_w=0.50", h/t_w=20<43, F_{bw}=41 \text{ ksi}$$

Specification 20: Web Shear.

$$h/t_w=20<32, F_s=19 \text{ ksi}$$

$$f_b=M/S_2=143.16/40.5=3.53 \text{ ksi}, F_b=1.11 \times 25=27.75 \text{ ksi} > f_b \text{ o.k.}$$

$$f_s=11.929/(10 \times 0.5)=2.386 \text{ ksi}, F_s=1.11 \times 19=21.09 \text{ ksi} > f_s \text{ o.k.}$$

THIS POST SECTION PROVIDES AN OVERDESIGN. HOWEVER, IT IS AVAILABLE FROM THE USING AGENCY'S INVENTORY AND CAN BE EASILY INSTALLED BY HAND. IT WILL BE USED.

EXAMPLE B.1.a. (ALUMINUM)

STOPLOG DEFLECTION:

$$\triangle = 5WL^4 / 384EI, W=0.1376/12=0.011467\text{k/in}, E=10800\text{ksi}$$

$$I=93.57, \triangle = 5 \times 0.011467(12 \times 12)^4 / (384 \times 10800 \times 93.57) = 0.064''$$

$$\triangle / L = 1/2250 < 1/200 \text{ o.k.}$$

POST DEFLECTION:

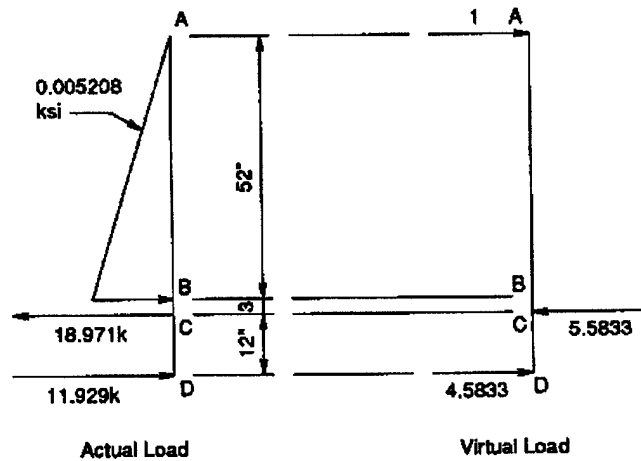

M= Moment Due To Actual Load m= Moment Due To Virtual Load

$$\triangle A = \sum \int M m d y / EI$$

From A To B: $M=0.000868y^3, m=y, Mm=0.000868y^4$

$$\int_0^{52} M m d y = 66003$$

From D To C: $M=11.929y, m=4.5833y, Mm=54.6742y^2$

$$\int_0^{12} M m d y = 31493$$

From C To B: $M=143.148-7.042y, m=55-y$

$$Mm=7873.14-530.458y+7.042y^2$$

$$\int_0^3 M m d y = 21296$$

$$\triangle A = (66003+31493+21296)/(10800 \times 231.1) = 0.048'' \quad \triangle / L = 1/1396 \text{ o.k.}$$

EXAMPLE B.1.b. (A36 STEEL)

All Equation Numbers In Parentheses Are
From The Specification In AISC (1989)

STOPLOG:

Trial Section S4x7.7, $I_x=6.08$, $S_x=3.04$, $b_f=2.663$ in = 0.2219'

W =Load On Bottom Log= $0.5[2 \times 0.2708 - 0.0625 \times 0.2219](0.2219)$

$W=0.0586$ k/ft, $M=0.0586(12)^2/8=1.055$ k-ft = 12.66 k-in

$f_b=M/S_x=12.66/3.04=4.164$ ksi

$F_b=0.66F_y=24$ ksi (F1-1)

$\Delta=5(0.0586/12)(12 \times 12)^4 / (384 \times 29000 \times 6.08)=0.155$ in

$\Delta/L=1/929 < 1/200$ o.k.

INTERMEDIATE POST:

Post Pocket Details Will Be Similar To Those

Used In Example B.1.a.

Trial Section W8x10, $I_x=30.8$, $S_x=7.81$, $b_f=4$ in, $r_T=0.99$

$L_b=67$ in, $L_c=76 \times 4/6=50.67 < 67$ (F1-2)

$L_b/r_T=67/0.99=68$

$F_b=[2/3 - 36(68)^2 / (1530 \times 10^3)] \times 36=20.08$ ksi (F1-6)

$M=143.16$ k-in (Same As Example B.1.a.)

$f_b=M/S_x=143.16/7.81=18.33$ ksi

$1.11F_b=22.31$ ksi $> f_b$ o.k.

Δ (From Example B.1.a.) = 0.048 in

Δ (For Steel Post) = $0.048(10800/29000)(231.1/30.8)=0.134$ in

$\Delta/L=0.134/67=1/500 < 1/200$ o.k.

USE S4x7.7 STOPLOGS AND W8x10 POSTS

Appendix C Swing Gate Design Example

The opening for the closure in this example is 29.50 ft wide by 12.30 ft high.

Load Cases:

In accordance with EM 1110-2-2502, consideration shall be given to load cases I1 through I4. An additional case for the gate in any position, subjected to dead load only, is added for checking hinge design.

Case I1, Design Flood Loading. Gate is closed; water on the unprotected side is at the design flood elevation; water is at or below sill surface on protected side. Design stresses shall not be greater than 5/6 of stresses allowed in AISC (1989).

Case I2, Maximum Flood Loading. Same as case I1 except that water level is to top of gate on unprotected side. Design stresses shall not be greater than 1.11 times the stresses allowed in AISC (1989).

Case I3, Earthquake Loading. Water is at usual level (non-flood condition) on unprotected side; earthquake-induced forces are acting. (Note: This case is applicable to support structures only).

Case I4, Short-Duration Loading. Gate is either open, closed, or in between and is subjected to construction and/or wind loads. Design stresses shall not be greater than 1.11 times the stresses allowed in AISC (1989).

Case I5, Gate Swinging. Gate in any position, subjected to dead load only. Design stresses shall not be greater than 5/6 of stresses allowed in AISC (1989).

In this example, cases I1 and I3 are not significant and skin plate, intercostals, and girders are designed for case I2 with design stresses not greater than 1.11 times stresses allowed in AISC (1989). Case I4 is applicable for design of latching devices. Case I5 is applicable to hinge design.

The skin plate is designed as a fixed end beam, spanning between intercostals. In order to ensure that the flat plate theory is applicable, deflection will be limited to 0.4 of thickness.

The intercostals are designed as simple beams spanning between girders.

Girders are designed as simple beams, spanning between hinges on one side and wall bearings on the other side of the opening.

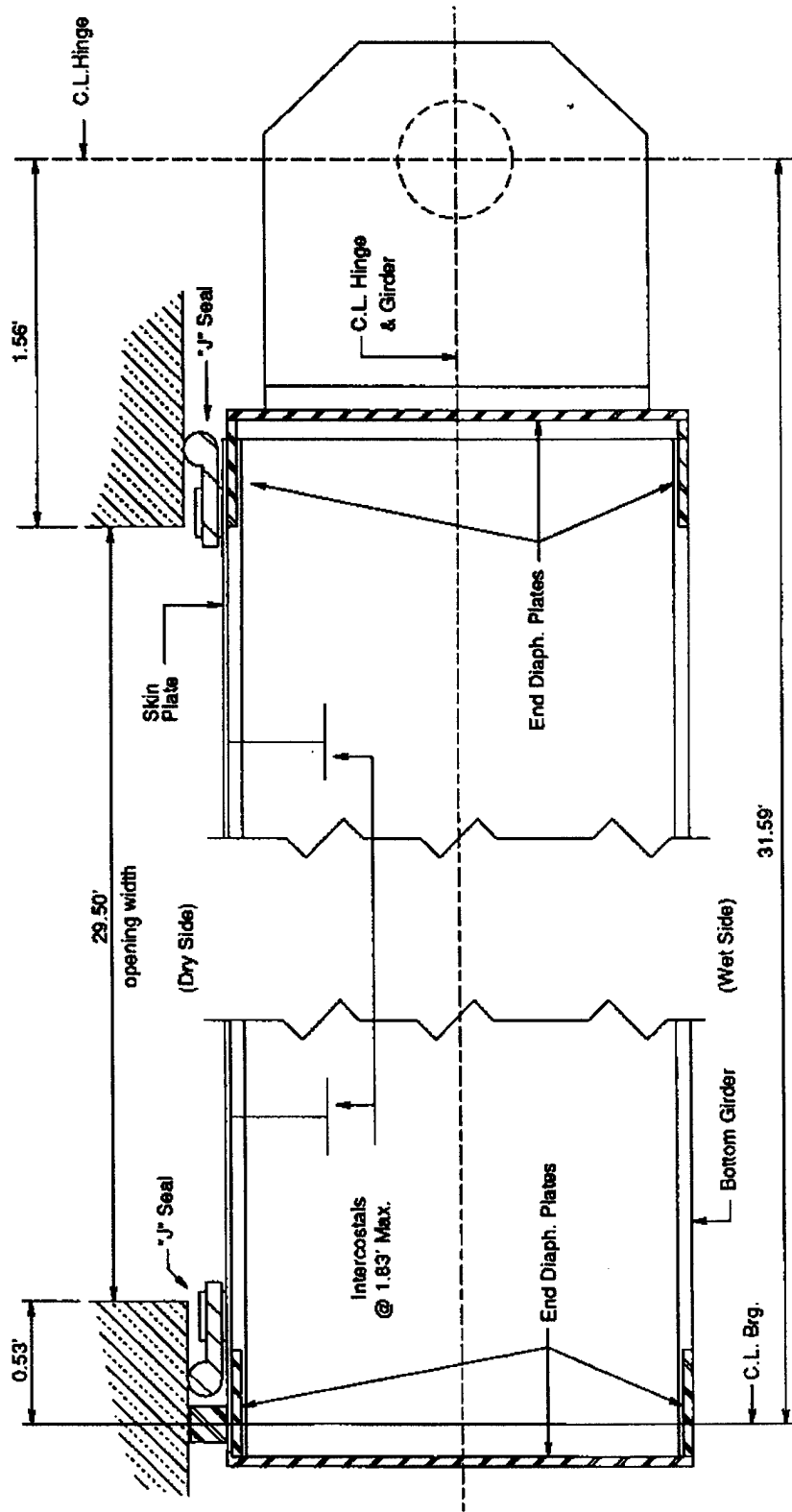

HORIZONTAL SECTION THRU GATE

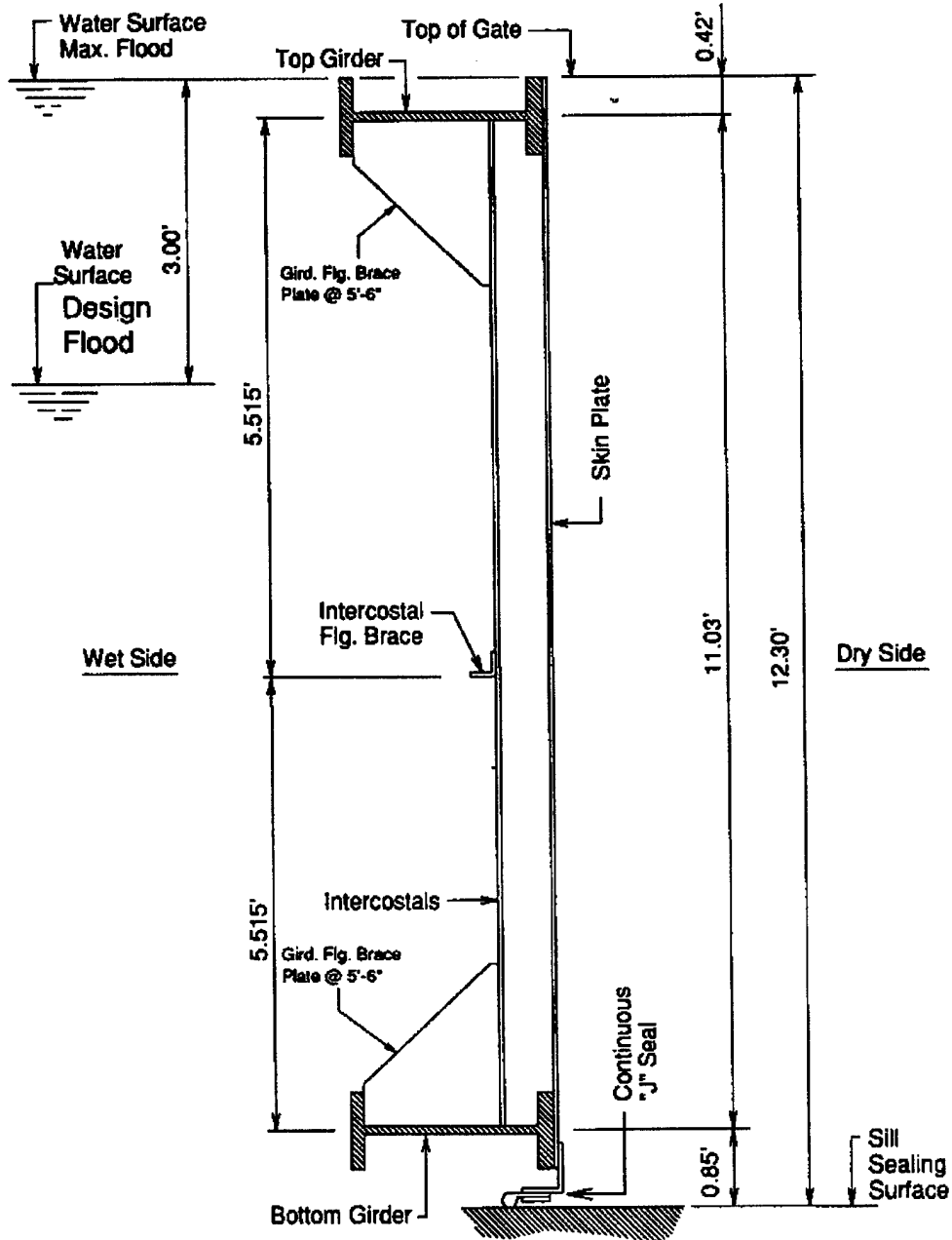

VERTICAL SECTION THRU GATE

SKIN PLATE DESIGN; LOAD CASE I2

(Material: A36 Steel)

Assuming a 9" flange for the bottom girder, the hydrostatic pressure 6" above the flange is:

$$p = 0.0625(12.3 - 0.85 - 0.375 - 0.5) = 0.6609 \text{ ksf} = 0.00459 \text{ ksi}$$

$$M = pb^2/12 = 0.00459(22)^2/12 = 0.1851 \text{ k-in}$$

$$F_b = 1.11 \times 0.75 F_y = 1.11 \times 0.75 \times 36 = 30 \text{ ksi}$$

$$t_{\text{min-stress}} = (pb^2/2F_b)^{1/2}$$

$$t_{\text{min-stress}} = [0.00459(22)^2/(2 \times 30)]^{1/2} = 0.1924"$$

$$\text{defl.} = pb^4/384EI; E = 29000, l = t^3/12, \text{defl.} = 0.4t$$

$$0.4t = 12pb^4/384Et, t^3 = pb^4/12.8E$$

$$t_{\text{min-defl.}} = [0.00459(22)^4/(12.8 \times 29000)]^{1/4} = 0.2320"$$

USE 1/4" SKIN PLATE

For Tall Gates More Than One

Thickness May Be Required.

INTERCOSTAL DESIGN: LOAD CASE I2

Material: A36 Steel. Equations & Tables In Parentheses Are From The Specification In AISC (1989).

Load, shear, and moment diagrams for intercostals are shown on page C-5. Trial Section is shown on page C-6.

$$M = 5.839 \times 22/12 = 10.705 \text{ k-ft} = 128.46 \text{ k-in}$$

$$b_f/2t_f = 4.00/(2 \times 0.27) = 7.41$$

$$65/(F_y)^{1/2} = 65/6 = 10.83 > 7.41 \text{ Compact Section (Table B5.1)}$$

$$L_b = 5.515' = 66.18", L_b/r_T = 66.18/1.03 = 64.25$$

$$L_c = 76b/(F_y)^{1/2} = 76 \times 4/6 = 50.67 < 66.18 \text{ (F1-2)}$$

$$F_b = [2/3 - F_y(L_b/r_T)^2/(1530 \times 10^3)] F_y \text{ (F1-6)}$$

$$F_b = [2/3 - 36(64.25)^2/(1530 \times 10^3)] 36 = 20.50 \text{ ksi}$$

$$1.11 F_b = 22.78 \text{ ksi}$$

$$f_b = M/S = 128.46/6.84 = 18.78 \text{ ksi} < 22.78 \text{ ksi o.k.}$$

USE WT 5x7.5 FOR INTERCOSTALS. MAX. SPACING 1'-10"

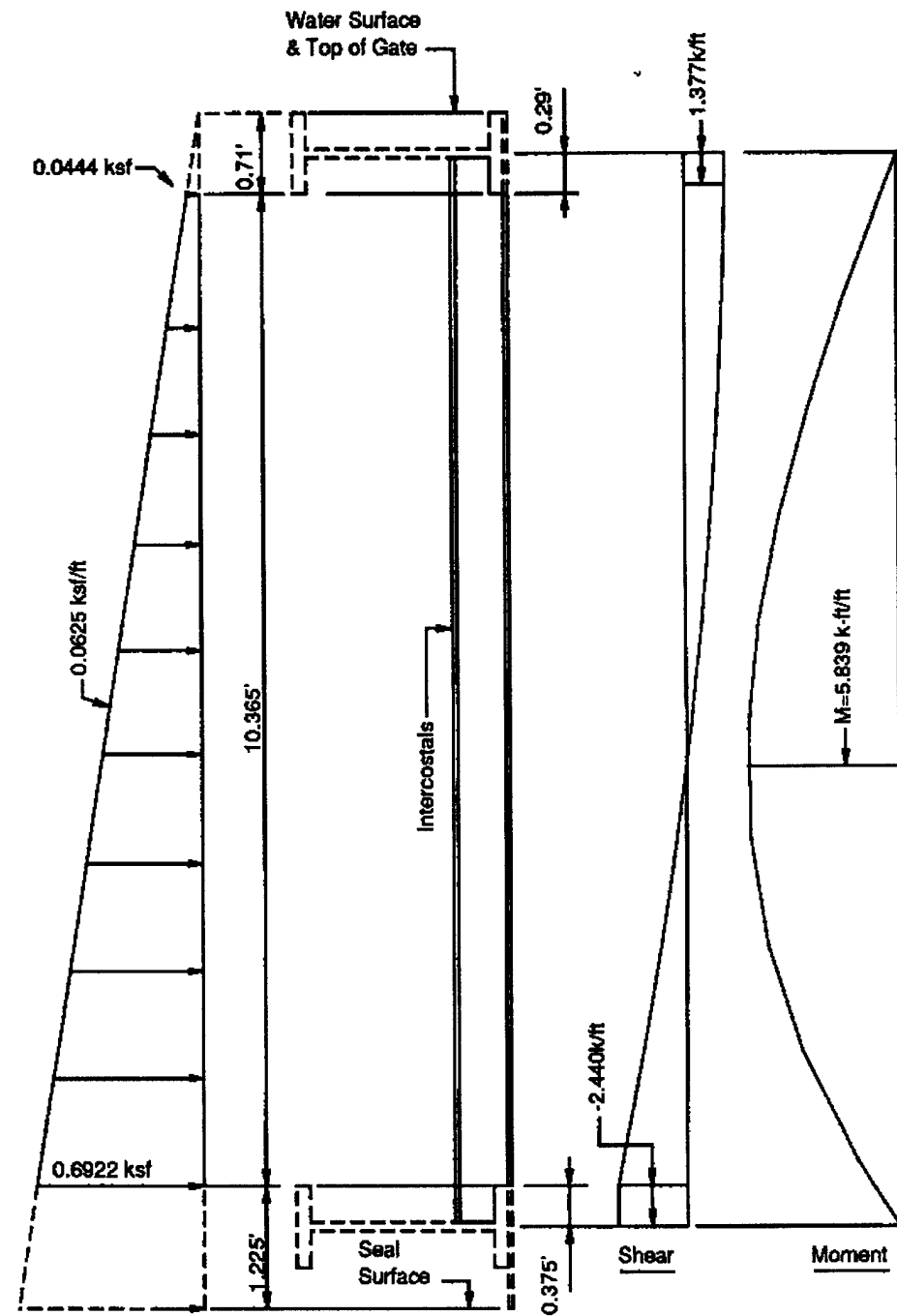

Hydrostatic Load

LOAD, SHEAR, & MOMENT DIAGRAMS
FOR
INTERCOSTALS

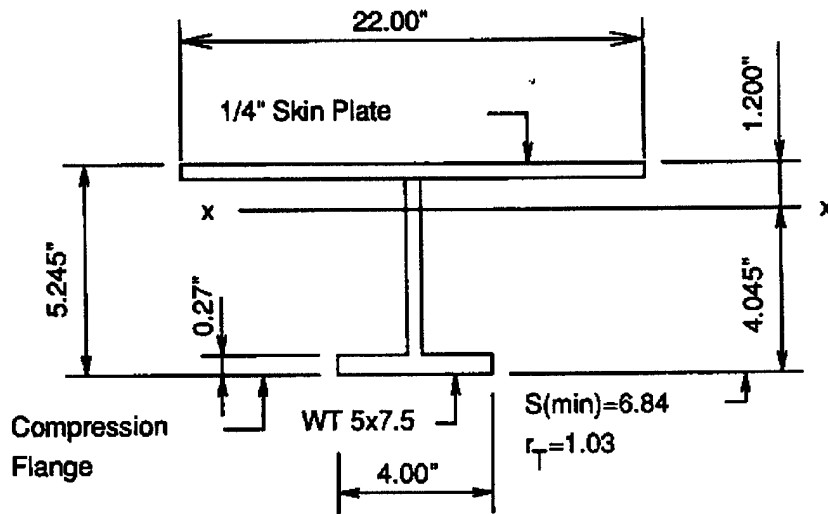

INTERCOSTAL SECTION

Girder Design (Mat'l. A36 Steel, Equation and Table Numbers
In Parentheses Are From Specification In AISC (1989).)

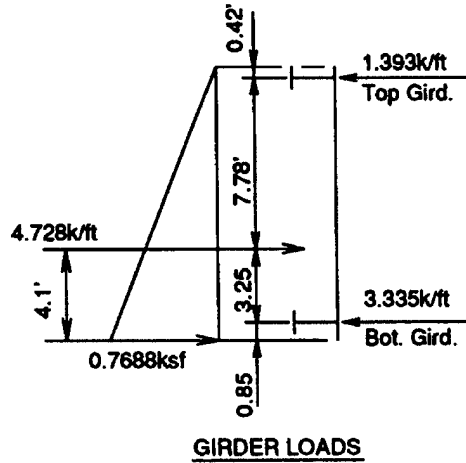

Bottom Girder

$M=3.335(31.59)^2(1/8)$
 $M=416.04\text{k-ft}=4992\text{k-in}$
 Trial Section W 24x84
 $I_x=2370, S_x=196$

$d/A_f=3.47, b_f=9", F_y=36\text{ksi}$

$b_f/2t_f=5.9, d/t_w=51.3$

(Table B5.1)

$65/(F_y)^{1/2}=10.83>5.9$

$640/(F_y)^{1/2}=106.67>51.3$

Flange & Web are compact

$L_b=66", L_c=76b_f/(F_y)^{1/2}=114">66" \text{ (F1-2)}$

$F_b=1.11 \times 0.66 \times F_y=26.67\text{ksi}, f_b=M/S_x=4992/196=25.47\text{ksi}<F_b$

USE W 24x84

See page C-18 for design with the effect of axial load & bending due to the diagonal

Top Girder

$M=1.393(31.59)^2(1/8)=173.76\text{k-ft}=2085\text{k-in}$

Trial Section W 24x55
 $I_x=1350, S_x=114, d/A_f=6.66$

$b_f/2t_f=6.9, d/t_w=59.7, L_b=66"$

Flange & Web are compact, see Table B5.1.

$L_c=20000/(6.66 \times 36)=83.42">66" \text{ (F1-2)}$

$F_b=1.11(2/3)(36)=26.67\text{ksi}$

$f_b=2085/114=18.29\text{ksi}<26.67\text{ksi}$

USE: W24x55

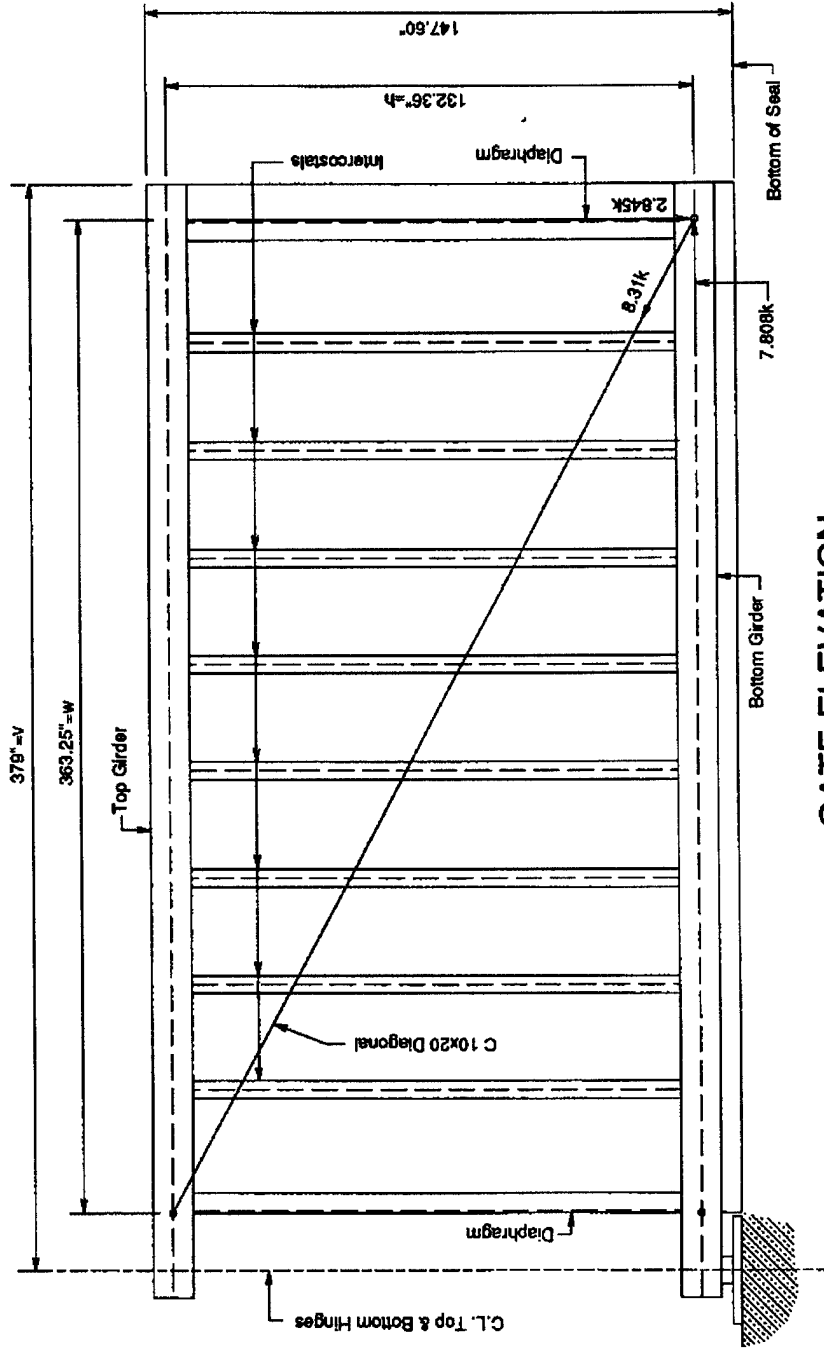

GATE ELEVATION
SHOWING DIAGONAL LOAD DUE TO D.L. TORSION

(See Page B-9 For Torsional Deflection & Diagonal Stress Calculations)

STRESS & DEFLECTION DUE TO DEAD LOAD TORSION

Methods For Determining The Shear Center And The Torsional Stiffness
Of The Gate Are Presented In EM 1110-2-2703

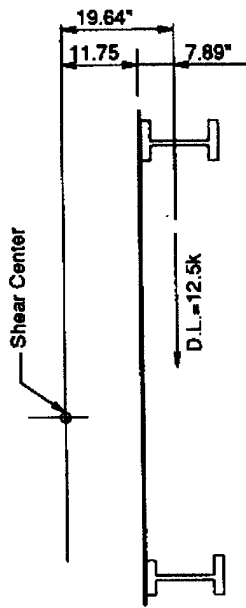

End View

$$T = \text{Torsion} = 12.5 \times 19.64 = 245.5 \text{ k-in}$$

$$Z = \text{Distance From Hinges To C.G. Of D.L.}$$

$$Z = 16.198' = 194.38''$$

$$TZ = 245.5 \times 194.38 = 47720$$

$$A = \text{Area C 10x20 Diagonal} = 5.88$$

$$A' = 1/8 \text{ Of Sum Of Girder \& Diaph. Areas}$$

$$A' = 10.11$$

$$L = [(132.36)^2 + (363.25)^2]^{1/2} = 386.61''$$

$$Q_0 = \text{Torsional Stiffness Of Gate} = 2442$$

$$t = \text{Dist. From C.L. Of Skin To C.G. Of Diagonal}$$

$$t = 22.97''$$

$$R_0 = 2wt/vL = 2 \times 363.25 \times 22.97 / (379 \times 386.61)$$

$$R_0 = 0.1139$$

$$R = A'R_0 / (A + A') = 10.11 \times 0.1139 / (5.88 + 10.11)$$

$$R = 0.072$$

$$Q = RR_0EA'tv/L = \text{Torsional Stiff. Diagonal}$$

$$Q = 181312, Q + Q_0 = 183754$$

$$\Delta = TZ / (Q + Q_0) = 47720 / 183754 = 0.26'' = \text{Torsional Defl. Of Gate.}$$

$$\text{Tensile Stress In Diagonal} = RE \Delta / L = 1.41 \text{ ksi}$$

$$\text{Tensile Load In Diagonal} = 1.41 \times 5.88 = 8.31 \text{ k}$$

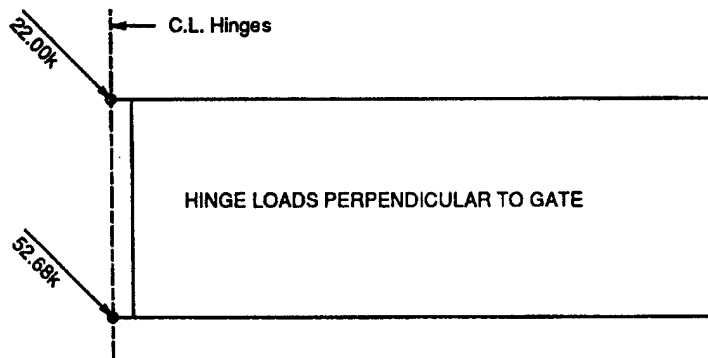
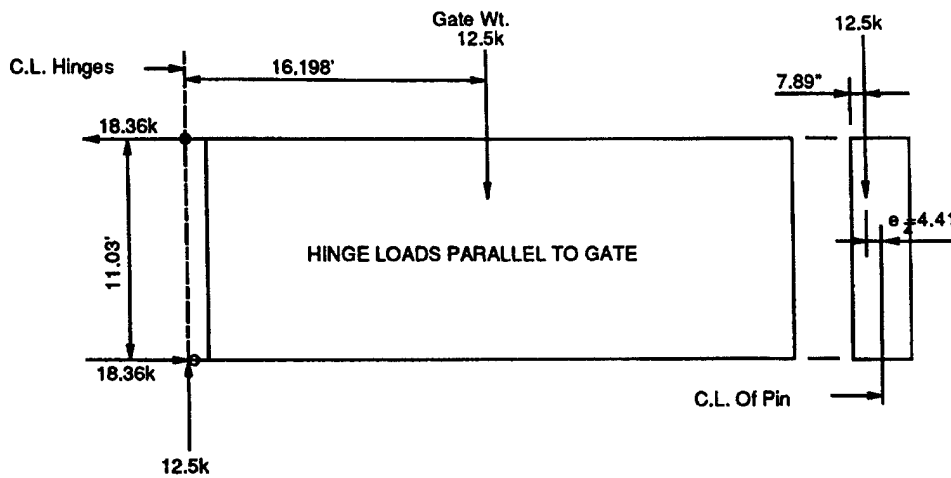

BOTTOM HINGE PIN

$P_y = 52.68k, P_x = 18.36k, P_z = 12.5k, e_z = 4.41"$

Assuming a 1.75" base plate, $Z = 7.85"$

$M_y = P_y Z + P_z e_z = 468.66k\text{-in}$

$M_x = P_x Z = 144.13 k\text{-in}$

$M_r = \sqrt{M_x^2 + M_y^2} = 490.32 k\text{-in}$

$d = \text{Pin Diameter} = 5", \text{Mat'l. A276, } F_y = 55 \text{ ksi}$

$A = 19.63, I = 30.68, S = 12.27, r = 1.25, kL/r = 2 \times 7.85 / 1.25 = 13$

$1.11F_b = 1.11 \times 0.75F_y = 45.83 \text{ ksi}, 1.11F_a = 35.43 \text{ ksi (Using AISC (1989))}$

$f_a = 12.5 / 19.63 = 0.637 \text{ ksi}, f_b = 490.32 / 12.27 = 39.96 \text{ ksi}$

$f_a / 1.11F_a + f_b / 1.11F_b = 0.890 < 1.000$

USE 5" DIAMETER PIN

BASE PLATE & BASE PLATE BOLTS:

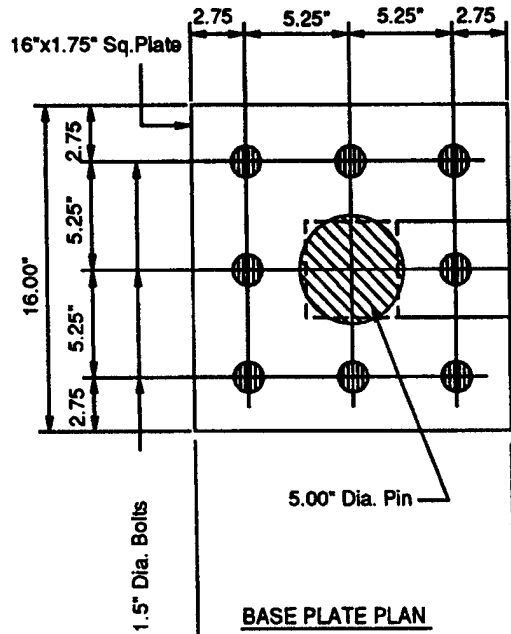

BASE PLATE PLAN

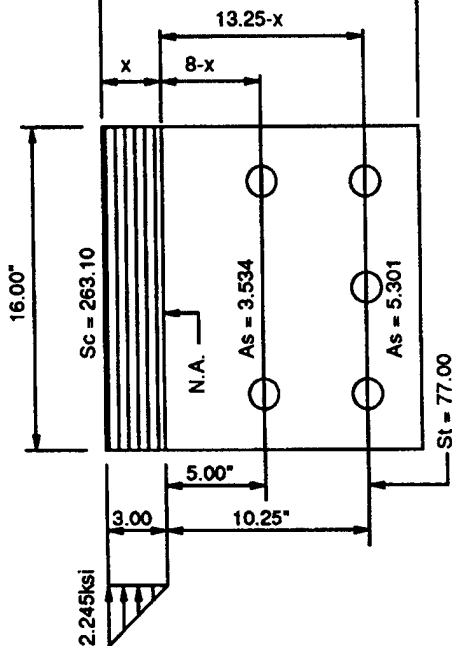

Brg. Press.

$$P = \sqrt{Px^2 + Py^2} = 55.79k$$

Moment at Bottom of Plate;

$$M = 55.79 \times 9.6 + 12.5 \times 4.41 = 590.71k\text{-in}$$

(neglect 12.5k vertical load)

Calculate Section Properties

At Bottom Of Plate.

$$8x^2 = 3.534(8-x) + 5.301(13.25-x)$$

$$8x^2 + 8.835x - 98.51025 = 0$$

$$x = 3.00"$$

Bolt Mat'l. F593, Alloy 316, $F_y = 30\text{ksi}$

$$I_{N.A.} = 16(3)^3/3 + 3.534(5)^2 + 5.301(10.25)^2 = 789.29\text{in}^4$$

$$S_c = 789.29/3 = 263.10$$

$$S_t = 789.29/10.25 = 77.00$$

$$f_c = 590.71/263.10 = 2.245\text{ksi}$$

$$f_t = 590.71/77.00 = 7.672\text{ksi}$$

$$F_t = 1.11 \times 0.6 \times 30 = 20\text{ksi}$$

$$F_v = 1.11 \times 0.4 \times 30 = 13.33\text{ksi}$$

$$f_v = 55.79/(8 \times 1.767) = 3.95\text{ksi}$$

USE 8-1.5" DIA. BOLTS F593

Moment in Plate at Edge of

Equiv. Square Pin =

$$0.5 \times 2.245 \times 3.00 \times 4.78 = 16.10k\text{-in}$$

$$S_{PL} = 1(1.75)^2/6 = 0.510$$

Mat'l. ASTM A276, $F_y = 55\text{ksi}$

$$1.11F_b = 1.11 \times 0.75 \times 55 = 45.83\text{ksi}$$

$$f_b = 16.10/0.510 = 31.57\text{ksi} < 45.83\text{ksi}$$

USE 16" SQ. x1.75" A276 PLATE

EMBEDDED PLATE & BOLTS: (Bolt Mat'l. F593, Alloy 316, Plate A36)

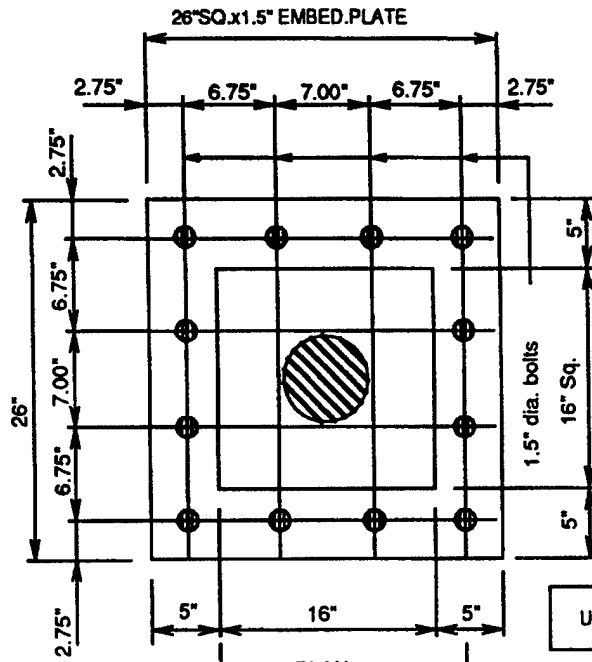

Properties of Transformed Section At Base Of Embed. Plate:

$n = E_s/E_c = 10$
 $13x^2 = 35.34(16.5-x) + 70.68(23.25-x)$
 $13x^2 + 106.02x - 2226.42 = 0$
 $x = 9.63"$
 $I_{N.A.} = 22519.21 \text{ in}^4$
 $S_c = 2338.44, S_t = 1653.39$
 $M = 55.79 \times 11.1 + 12.5 \times 4.41 = 674.39 \text{ k-in}$
 $f_c = M/S_c = 0.2884 \text{ ksi}$
 $f_t = M/S_t = 0.4079 \text{ ksi}$
 Bolt Tension = $nf_t = 4.079 \text{ ksi}$
 $F_t = 20 \text{ ksi}, F_v = 13.33 \text{ ksi}$

USE 12-1.5" DIA. F593 BOLTS

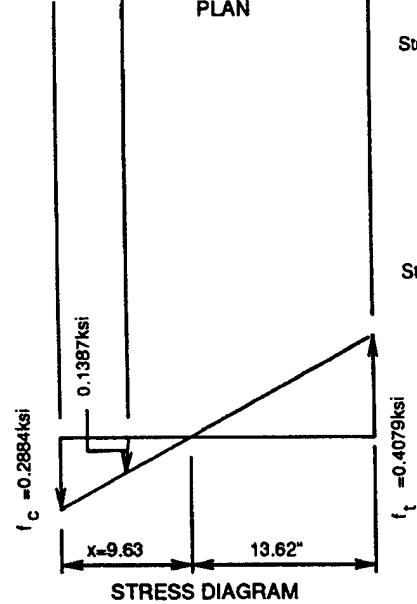

Stress At Edge Of Base Plate:

$S_{PL} = (1.5)^2/6 = 0.375$
 $M = 0.5(0.2884 + 0.1387)(5)(2.79) = 2.98 \text{ k-in}$
 $f_b = 2.98/0.375 = 7.95 \text{ ksi}$

Stress At Edge Of Equiv. Pin:

$M = 0.5(0.2884)(9.63)(8.57) = 11.90 \text{ k-in}$

Combined Section Modulus for Two Plates:

$S = 0.375 + 0.510 = 0.885$
 $f_b = M/S = 11.90/0.885 = 13.45 \text{ ksi}$

USE 26" SQ. x 1.5" A36 PLATE

See Page C-13 For Bending Stress In Embedded Bolts & Bolt Bearing Stress On Concrete.

BOLTS IN CONCRETE

Using Maximum Allowable Concrete Bearing Stress, Find The Minimum Required Bolt Embedment:

$f'_c = 3\text{ksi}$ (28 day concrete compressive strength)

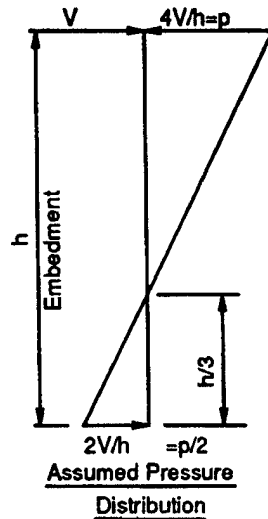

$$h = \text{Min. Embed.} = 4V/p$$

$$F_p = 0.35f'_c = 1.05\text{ksi} \text{ From Sect. J9 Of AISC (1989)}$$

$$d = \text{Bolt Dia.} = 1.5" \quad F_p(\text{for Case I2}) = 1.11 \times 1.05 = 1.167\text{ksi}$$

$$p = dF_p = 1.5 \times 1.167 = 1.75\text{k/in}$$

$$V = 55.79/12 = 4.65\text{k/Bolt}$$

$$h = 4 \times 4.65 / 1.75 = 10.63" = \text{Min. Embed. Req'd.}$$

Actual Embedment = 20" > 10.63" o.k.

Calculate Flexural Stress In Bolt:

$$M = \text{Max. Moment} = 4Vh/27 = 4 \times 4.65 \times 10.63 / 27 = 7.323\text{k-in}$$

$$S = \text{Bolt Sect. Mod.} = 0.3313$$

$$1.11(0.75F_y) = 1.11 \times 0.75 \times 30 = 25\text{ksi} = F_b$$

$$f_b = M/S = 7.323 / 0.3313 = 22.10\text{ksi} < 25\text{ksi} \text{ o.k.}$$

CALCULATE BOND STRESS DUE TO BOLT TENSION:

$$f_t = \text{Bolt Tensile Stress} = 4.079\text{ksi} \text{ (from page C-12)}$$

$$T = \text{Bolt Tension} = 4.079 \times 1.767 = 7.21 \text{ k/bolt}$$

$$L = \text{Embedment} = 20", \quad C = \text{Bolt Circumference} = 4.71"$$

$$U = \text{Allowable Bond Stress Concrete To Plain Bar}$$

$$U = 0.09\text{ksi} \text{ (3000psi Concrete)}$$

$$u = \text{Actual Bond Stress} = T/CL$$

$$u = 7.21 / (20 \times 4.71) = 0.0765\text{ksi} < U = 0.09\text{ksi}$$

BOND STRESS ALONE IS SUFFICIENT TO RESIST ANCHOR BOLT TENSION; HOWEVER, BOLTS SHALL HAVE 90 DEGREE HOOKS WITH 6" LEGS.

BUSHING DESIGN : (Mat'l. ASTM B22)

$$F_p = \text{Max. Allowable Avg. Brg. Stress} = 1.11 \times 3.00 = 3.33 \text{ ksi}$$

$$L_{\min} = P / (F_p \times D) = 55.79 / (3.33 \times 5) = 3.35" \quad \text{USE } L = 6"$$

See Page B-15 For Calculation Of Actual Max. Brg. Stress.

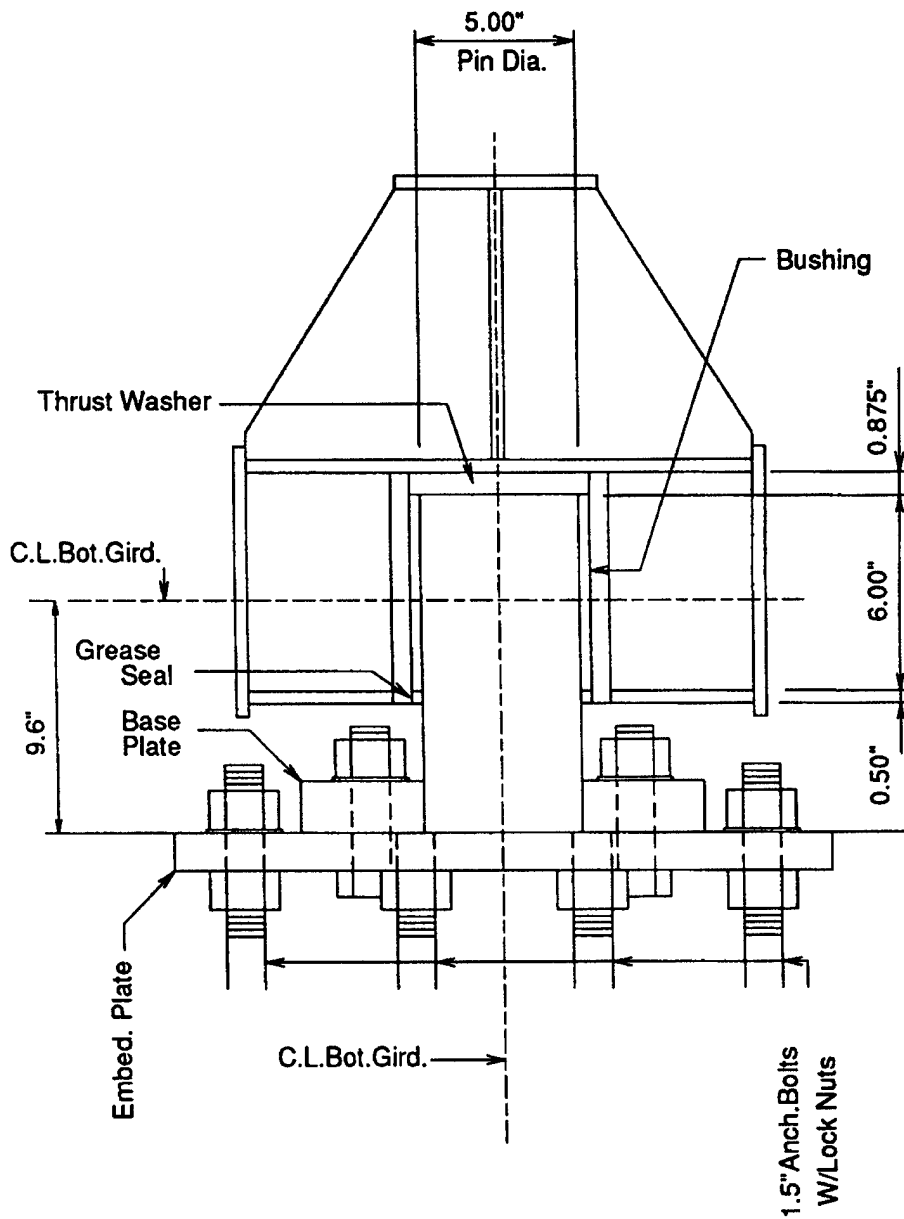

SECTION THRU BOTTOM HINGE

CALCULATION FOR ACTUAL MAXIMUM BEARING PRESSURE-BOTTOM PIN

L = Bushing Length = 6", Nominal Pin Diameter = 5"

R1 = Min. Radius Of Pin = 2.4985"

R2 = Max. Inside Radius Of Bushing = 2.5010"

E1 = Modulus Of Elasticity Of Pin = 29000ksi

E2 = Modulus Of Elasticity Of Bushing = 15000ksi

P1 = 55.79/6 = 9.30k/in

$$f_p \text{ max.} = 0.591 \sqrt{\frac{P1 E1 E2 (R2-R1)}{(E1+E2)(R1R2)}}$$

$$f_p \text{ max.} = 0.591 \sqrt{\frac{9.3 \times 435 \times 10^6 \times 0.0025}{44 \times 10^3 \times 6.24875}} = 3.584 \text{ ksi}$$

A Maximum Bearing Stress Equal To Or Less Than The Yield
Strength Of The Material Is Allowable.

TOP HINGE:

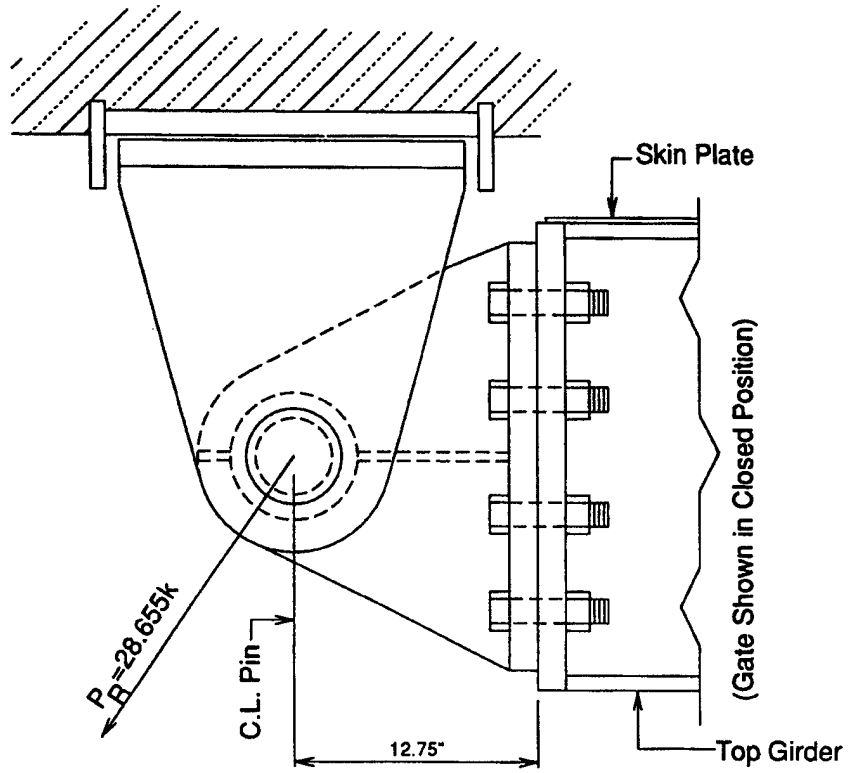

PLAN

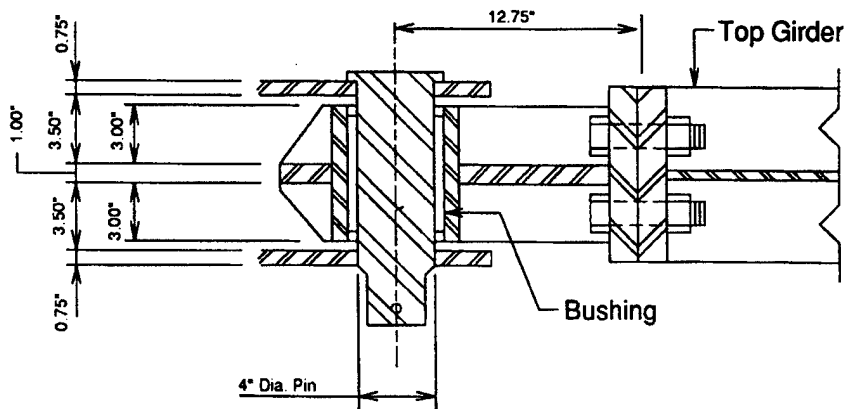

SECTION THRU HINGE

TOP PIN (Mat'l. ASTM A276, $F_y = 55\text{ksi}$)

$$P_R = 28.655\text{k}, V = 28.655/2 = 14.33\text{k (Dbl. Shear)}$$

$$M = 28.655 \times 8.75/4 = 62.68\text{k-in}$$

$$A = 3.1416(4)^2/4 = 12.57, S = 3.1416(4)^3/32 = 6.28$$

$$F_b = 1.11(0.75F_y) = 45.83\text{ksi}$$

$$F_v = 1.11(0.4F_y) = 24.44\text{ksi}$$

$$f_v = 14.33/12.57 = 1.14\text{ksi} < 24.44\text{ksi} \text{ o.k.}$$

$$f_b = 62.68/6.28 = 9.98\text{ksi} < 45.83\text{ksi} \text{ o.k.}$$

TOP BUSHING (Mat'l. ASTM B22)

$$P_R = 28.655\text{k}, \text{Bushing Length} = 6.00"$$

$$\text{Inside Dia.} = 4.00"$$

$$F_p = \text{Avg. Allowable Brg. Stress} = 1.11 \times 3.00 = 3.33\text{ksi}$$

$$f_p = 28.655/(4 \times 6) = 1.194\text{ksi} < 3.33\text{ksi} \text{ o.k.}$$

CHECK MAX. BEARING STRESS:

$$R_1 = 1.997", R_2 = 2.001"$$

$$E_1 = 29000\text{ksi}, E_2 = 15000\text{ksi}$$

$$P_1 = 28.655/6 = 4.78\text{k/in}$$

$$(\text{Max}) \quad f_p = 0.591 \sqrt{\frac{4.78 \times 29 \times 15 \times 10^6 (2.001 - 1.997)}{(29 + 15)(10^3)(2.001 \times 1.997)}} = 4.065\text{ksi}$$

A Maximum Bearing Stress Equal To Or Less Than The Yield Strength Of The Material Is Allowable.

Check Bottom Girder Design With Axial Load & Bending Due To Diagonal Included.

P = Axial Load From Diagonal = 7.808 k (See page C-8)
e = Eccentricity = 10.674", Pe = 83.34 k-in
M(Hs) = Moment Due To Hydrostatic Load = 4992 k-in (See page C-7)
M = Pe + M(Hs) = 83.34 + 4992 = 5075.34 k-in

Properties of W24x84:

$$A = 24.7, S = 196, r_x = 9.79, \frac{b_f}{2t_f} = 5.9, \frac{d}{t_w} = 51.3$$

Member is Compact (Table B5.1) $L_x = 379"$, $L_b = 66"$

$$\frac{KL_x}{r_x} = 39, f_a = \frac{7.808}{24.7} = 0.316 \text{ ksi}, F_a(AISC) = 19.27 \text{ ksi}$$

$$F_a = 1.11F_a(AISC) = 21.41 \text{ ksi}, F_b = \frac{M}{S} = 25.89 \text{ ksi}$$

$$\frac{76b_f}{\sqrt{F_y}} = 114'' > L_b = 66'', F_b(AISC) = 24 \text{ ksi}, F_b = 1.11 \times 24 = 26.67 \text{ ksi}$$

$$\frac{f_a}{F_a} < 0.15, \frac{f_a}{F_a} + \frac{f_b}{F_b} = < 1.00 \text{ (H1-3)}$$

$$\frac{0.316}{21.41} + \frac{25.89}{26.67} = 0.986 < 1.00$$

W24x84 Satisfies Axial Load & Flexural Requirements.

Appendix D Miter Gate Design Example

The opening in this example is 36 ft wide by 11.125 ft high.

Load Cases:

In accordance with EM 1110-2-2502, consideration was given to the following cases applicable to inland floodwalls.

Case I1, Design Flood Loading. Gate is mitered; water on the unprotected side is at the design flood elevation; water is at or below sill on protected side. Design stresses shall not be greater than 5/6 of stresses allowed in AISC (1989).

Case I2, Maximum Flood Loading. Same as Case I1 except that water level is to top of gate on unprotected side. Design stresses shall not be greater than 1.11 times the stresses allowed in AISC (1989).

Case I3, Earthquake Loading. Water is at usual level (nonflood condition) on unprotected side; earthquake-induced forces are acting. (Note: This case is applicable to support structures only.)

Case I4, Short-Duration Loading. Gate is either open or mitered or in between and is subjected to construction and/or wind loads. Design stresses shall not be greater than 1.11 times the stresses allowed in AISC (1989).

In this example, cases I1 and I3 are not significant and skin plate, intercostals, and girders are designed for Case I2. Case I4 is applicable to the design of diagonals and latching devices.

The skin plate is designed as a fixed end member spanning between intercostals. The hydrostatic pressure 6 ft above the flange of the bottom girder is used as a uniform load. In order for the design to meet the limitations of the flat plate theory, deflection is limited to 0.4 of plate thickness.

The intercostals are designed as simple beams spanning between girders.

Girders are designed as elements of a three-hinged arch. They are designed for thrusts and moments induced by diagonal tensions as well as for hydrostatic pressure.

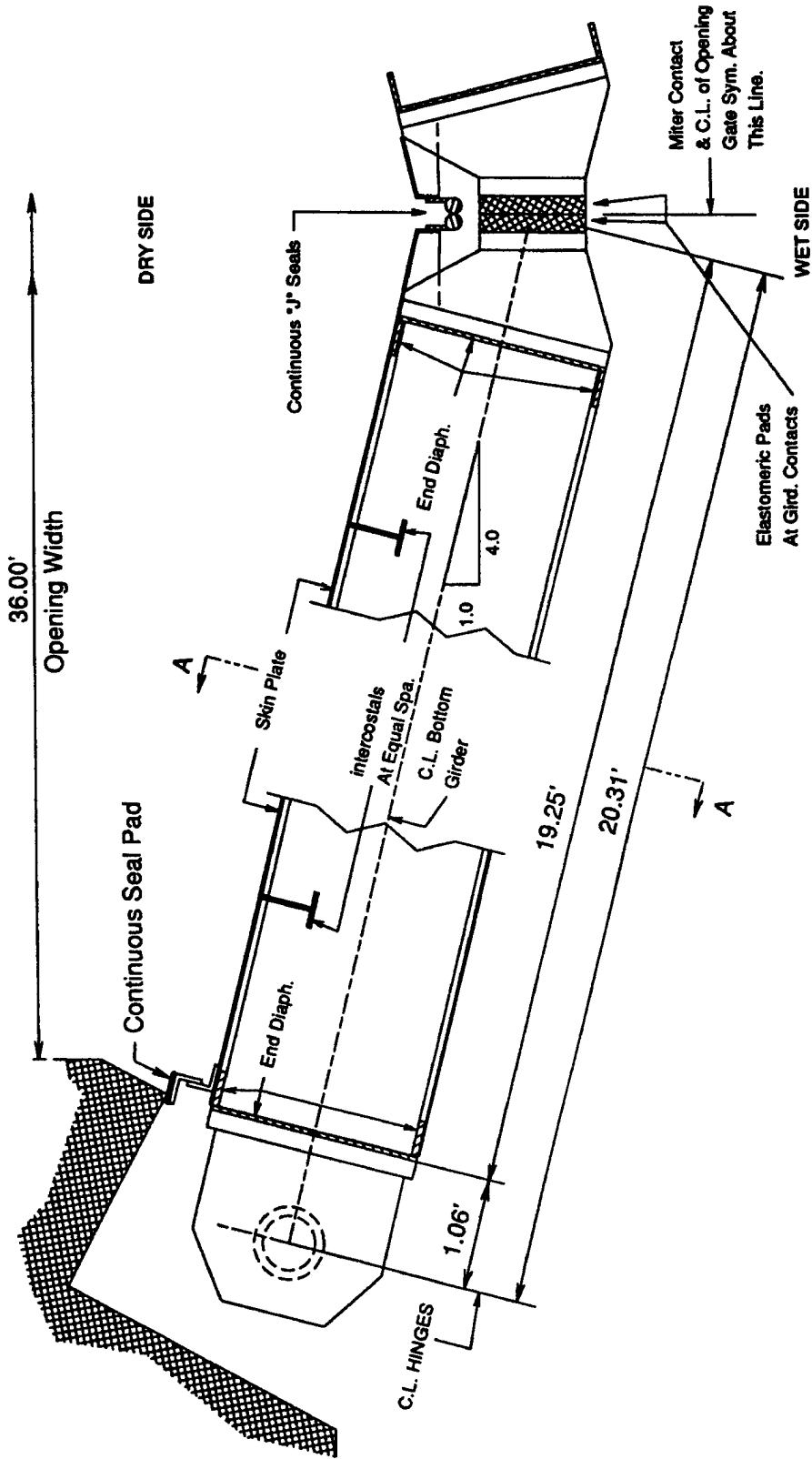

1/2 HORIZONTAL SECTION THRU GATE

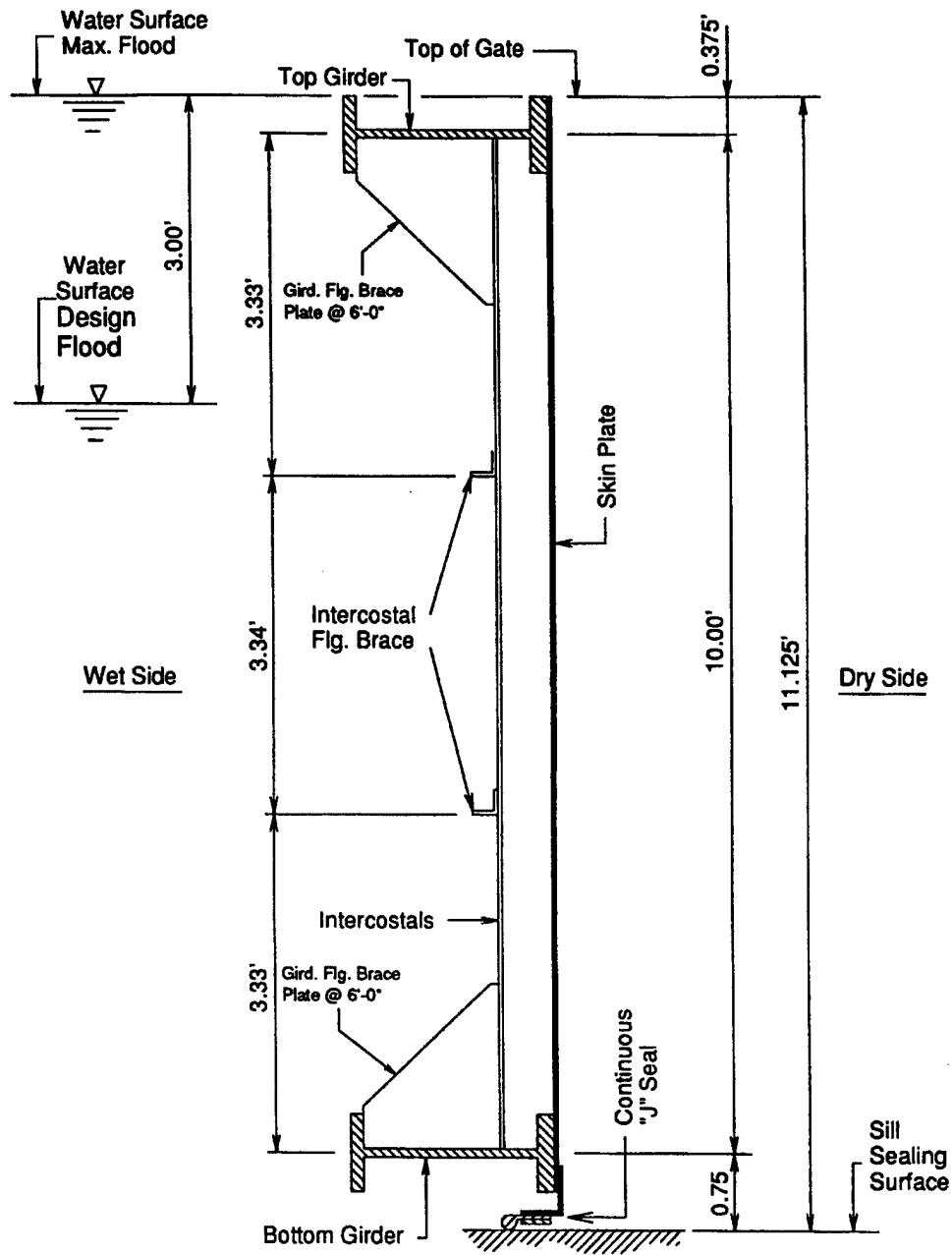

SECTION A-A

Skin Plate Design; Load Case I2:

Assuming 9" wide girder flanges, the hydrostatic pressure for skin plate design is:

$$p=0.0625(11.125-0.75-0.375-.5)=0.5983\text{ksf}$$

$$p=0.004124\text{ksi}, b=\text{intercostal spacing}=24"$$

$$M=pb^2/12=0.004124(24)^2/12=0.1980\text{k-in}$$

$$F_b=1.11(0.75F_y) = 1.11 \times 0.75 \times 36 = 30\text{ksi}$$

$$t_{\text{min-stress}}=(pb^2/2F_b)^{1/2}$$

$$t_{\text{min-stress}}=[0.004124(24)^2/(2 \times 30)]^{1/2}=0.1990"$$

$$\text{Defl.}=pb^4/384EI; E=29000; I=t^3/12; \text{Defl.}=0.4t$$

$$0.4t=12pb^4/384Et^3, t^4=pb^4/12.8E$$

$$t_{\text{min-defl.}}=[0.004124(24)^4/(12.8 \times 29000)]^{1/4}$$

$$t_{\text{min-defl.}}=\underline{0.2462"}$$

USE: 1/4" Skin Plate.

Intercostal Design; Load Case I2:

Eq. & Table No's. In Parentheses Are From AISC (1989).

Load, shear, and moment diagrams for intercostals are shown on page D-5.

$$M=4.27 \times 2' = 8.54\text{k-ft} = 102.48\text{k-in}$$

The trial section for intercostals is shown on page D-6.

$$S=5.47\text{in}^3, L_b=40"(\text{dist. between flg. braces})$$

$$b_f/2t_f=3.96/(2 \times 0.21)=9.43$$

$$65/(F_y)^{1/2}=65/6=10.83 > 9.43, \text{compact (Table B5.1)}$$

$$L_c=76b_f/(F_y)^{1/2}=76(3.96)/6=50.16" > 40" (F1-2)$$

$$F_b=1.11(2/3)F_y=1.11(2/3)(36) = 26.67\text{ksi}$$

$$f_b=M/S=102.48/5.47=18.73\text{ksi} < F_b=26.67\text{ksi}$$

USE: WT 5x6 for Intercostals.

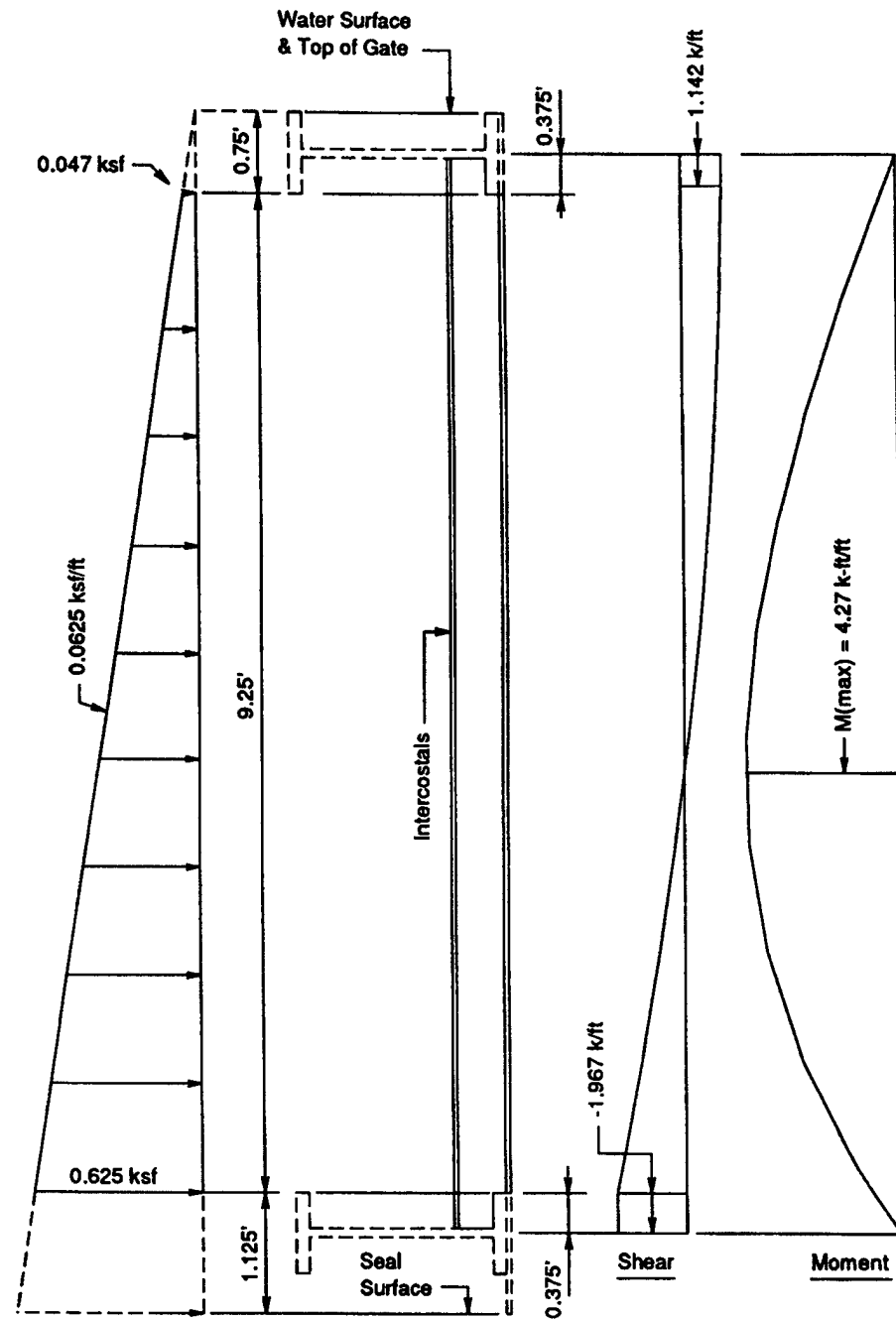

Hydrostatic Load

LOAD, SHEAR, & MOMENT DIAGRAMS
FOR
INTERCOSTALS

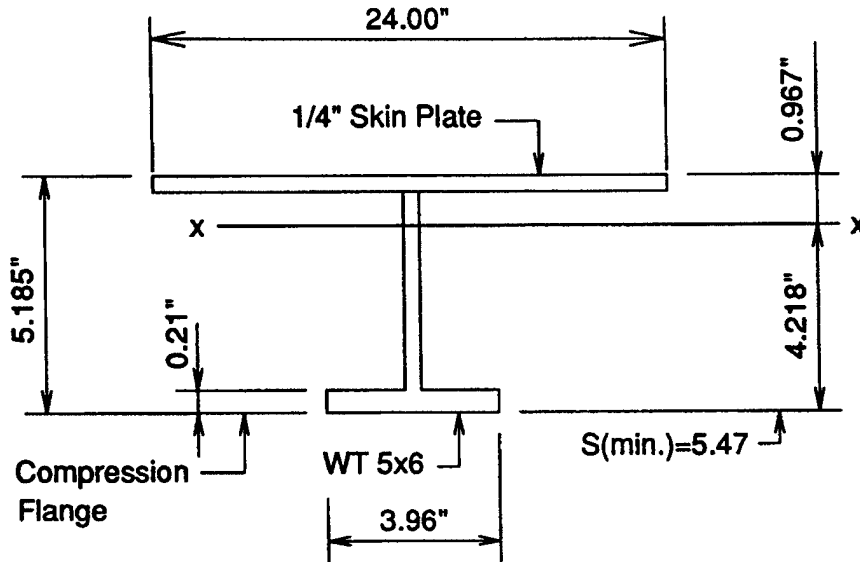

INTERCOSTAL SECTION

CALCULATION FOR DIAGONAL LOADS

Methods For Determining The Shear Center And The Torsional Stiffness Of The Gate Are Presented In EM 1110-2-2703.

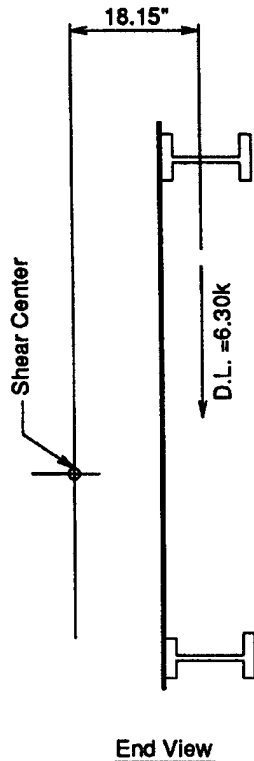

$$T = \text{Torsion} = 6.30 \times 18.15 = 114.35 \text{ k-in}$$

$$Z = \text{Distance From Hinges To C.G. Of D.L.}$$

$$Z = 123"$$

$$TZ = 14065 \text{ k-in}^2$$

$$A = \text{Area Of Diagonal} = 0.79$$

$$A' = 1/8 \text{ Of Sum Of Girder \& Diaph. Areas}$$

$$A' = 8.05$$

$$L = \text{Length Of Diagonal} = 253.24"$$

$$Q_0 = \text{Torsional Stiffness Of Gate Leaf} = 1222$$

$$t = \text{Dist. From C.L. Of Skin To C.G. Of Diagonal}$$

$$t = 24.2"$$

$$R_0 = 2wt/VL = 2 \times 223 \times 24.2 / (243.72 \times 253.24) = 0.175$$

$$R = A' R_0 / (A + A')$$

$$R = 8.05 \times 0.175 / (0.79 + 8.05)$$

$$R = 0.159$$

$$Q = R R_0 E A h^3 / L = \text{Torsional Stiff. Diagonal}$$

$$Q = 0.159 \times 0.175 \times 29000 \times 0.79 \times 120 \times 243.72 / 253.24 = 73620$$

$QD_p + QD_n = TZ$ Where D_p is Prestress Deflection For Positive Diagonal and D_n is Prestress Deflection For Negative Diagonal.

Positive Diagonal Extends From Top Girder At Hinge End To Bottom Girder At Miter End.

$$\text{Let } D_n = 0.40", QD_n = 73620 \times 0.40 = 29448$$

$$73620 D_p = 14065 + 29448 = 43513, D_p = 43513 / 73620 = 0.59"$$

$$S_p = R D_p E / L = 0.159 \times 0.59 \times 29000 / 253.24 = 10.74 \text{ ksi}$$

$$S_n = R D_n E / L = 0.159 \times 0.40 \times 29000 / 253.24 = 7.28 \text{ ksi}$$

$$\text{Tension In Positive Diagonal} = 0.79 \times 10.74 = 8.48 \text{ k}$$

$$\text{Tension In Negative Diagonal} = 0.79 \times 7.28 = 5.75 \text{ k}$$

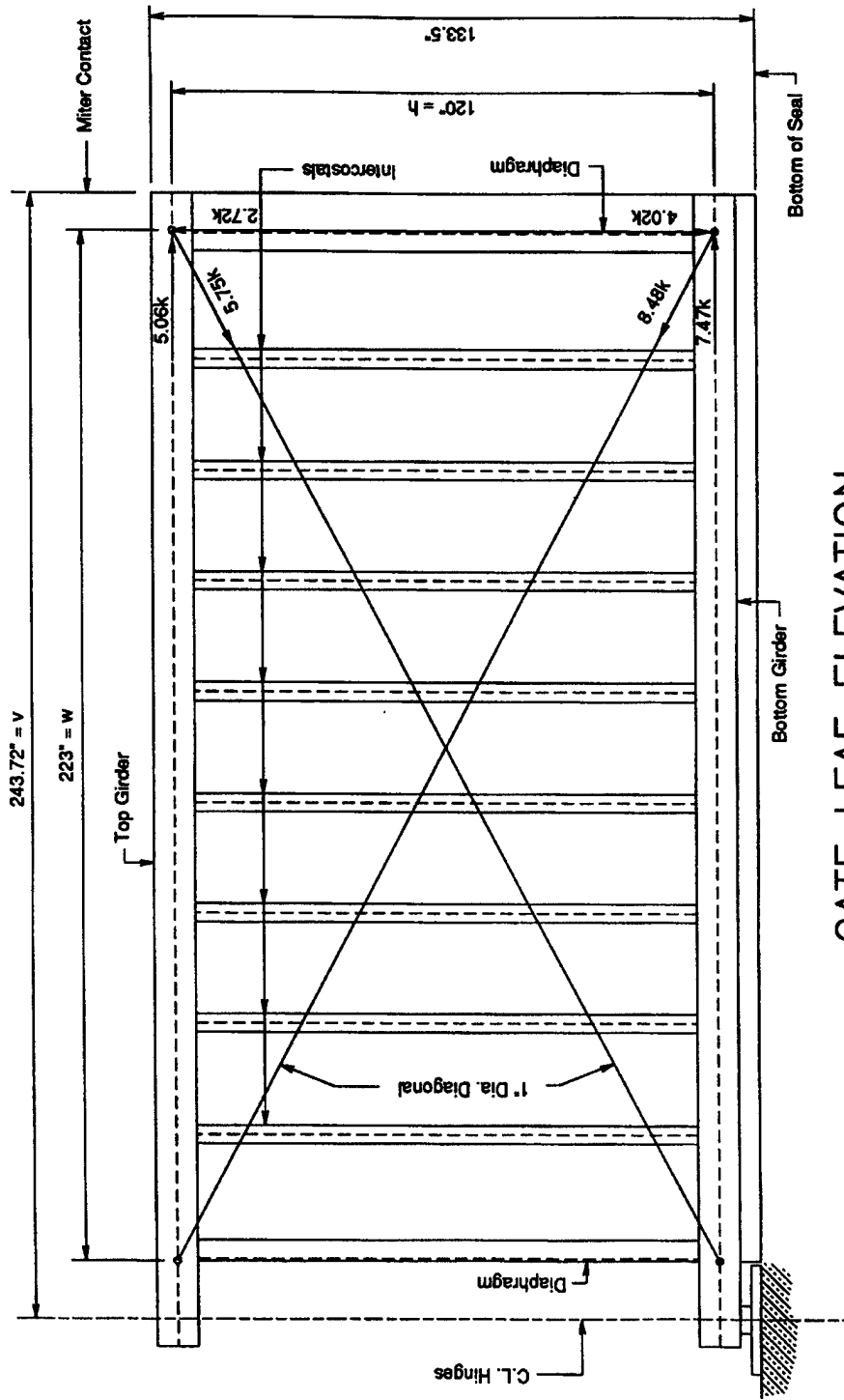

GATE LEAF ELEVATION
SHOWING DIAGONAL LOADS

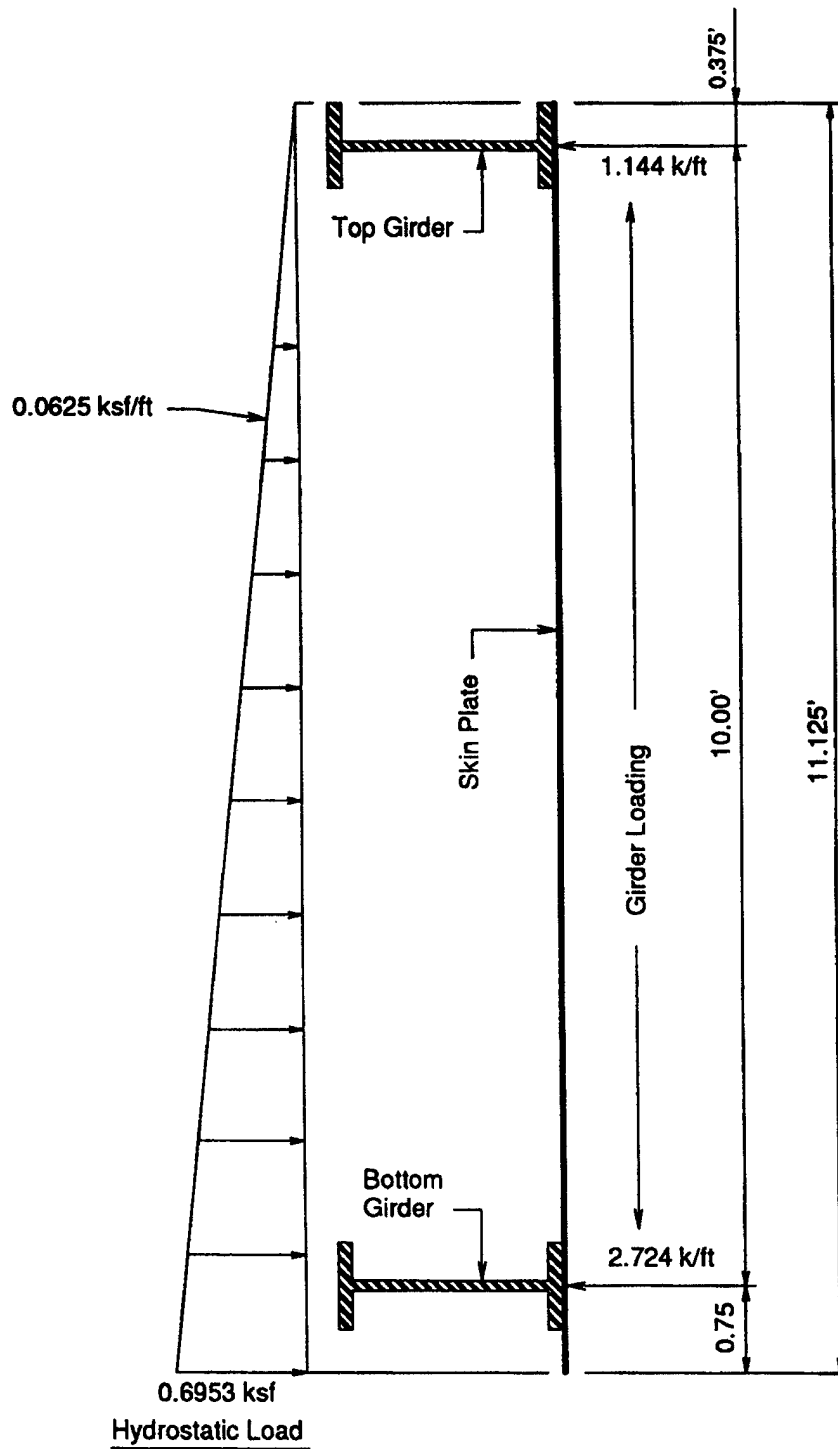

GIRDER LOADING

HYDROSTATIC LOADING & REACTIONS FOR BOTTOM GIRDER:

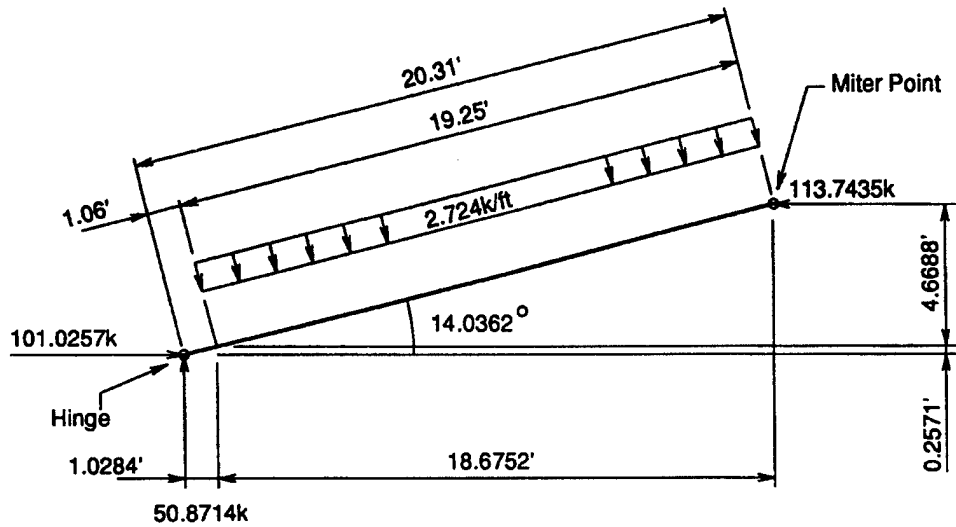

Free Body Of Bottom Girder

Resolve Reactions At Hinge Into Components Normal
And Parallel To Girder Centerline:

V = Normal Component, T = Parallel Component
 $V = 50.8714 \times \cos(14.0362) - 101.0257 \times \sin(14.0362) = 24.850k$
 $T = 50.8714 \times \sin(14.0362) + 101.0257 \times \cos(14.0362) = 110.347k$

Resolve Reaction At Miter Point Into Components Normal
And Parallel To Girder Centerline:

$V = 113.7435 \times \sin(14.0362) = 27.587k$
 $T = 113.7435 \times \cos(14.0362) = 110.347k$

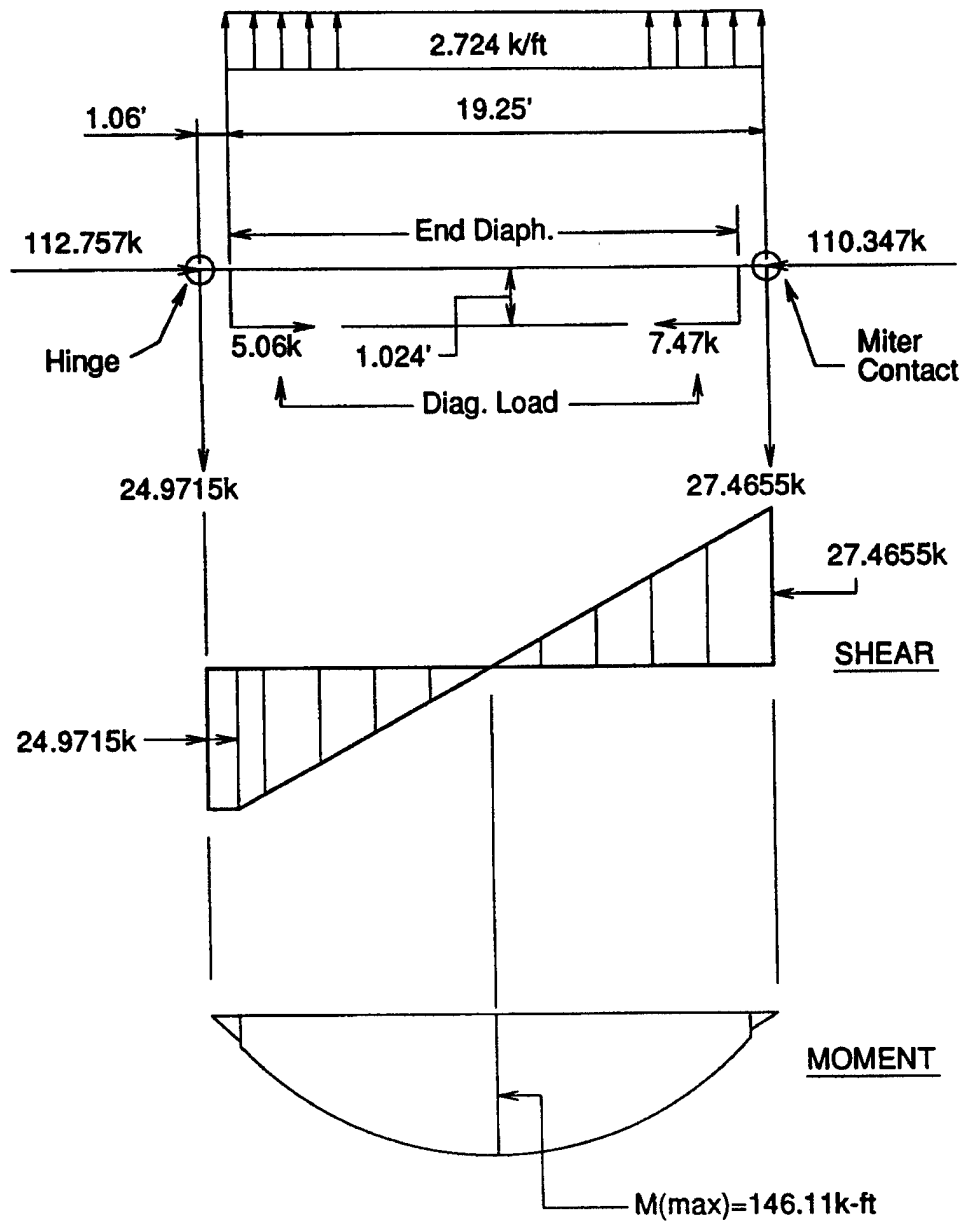

LOAD, REACTIONS, SHEAR, & MOMENT
FOR
BOTTOM GIRDER

BOTTOM GIRDER DESIGN

Material: ASTM A36

Equation & Table Numbers In Parentheses Are From Spec. In AISC (1989).

Trial Section, W 24x55.

$$A=16.2, S_x=114, r_x=9.11, r_y=1.34, r_T=1.68, d/A_f=6.66$$

$$b_f=7", t_f=0.505", b_f/2t_f=6.9, d=23.57", h=22.56"$$

$$t_w=0.395", d/A_w=59.7, h/t=57.11$$

$$L_x=20.31'=244", L_y=24", L_b=72"$$

$$P=112.757+5.06=117.817k, M=146.11k-ft=1753.32k-in$$

Allowable Stresses:

$$65/(F_y)^{1/2}=65/6=10.83>6.9 \text{ (Table B5.1)}$$

$$L_c=20000/(6.66 \times 36)=83.42>L_b=72"$$

$$640/(F_y)^{1/2}=640/6=106.67>59.7 \text{ (Table B5.1)}$$

W 24x55 is compact for flexure, $F_b=1.11(2/3)F_y=26.67\text{ksi}$

$$257/(F_y)^{1/2}=257/6=42.83<59.7 \text{ (Table B5.1)}$$

Web is a slender element under uniform compression.

$$h_e=[253t_w/(t)^{1/2}][1-44.3t_w/h(t)^{1/2}] \text{ (A-B5-8)}$$

$$f_a=P/A=117.817/16.2=7.27\text{ksi}, f_b=M/S=1753.32/114=15.38\text{ksi}$$

$$f=7.27+15.38=22.65\text{ksi}, (f)^{1/2}=4.76$$

$$h_e=[253 \times 0.395/4.76][1-44.3/(57.11 \times 4.76)]=17.57"$$

$$A_e=16.2-(22.56-17.57)(0.395)=14.23$$

$$Q=A_e/A=14.23/16.2=0.8784$$

$$L_x/r_x=244/9.11=27, L_y/r_y=24/1.34=18$$

$$F_a=1.11 \times 20.15=22.39\text{ksi} \text{ (E2-1)}$$

$$F_e=1.11 \times 204.84=227.6\text{ksi} \text{ (From Sect. H1 of AISC (1989))}$$

$$F_a=QF_e=0.8784 \times 22.39=19.67\text{ksi} \text{ (For Case I2)}$$

Combined Stresses:

$$f_a/F_a + Cmf_b/[1-f_a/F_e]F_b < 1.00' \text{ (H1-1)}$$

$$7.27/22.39 + 1 \times 15.38/[(1-7.27/227.6)(26.67)]=0.92 < 1.00$$

USE W24x55

Also Use W 24x55 For Top Girder To Maintain 24" Depth
So That Diagonals Lie In A Vertical Plane.

BOTTOM HINGE-PEDESTAL DESIGN

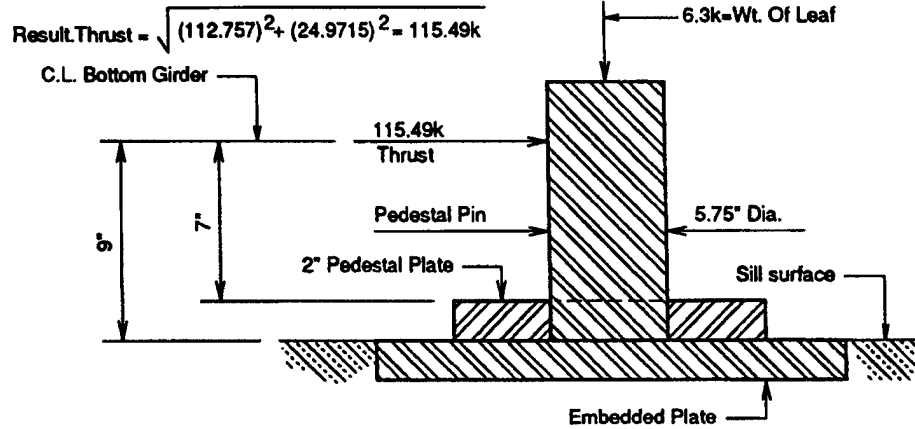

Pin Mat'l.: ASTM A276

Section Thru Pedestal

Pedestal Pin

$$F_y = 55 \text{ ksi. } F_b = 1.11 (0.75F_y) = 45.83 \text{ ksi}$$

$$d = 5.75", A = 25.97 \text{ in}^2, I = 53.66 \text{ in}^4$$

$$S = 18.66 \text{ in}^3, r = 1.44$$

$$L = 7", K = 2, KL/r = 2 \times 7 / 1.44 = 9.72$$

$$C_c = 102 \text{ (Ref. 3.d.(1).)}$$

$$FS = 5/3 + 3(KL/r)/(8 \times C_c) - [KL/rC_c]^3/8 = 1.70$$

$$F_a = [1 - 0.5(KL/C_c)^2][F_y]/FS = 32.17 \text{ ksi (AISC 1989)}$$

$$F_a = 1.11 \times 32.17 = 35.74 \text{ ksi}$$

$$M = 115.49 \times 7 = 808.43 \text{ k-in}$$

$$f_a = 6.3/25.97 = 0.243 \text{ ksi}$$

$$f_b = 808.43/18.66 = 43.32 \text{ ksi}$$

$$f_a/F_a + f_b/F_b = 0.243/35.74 + 43.32/45.83 = 0.952 < 1.000$$

USE 5.75" Diameter Pin

PEDESTAL BASE PLATE

Material: Bolts F593, Alloy 316. Plate ASTM A276.

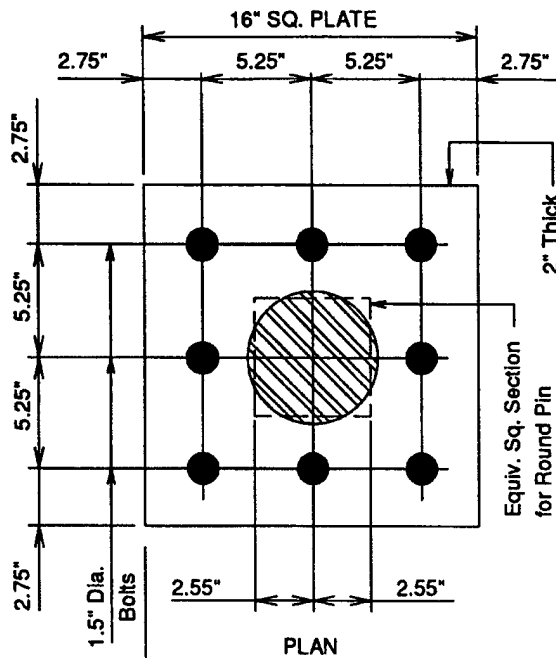

BOLTS:

$V = 115.49k$

$M = 115.49 \times 9 = 1039.41k\text{-in}$

$f_c = M/Sc$

$f_c = 1039.41/263.10 = 3.95\text{ksi}$

$f_t = M/St$

$f_t = 1039.41/77 = 13.50\text{ksi}$

Bolt Area At Thread = 1.41

$f_t \text{ (at thread)} = 1.767 \times 13.5 / 1.41 =$

$= 16.92\text{ksi}$

$F_y = 30\text{ksi}$

$F_t = 1.11 \times 0.6 \times 30 = 20\text{ksi} > 16.92\text{ksi}$

$f_v = 115.49 / (8 \times 1.41) = 10.24\text{ksi}$

$F_v = 1.11 \times 0.4 \times 30 = 13.33\text{ksi} > 10.24\text{ksi}$

USE 8-1.50" DIA. BOLTS

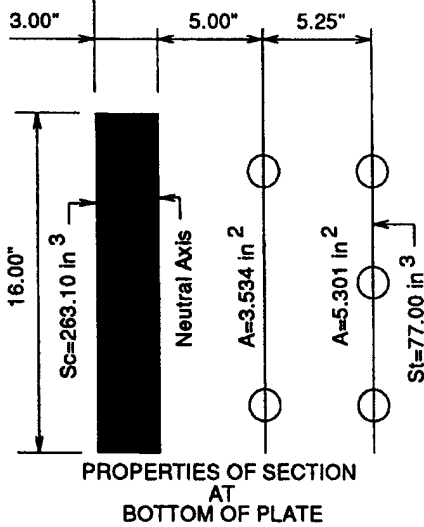

PROPERTIES OF SECTION
AT
BOTTOM OF PLATE

PLATE:

Moment in plate at edge of equiv. Sq. Pin.

$M = 0.5 \times 3.95 \times 3 \times 4.45 \times 16 = 421.86k\text{-in}$

$S = 16(2)^2/6 = 10.67$

$f_b = M/S = 421.86/10.67 = 39.54\text{ksi}$

$F_y = 55\text{ksi}$

$F_b = 1.11 \times 0.75 \times 55 = 45.83\text{ksi} > 39.54\text{ksi}$

USE 16" SQUARE X 2" PLATE

EMBEDDED PLATE & BOLTS: (Bolt Mat'l. F593, Alloy 316. Plate A36)

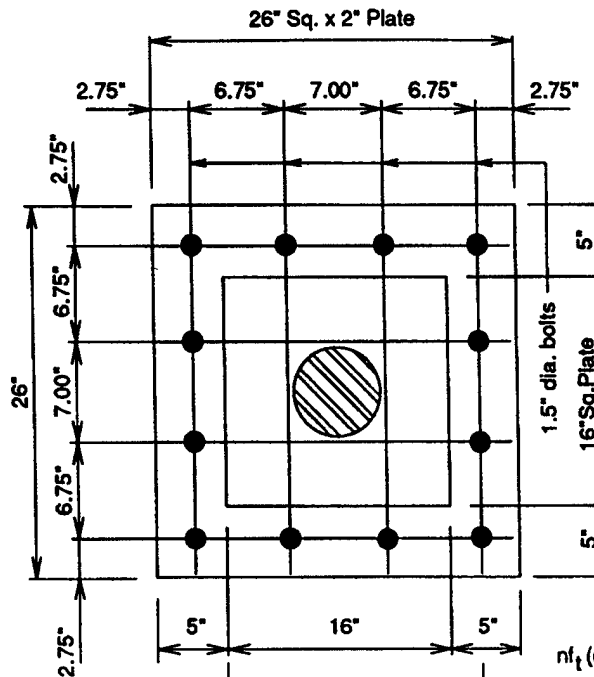

BOLTS:

Transformed Section, $n = 10$

$$I_{N.A.} = 22519.21$$

$$S_c = 2338.44, S_t = 1653.39$$

$$V = 115.49k$$

$$M = 115.49 \times 11 = 1270.39k\text{-in}$$

$$f_p = M/S_c = 0.543\text{ksi}$$

$$F_p = 1.11 \times 0.35 f_c$$

$$F_p = 1.11 \times 0.35 \times 3 = 1.167\text{ksi}$$

$$F_p > f_p$$

$$f_t = M/S_t = 0.7684\text{ksi}$$

$$F_y = 30\text{ksi}$$

$$F_t = 1.11 \times 0.6 \times 30 = 20\text{ksi}$$

$$A(\text{bolt}) = 1.767, A(\text{@ th'ds.}) = 1.41$$

$$n f_t = 10 \times 0.7684 = 7.684\text{ksi}$$

$$n f_t (\text{@ th'ds.}) = 1.767 \times 7.684 / 1.41 = 9.63\text{ksi}$$

$$F_t > 9.63\text{ksi}$$

$$F_v = 1.11 \times 0.4 \times F_y = 13.33\text{ksi}$$

$$f_v = 115.49 / (12 \times 1.767) = 5.45\text{ksi} < 13.33\text{ksi}$$

USE 12-1.5" DIA. BOLTS

PLATE @ EDGE OF PED. PLATE:

$$M = 0.5(0.543 + 0.261)(5)(2.79)(26) =$$

$$M = 145.80k\text{-in}, S = 26(2)^2/6 = 17.33$$

$$f_b = M/S = 8.41\text{ksi}$$

$$F_b = 1.11 \times 0.67 \times 36 = 26.67\text{ksi} > 8.41\text{ksi}$$

PLATE @ EDGE OF EQUIV. SQ. PIN:

$$M = 0.5(0.543)(9.63)(7.24)(26) =$$

$$M = 492.16k\text{-in}$$

$$S(\text{both plates}) = 10.67 + 17.33 = 28$$

$$f_b = M/S = 17.58\text{ksi} < 26.67\text{ksi}$$

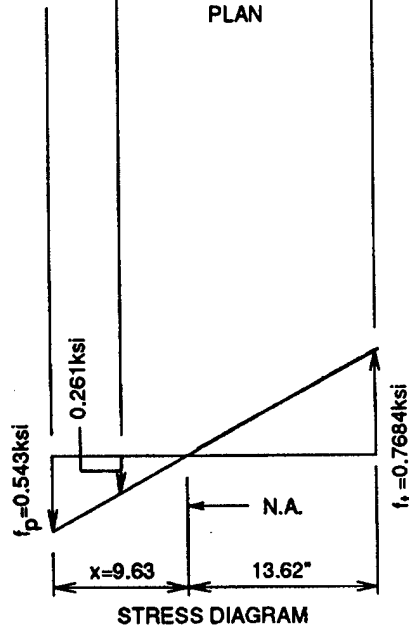

See Page D-16 For Bending Stress In Embedded Bolts & Bolt
Bearing Stress On Concrete.

BOLTS IN CONCRETE

Using Maximum Allowable Concrete Bearing Stress Find the
Minimum Required Bolt Embedment:

$f'_c = 3\text{ksi}$ (28 day concrete compressive strength)

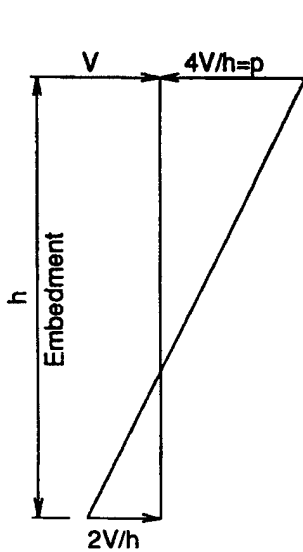

$h = \text{Min. Embed.} = 4V/p$

$F_p = 0.35f'_c = 1.05\text{ksi}$ From Sect. J9 Of AISC (1989).

$d = \text{Bolt Dia.} = 1.5" F_p \text{ (for Case I2)} = 1.11 \times 1.05 = 1.167\text{ksi}$

$p = dF_p = 1.5 \times 1.167 = 1.75\text{k/in}$

Total Horizontal Load On Embedment = 115.49k

Allowable Brg. Load On 2" Plate = $1.167 \times 26 \times 2 = 60.68\text{k}$

Shear Load On Embedded Bolts = $115.49 - 60.68 = 54.81\text{k}$

$V = 54.81/12 = 4.568\text{k/bolt}$

$h = 4 \times 4.568 / 1.75 = 10.44"$ (min req'd.)

Actual Embed. = 17" > 10.44" o.k.

Calculate Flexural Stress In Bolt:

$M = 4Vh/27 = 4 \times 4.568 \times 10.44 / 27 = 7.065\text{k-in}$

$S = \text{Bolt Sect. Mod.} = 0.3313$

$1.11(0.75F_y) = 1.11 \times 0.75 \times 30 = 25\text{ksi} = F_b$

$f_b = M/S = 7.065 / 0.3313 = 21.33\text{ksi} < 25\text{ksi}$ o.k.

BUSHING DESIGN : (Mat'l. ASTM B22)

$$F_p = \text{Max. Allowable Avg. Brg. Stress} = 1.11 \times 3.00 = 3.33 \text{ ksi}$$

$$\text{USE: } L=7" , D=5.75" , P=115.49 \text{ k} , f_p = P/DL$$

$$f_p = 115.49 / (7 \times 5.75) = 2.869 \text{ ksi} < 3.33 \text{ ksi}$$

See Page D-18 For Calculation Of Max. Bearing Stress.

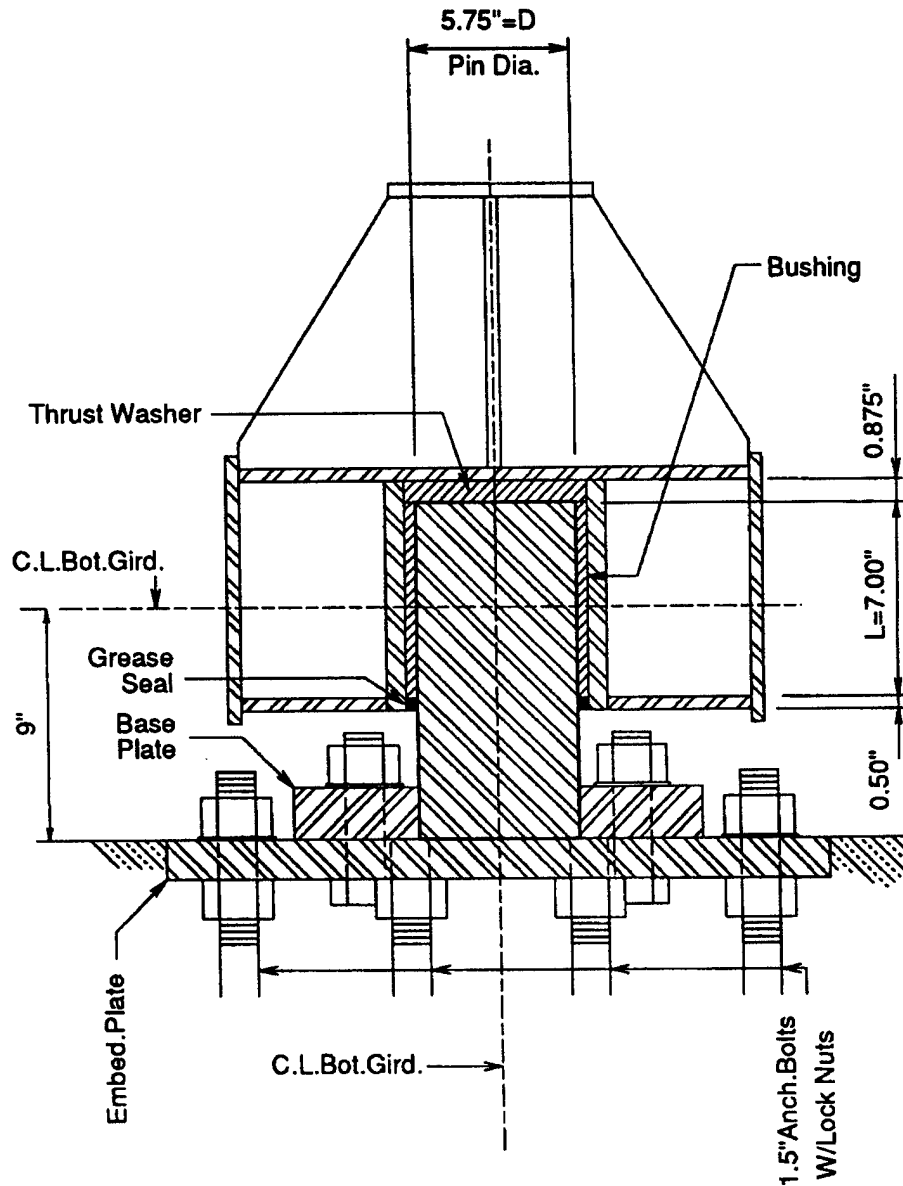

SECTION THRU BOTTOM HINGE

CALCULATION FOR ACTUAL MAXIMUM BEARING PRESSURE-BOTTOM PIN

L = Bushing Length = 7", Nominal Pin Diameter = 5.75"

R1 = Min. Radius Of Pin = 2.8670"

R2 = Max. Inside Radius Of Bushing = 2.8715"

E1 = Modulus Of Elasticity Of Pin = 29000ksi

E2 = Modulus Of Elasticity Of Bushing = 15000ksi

P1 = 115.49/7 = 16.50k/in

$$f_p \text{ max.} = 0.591 \sqrt{\frac{P1 E1 E2 (R2-R1)}{(E1+E2)(R1R2)}}$$

$$f_p \text{ max.} = 0.591 \sqrt{\frac{16.5 \times 435 \times 10^6 \times 0.0045}{44 \times 10^3 \times 8.25843}} = 5.572 \text{ksi}$$

A Maximum Bearing Stress Equal To Or Less Than The Yield Strength Of The Material Is Allowable.

TOP HINGE:

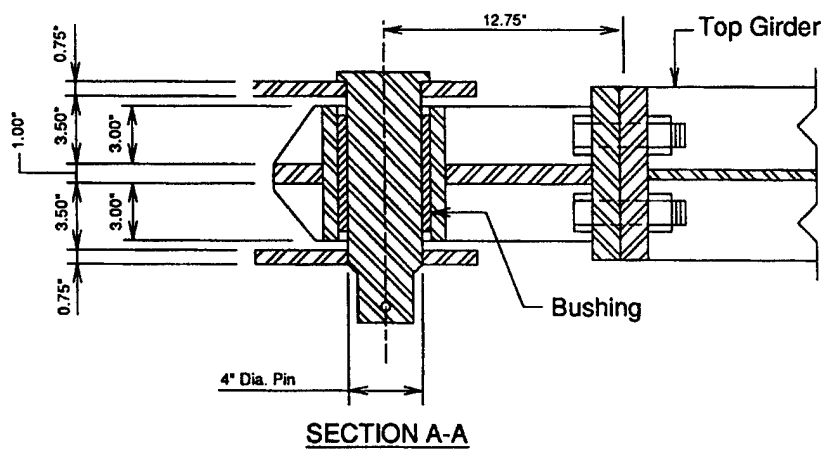
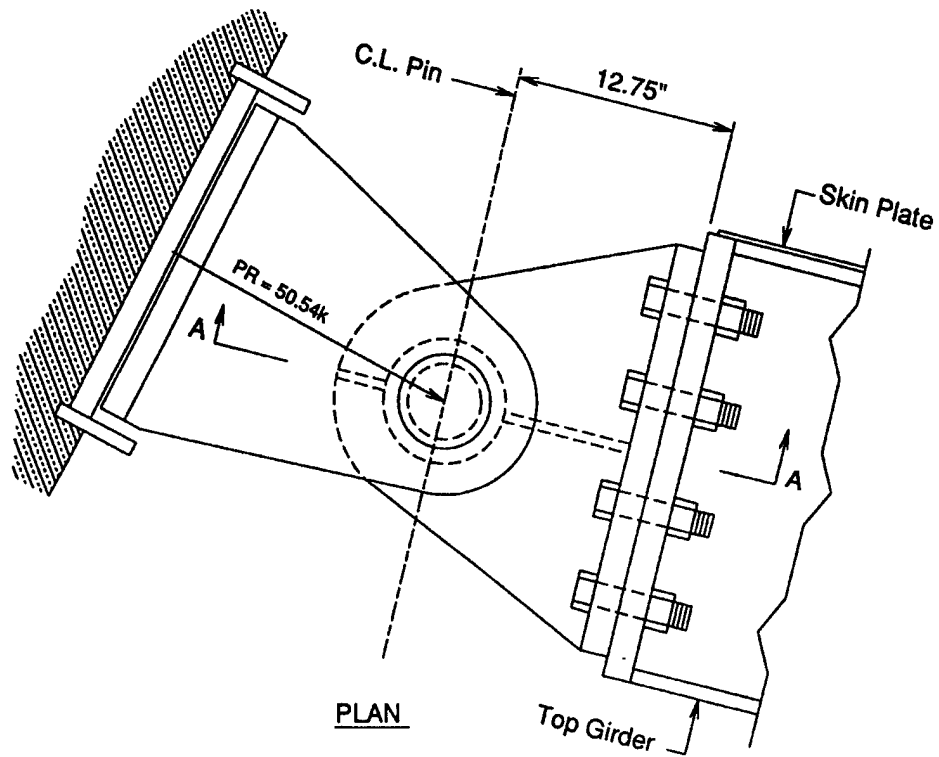

TOP PIN (Mat'l. ASTM A276, Fy = 55ksi)

$$P_R = 50.54k, V = 50.54/2 = 25.27k \text{ (Dbl. Shear)}$$

$$M = 50.54 \times 8.75/4 = 110.56k\text{-in}$$

$$A = 3.1416(4)^2/4 = 12.57, S = 3.1416(4)^3/32 = 6.28$$

$$F_b = 1.11(0.75F_y) = 45.83\text{ksi}$$

$$F_v = 1.11(0.4F_y) = 24.44\text{ksi}$$

$$f_v = 25.27/12.57 = 2.01\text{ksi} < 24.44\text{ksi}$$

$$f_b = 110.56/6.28 = 17.61\text{ksi} < 45.83\text{ksi}$$

TOP BUSHING (Mat'l. ASTM B22)

$$P_R = 50.54k, \text{ Bushing Length} = 6.00"$$

$$\text{Inside Dia.} = 4.00"$$

$$F_p = \text{Avg. Allowable Brg. Stress} = 1.11 \times 3.00 = 3.33\text{ksi}$$

$$f_p = 50.54/(4 \times 6) = 2.11\text{ksi} < 3.33\text{ksi}$$

CHECK MAX. BEARING STRESS:

$$R1 = 1.997", R2 = 2.001"$$

$$E1 = 29000\text{ksi}, E2 = 15000\text{ksi}$$

$$P1 = 50.54/6 = 8.42k/in$$

$$(\text{Max}) f_p = 0.591 \sqrt{\frac{8.42 \times 29 \times 15 \times 10^6 (2.001 - 1.997)}{(29 + 15)(10^3)(2.001 \times 1.997)}} = 5.396\text{ksi}$$

A Maximum Bearing Stress Equal To Or Less Than The Yield Strength Of The Material Is Allowable.

Appendix E Rolling Gate Design Example

The opening for the closure in this example is 60 ft wide by 9.63 ft high.

Load Cases:

In accordance with EM 1110-2-2502, consideration shall be given to load cases I1 through I4.

Case I1, Design Flood Loading. Gate is closed; water on the unprotected side is at the design flood elevation; water is at or below the sill surface on the protected side. When skin plate is on the unprotected side, stability against flotation shall be checked. Design stresses shall not exceed 5/6 of the stresses allowed in AISC (1989).

Case I2, Maximum Flood Loading. Same as case I1 except that water level is to top of gate on unprotected side. Design stresses shall not exceed 1.11 times the stresses allowed in AISC (1989).

Case I3, Earthquake Loading. This case is applicable to support structures only.

Case I4, Short-Duration Loading. Gate is in any position and is subjected to construction and/or wind loads. Design stresses shall not exceed 1.11 times the stresses allowed in AISC (1989).

In this example, cases I1 and I3 are not significant, and skin plate, intercostals, and girders are designed for case I2. Case I4 is applicable for design of latching devices and for checking overturning stability for wind loading.

The skin plate is designed as a fixed end member spanning between intercostals. In order to ensure that the flat plate theory is applicable, deflection will be limited to 0.4 of plate thickness.

The intercostals are designed as simple beams spanning between girders.

Girders are designed as simple beams spanning between bearing blocks on each side of the opening.

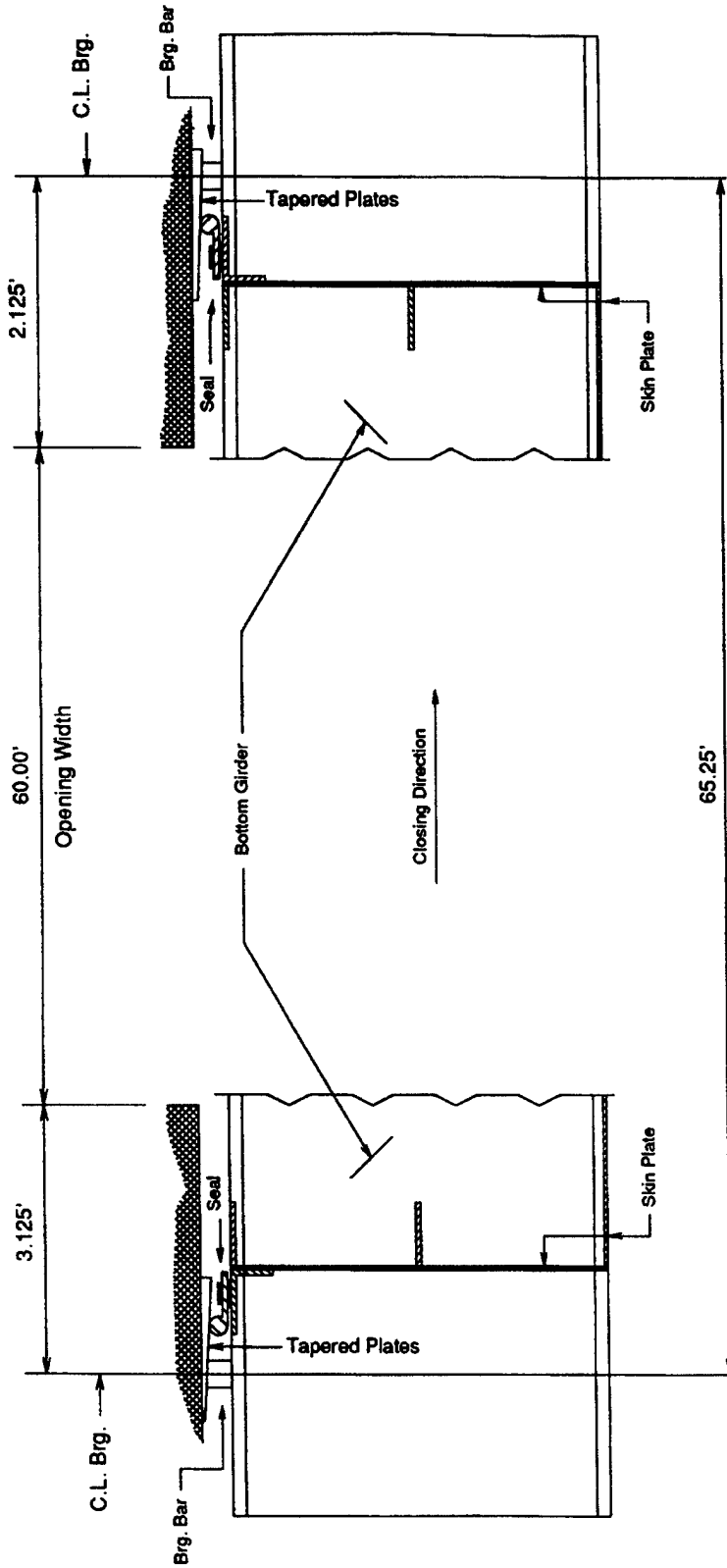

HORIZONTAL SECTION THRU GATE

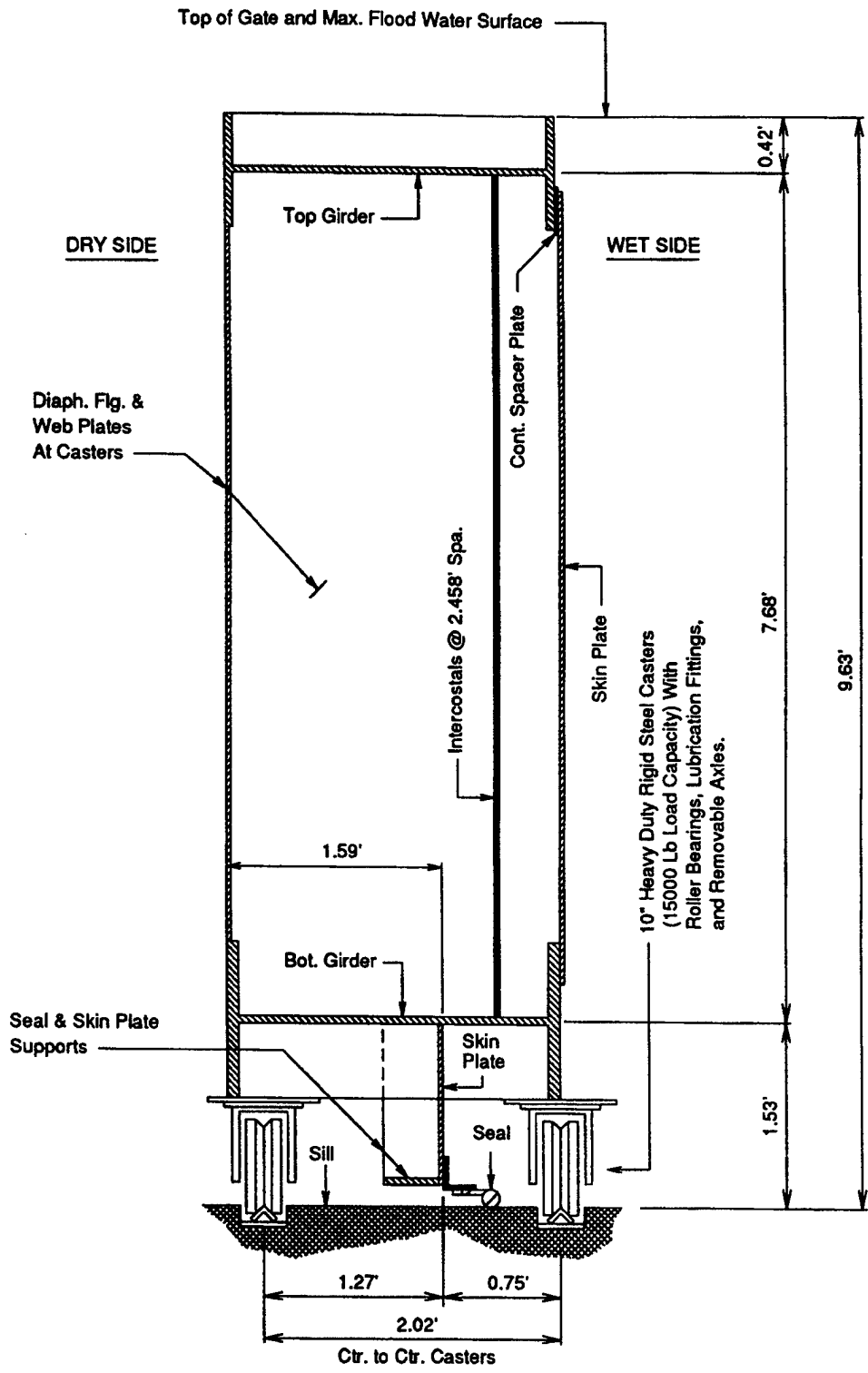

VERTICAL SECTION THRU GATE

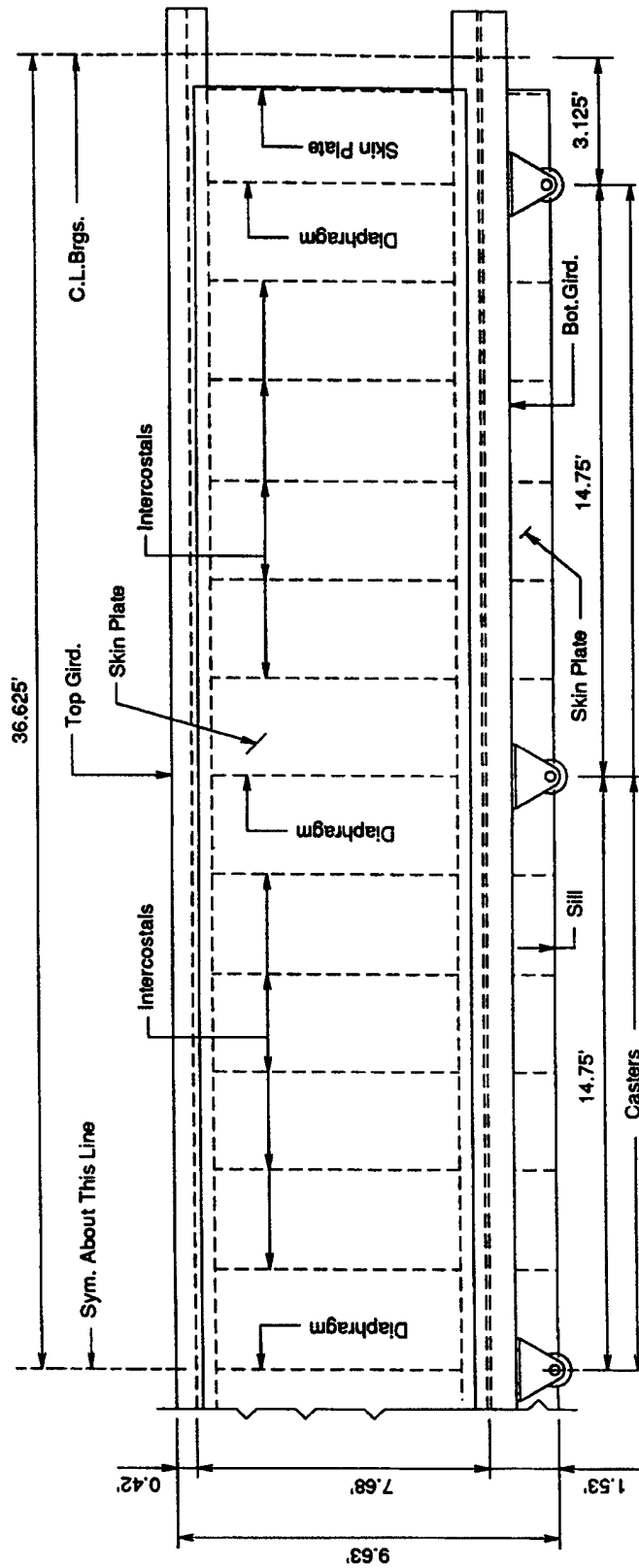

1/2 WET SIDE ELEVATION

GIRDER DESIGN (Mat'l. ASTM A36)

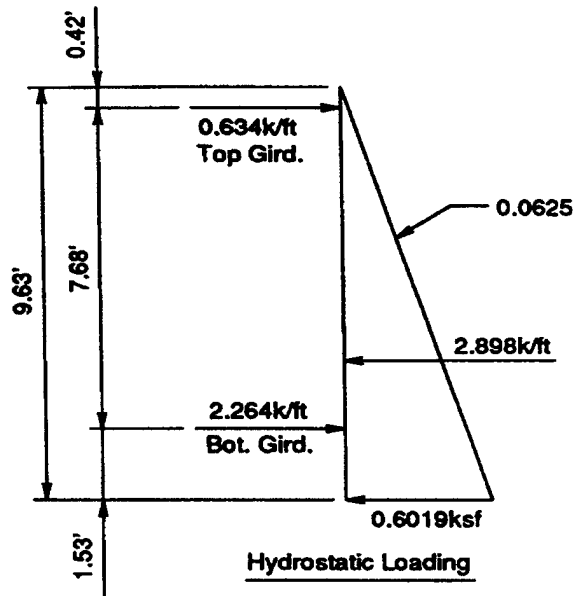

Bottom Girder:

Trial Section W27x194

$A=57$, $I=7820$, $S=556$

$W=2.264\text{k/ft}$

$L=65.25'$

$M=WL^2/8=1204.89\text{k-ft}$

$M=14458.68\text{k-in}$

Since compression

flange is braced

continuously and

compact section

requirements of

Table B5.1 of AISC (1989).

are satisfied, the

allowable bending

stress is:

$$F_b = 1.11(2/3)F_y = 26.67\text{ksi}$$

$$f_b = M/S = 14458.68/556 = 26.00\text{ksi} < F_b = 26.67\text{ksi}$$

USE: W27x194 FOR BOTTOM GIRDER

Top Girder:

Trial Section W27x84, $A=24.8$, $I=2850$, $S=213$

$W=0.634\text{k/ft}$, $L=65.25'$, $M=0.634(65.25)^2/8=337.41\text{k-ft}$

$M=4048.94\text{k-in}$

$$f_b = M/S = 4048.94/213 = 19.01\text{ksi} < F_b = 26.67\text{ksi}$$

USE: W27x84 FOR TOP GIRDER

SKIN PLATE DESIGN (Mat'l. ASTM A36)

p (6" above girder flg.) = $0.0625(9.63-1.53-0.58-0.5) = 0.439\text{ksf}$

$p = 0.00305\text{ksi}$, $L = 2.458' = 29.5"$, $M = pL^2 / 12 = 0.221\text{k-in}$

$F_b = 1.11(0.75)F_y = 30\text{ksi}$

$t_{\text{min for stress}} = (6M/F_b)^{0.5} = (6 \times 0.221 / 30.0)^{0.5} = \underline{0.2102"}$

$t_{\text{min for defl}} = (pL^4 / 12.8E)^{0.25}$

$t_{\text{min for defl}} = [0.00305(29.5)^4 / (12.8 \times 29000)]^{0.25} = \underline{0.2809"}$

USE 5/16" SKIN PLATE

INTERCOSTAL DESIGN (Mat'l. ASTM A36)

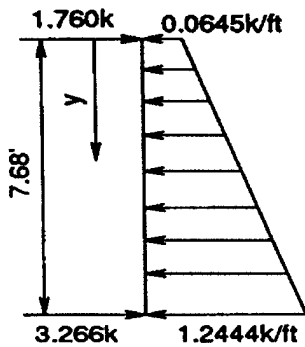

Hydrostatic
Loading

$M_y = 1.76 y - 0.03225 y^2 - 0.025605 y^3$

$V_y = 1.760 - 0.0645y - 0.0768y^2$

$V_y = 0$ and M_y is maximum at $y = 4.386'$

$M_{\text{max}} = 4.939\text{k-ft} = 59.27\text{k-in}$

Trial Section WT7x13, $S = 3.31$

$f_b = M/S = 59.27 / 3.31 = 17.91\text{ksi}$

$F_b = 1.11(0.6)F_y = 24\text{ksi} > 17.91\text{ksi}$

The WT7x13 is able to support the load without considering the contribution of the skin plate.

USE WT7x13 FOR INTERCOSTALS

CHECK RESISTANCE TO FLOTATION

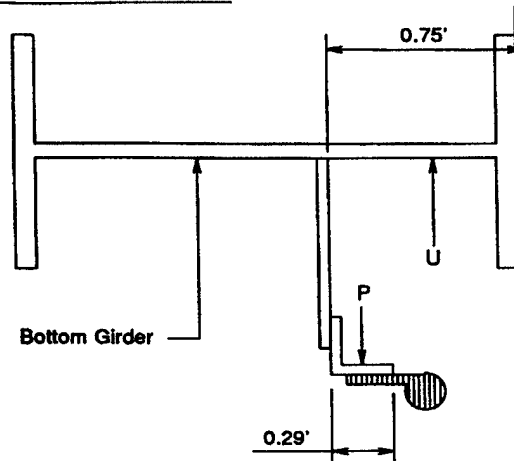

$U = 0.75(0.0625)(8.16) = 0.3825 \text{ k/ft}$, $W = \text{Wt. of Gate} = 0.4200 \text{ k/ft}$

$P = 0.29(0.0625)(9.44) = 0.1711 \text{ k/ft}$, $FS = \text{Factor of Safety}$

$FS = (W+P)/U = (0.4200 + 0.1711) / 0.3825 = 1.55$

Factor of Safety Req'd. by Ref. 3.a.(6). = 1.5

$FS = 1.55 > 1.5$ o.k.

CHECK WIND LOAD STABILITY

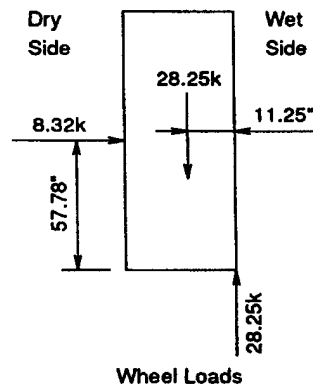

Assume gate is closed, but unlatched,
and subjected to a 75-MPH wind load.
Wind Pressure = $0.00256(75)^2 = 14.4 \text{ psf}$
Wind Load = $0.0144(60)(9.63) = 8.32 \text{ k}$
Gate Weight = 28.25k

$FS(\text{overturn}) = 28.25 \times 11.25 / (8.32 \times 57.78)$

$FS = 0.66 < 1.00$

Gate Must Be Latched To Withstand
A 75-MPH Wind.

GATE MUST ALWAYS BE LATCHED WHEN IN CLOSED POSITION

Appendix F Trolley Gate Design Example

The opening for the closure in this example is 32 ft wide by 24.5 ft high.

Load Cases:

Load cases used are for inland floodwalls in accordance with EM 1110-2-2502. Load case I1 was found to be critical for design of the lower girder and the skin plate. Load case I2 was found to be critical for design of the top girder and the intercostals. The maximum wind speed that may be allowed when the gate is not in a latched condition was calculated; this is a short-duration load similar to Case I4. The Trolley Rail Support Beam was designed for the stresses allowed in AISC (1989), with the total deflection limited to 1/700 of the span.

Case I1, Design Flood Loading. Gate is closed; water on the unprotected side is at the design flood elevation (in

this example 3 ft below top of gate); water is at or below sill surface on the protected side. Design stresses shall not exceed 5/6 of the stresses allowed in AISC (1989).

Case I2, Maximum Flood Loading. Same as case I1 except that water level is to top of gate on unprotected side. Design stresses shall not be greater than 1.11 times the stresses allowed in AISC (1989).

The skin plate is designed as a fixed end beam, spanning between intercostals. In order to ensure that the flat plate theory is applicable, deflection is limited to 0.4 of thickness.

The intercostals are designed as simple beams spanning between girders.

Girders are designed as simple beams spanning between bearings on each side of the opening.

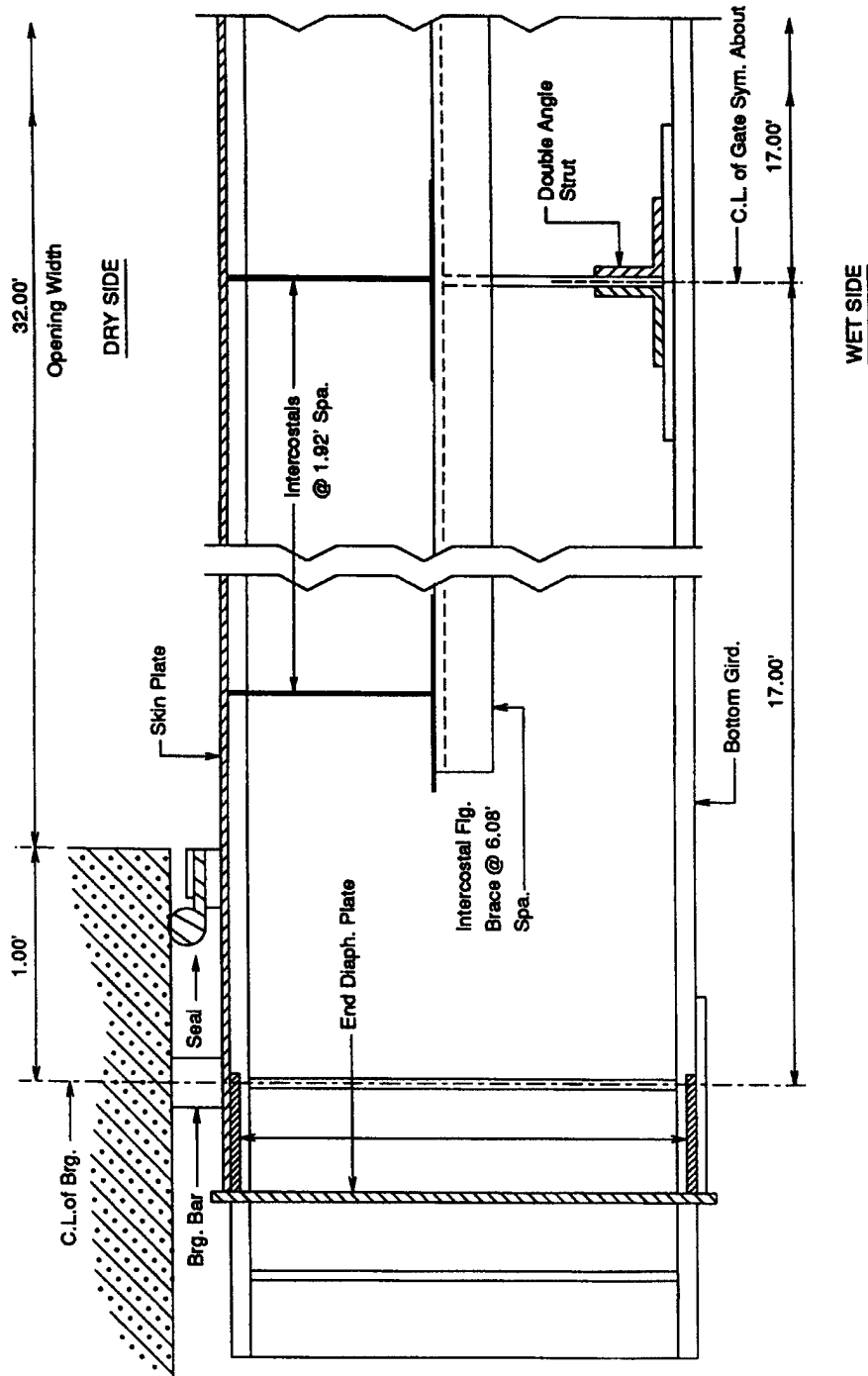

1/2 HORIZONTAL SECTION THRU GATE

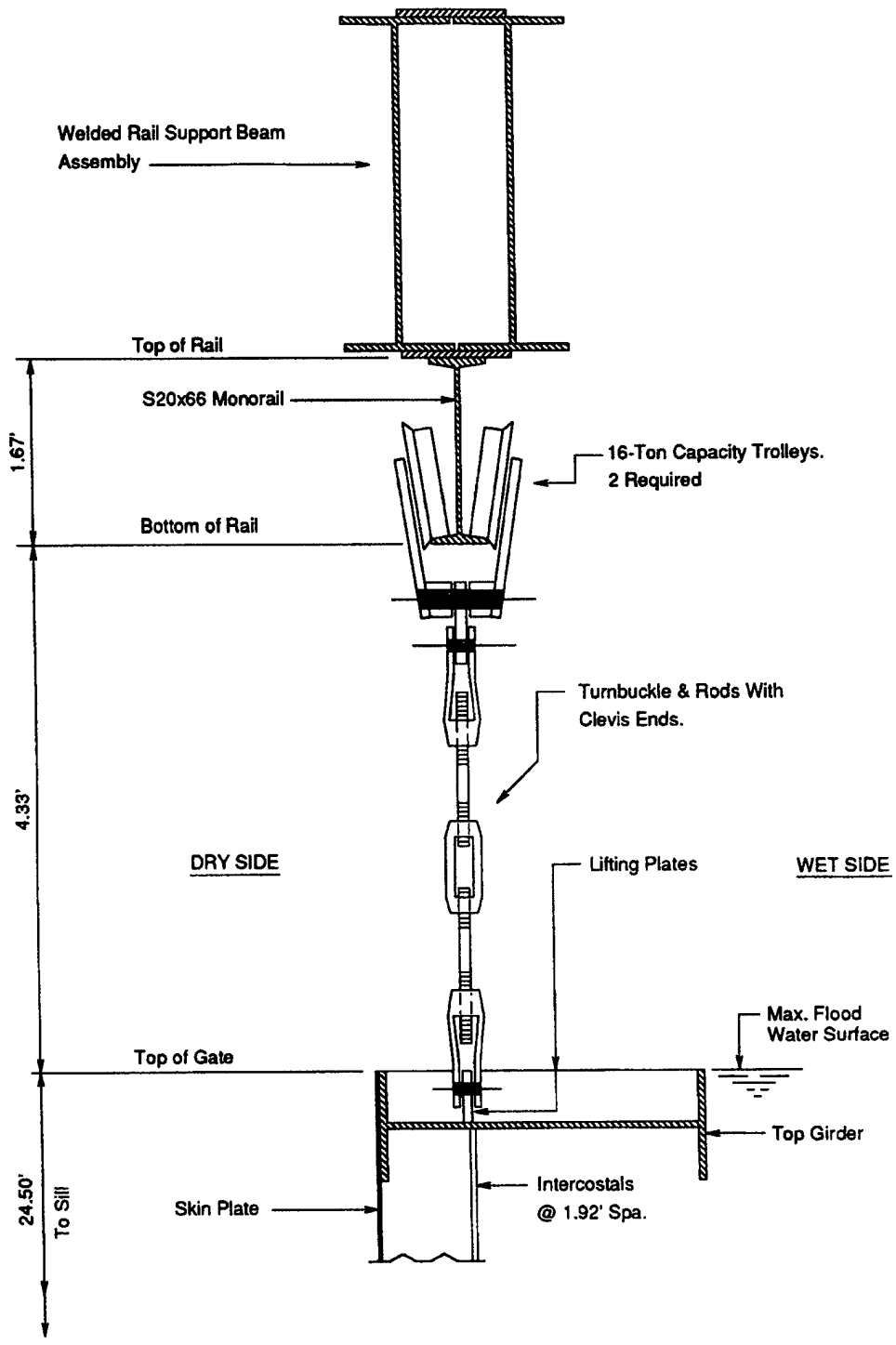

VERTICAL SECTION THRU TOP OF GATE
AND TROLLEY SUPPORT

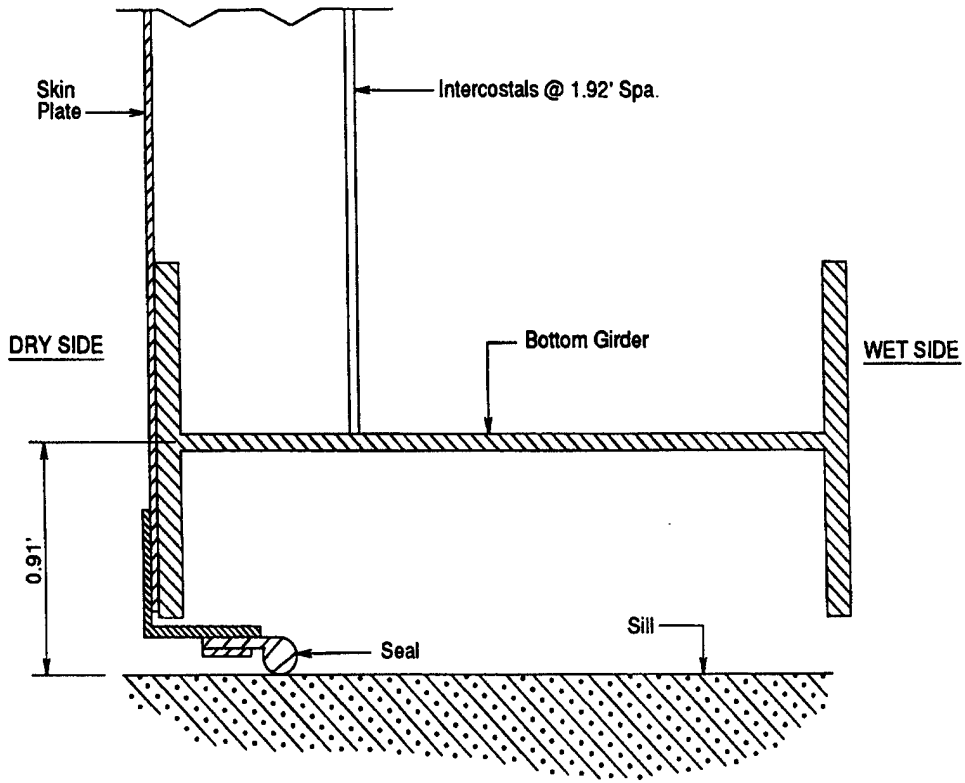

VERTICAL SECTION THRU BOTTOM GIRDER

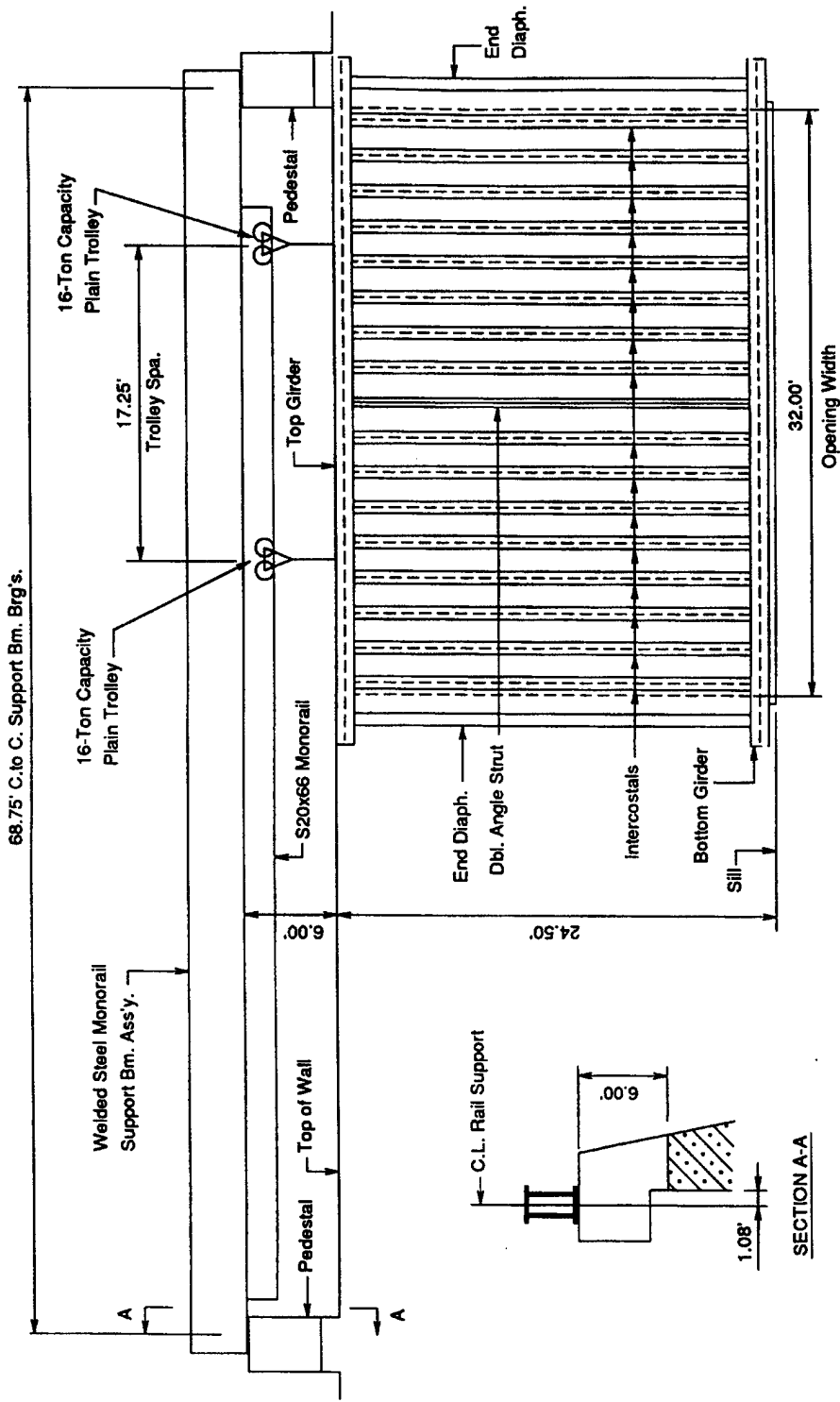

WET SIDE ELEVATION

GIRDER DESIGN

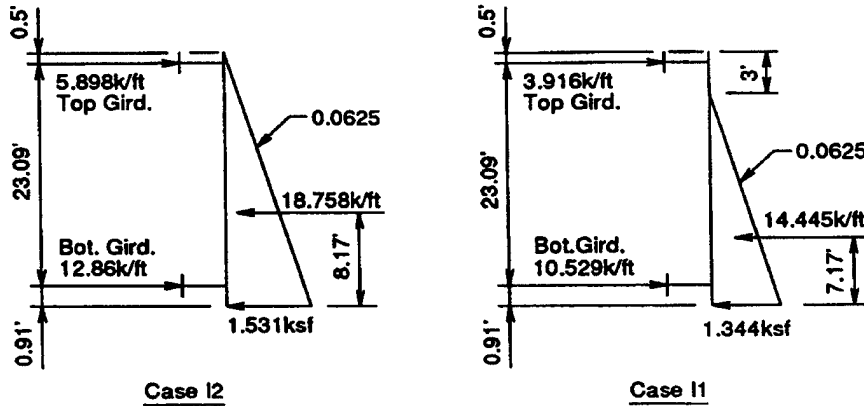

Girder Loadings

By inspection of the above loadings, design of the bottom girder is governed by Case I1 and design of the top girder is controlled by Case I2.

BOTTOM GIRDER: Eq. & Table No's. Are From AISC (1989).

Material ASTM A572-Gr.50, Trial Section W36x230: $S=837$, $r_T=4.3$

$$b_f = 16.50", L_b = 17' = 204", F_y = 50\text{ksi}, L_c = 76(16.50)/(50)^{1/2} \quad (F1-2)$$

$$L_c = 177.34" < L_b = 204", L_b / r_T = 47.44$$

$$F_b = [2/3 - 50(47.44)^2 / (1530 \times 10^3)] 50 \times 5/6 = 24.72\text{ksi} \quad (F1-6)$$

$$M = 10.529(34)^2 / 8 = 1521.44\text{k-ft} = 18257.28\text{k-in}$$

$$f_b = M/S = 18257.28/837 = 21.81\text{ksi} < 24.72\text{ksi}$$

USE W36x230 FOR BOTTOM GIRDER, A572-GR.50 STEEL

TOP GIRDER: Eq. & Table No's. Are From AISC (1989).

Material ASTM A572-Gr.50, Trial Section W36x135: $S=439$, $r_T=2.93$

$$b_f = 12", L_b = 204", L_c = 76b_f / (F_y)^{1/2} = 129 < 204 \quad (F1-2)$$

$$L_b / r_T = 69.62$$

$$F_b = [2/3 - 50(69.62)^2 / (1530 \times 10^3)] 50 \times 1.11 = 28.21\text{ksi} \quad (F1-6)$$

$$M = 5.898(34)^2 / 8 = 852.26\text{k-ft} = 10227.1\text{k-in}$$

$$f_b = M/S = 10227.1/439 = 23.30\text{ksi} < 28.21\text{ksi}$$

USE W36x135 FOR TOP GIRDER, ASTM A572-GR.50 STEEL

SKIN PLATE

p=water pressure 6" above bottom girder flange.

Skin plate stresses are critical for Case I1

$$p=0.0625(21.5-0.91-8.25/12-0.5)=1.213\text{ksf}=0.00842\text{ksi}$$

$$L=1.92'=23", M=pL^2/12=0.00842(23)^2/12=0.3712\text{k-in}$$

$$F_b=(5/6)(3/4)36=22.50\text{ksi}, t_{\text{min-stress}}=(6M/F_b)^{1/2}$$

$$t_{\text{min-stress}}=(6 \times 0.3712/22.5)^{1/2}=0.3146"$$

Maximum deflection will occur under Case I2.

$$p=0.0625(24.5-0.91-8.25/12-0.5)=1.400\text{ksf}=0.00972\text{ksi}$$

$$\text{For deflection equal to } 0.4t, t_{\text{min-defl}}=(pL^4/12.8E)^{1/4}$$

$$t_{\text{min-defl}}=[0.00972(23)^4/(12.8 \times 29000)]^{1/4}=0.2926"$$

USE 3/8" SKIN PLATE, ASTM A36

INTERCOSTALS

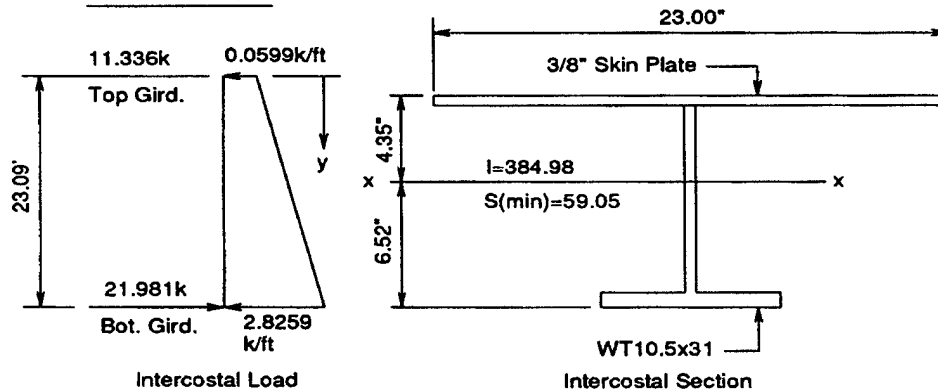

Intercostal Stresses Are Critical For Case I2.

$$M_y = 11.336y - 0.0300y^2 - 0.02y^3, M_y \text{ is maximum at } y=13.26'$$

$$M_{\text{max}} = 98.41\text{k-ft} = 1180.92\text{k-in}$$

$$L_b = 6.08' = 73", L_c = 76b_f / (F_y)^{1/2} = 104.37" > 73" \quad (F1-2)$$

$$\text{Section is compact. } F_b = 1.11(2/3)F_y = 1.11(2/3)(36) = 26.67\text{ksi}$$

$$f_b = M/S = 1180.92/59.05 = 20.00\text{ksi} < 26.67\text{ksi}$$

USE WT10.5x31 INTERCOSTALS, ASTM A36

MONORAIL SUPPORT BEAM

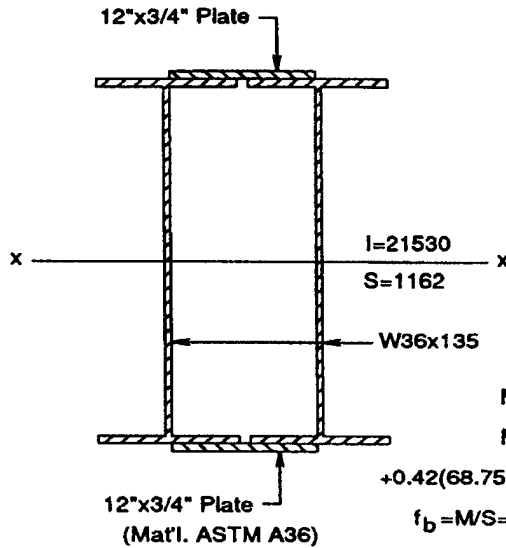

Gate Wt.=49k
 P=Trolley Load=49/2=24.5k
 I=Impact=P/4=6.125k
 P+I=30.625k
 W=Wt. Supp't. Bm. & Rail=0.42k/ft
 L=Span =68.75'
 a=Trolley Spacing=17.25'

$$M=(P+I)(L-a/2)^2 / (2xL) + WL^2 / 8$$

$$M=30.625(68.75-8.625)^2 / 137.5$$

$$+0.42(68.75)^2 / 8 = 1053.33k-ft = 12640k-in$$

$$f_b = M/S = 12640 / 1162 = 10.88ksi \quad \text{o.k.}$$

understressed

Rail Support Section

CHECK DEFLECTION:

L=68.75'=825", a=17.25'=207", W=0.42k/ft=0.035k/in

$$\text{Live Load Defl.} = \Delta_{LL} = P(L^3 - 3a^2L + 2a^3) / 24EI$$

$$\Delta_{LL} = 24.5[(825)^3 - 3(207)^2(825) + 2(207)^3] / (24 \times 29000 \times 21530) = 0.774"$$

$$\Delta_{LL}/L = 0.774/825 = 1/1066 < 1/1000 \quad \text{o.k.}$$

$$\text{Total Defl.} = 0.774" + 5WL / 384EI^4 = \Delta_T$$

$$\Delta_T = 5(0.035)(825)^4 / (384 \times 29000 \times 21530) + 0.774" = 1.112"$$

$$\Delta_T/L = 1.112/825 = 1/742 < 1/700 \quad \text{o.k.}$$

Size of Section is Controlled By Deflection.

USE 2-W36x135 With 12"x3/4" Plate Top & Bottom

CAMBER BEAM FOR TOTAL DEFLECTION

GATE HANGERS

$P+I=30.625k$

Use 1.50" Dia. Rods with 2" Dia. Upset Threaded Ends, Number
5 Clevises with 2" Dia. Pins, and Standard Turnbuckles.

Material: ASTM A36.

Safe Load For Clevises= $37.5k > 30.625k$

Safe Load For Turnbuckles= $37.2k > 30.625k$

ROD TENSION:

A_R =Cross Sectional Area of Rod= 1.767

A_T =Cross Sectional Area at Threads= 2.50

F_t =Allowable Tension= $18ksi$

f_t (rod)= $30.625/1.767=17.33ksi < 18ksi$

f_t (thread)= $30.625/2.50=12.25ksi$

Note: The maximum angle (from vertical) that the gate may rotate without inducing moment in the hangers is 2.8624 degrees. This is determined from the tolerances between the clevis and the lifting plate at the top of the gate.

W =Weight of Gate= $49k$, P =Horizontal Wind Load.

Y_p =Distance below clevis to line of action of wind load. = $12.0'$

Y_w =Distance below clevis of gate C.G.= $12.73'$

A_o =Gate opening area= $32 \times 24.5=784$ Sq.Ft.

X =Horizontal displacement of gate C.G.= $Y_w \sin(2.8624)=0.6357'$

p =Wind load= $0.00256V^2$, V =Wind speed in MPH.

P =Wind load= $pA_o =WX/Y_p =49000(0.6357)/12.00=2595.78$

$p=2595.78/A_o =3.311$ psf

$V^2 =p/0.00256=3.311/0.00256=1293.36$, $V=35.96$ MPH.

This indicates that gate must be latched in position for wind speeds in excess of 35MPH.

GATE MUST ALWAYS BE LATCHED WHEN IN CLOSED POSITION