

**DEPARTMENT OF THE ARMY
U.S. Army Corps of Engineers
Washington, DC 20314-1000**

ETL 1110-1-185

CECW-EG

Technical Letter
No. 1110-1-185

1 February 1999

**EXPIRES 31 December 2003
Engineering and Design
GUIDELINES ON GROUND IMPROVEMENT
FOR STRUCTURES AND FACILITIES**

1. Purpose

The purpose of this Engineer Technical Letter (ETL) is to provide guidance on ground improvement for USACE civil works and military programs projects. The enclosed document (Appendix A) contains an up-to-date overview of ground improvement techniques and related considerations. It addresses general evaluation of site and soil conditions, selection of improvement methods, preliminary cost estimating, design, construction, and performance evaluation for ground improvement. This document should be used as a resource during planning, design, and construction for new projects as well as a reference to guide more detailed design efforts for modification of our aging inventory of existing projects, particularly embankment dams. The use of such state-of-the-practice techniques is in keeping with good engineering practice and provides better service to our customers in concert with the USACE Strategic Vision.

2. Applicability

This ETL applies to all USACE Commands having civil works and military programs responsibilities.

3. Distribution

Approved for public release, distribution is unlimited.

4. Background

Ground improvement, in the context of this guidance, is the modification of existing site foundation soils or project earth structures to provide better performance under design and/or operational loading conditions. Ground improvement techniques are used increasingly for new projects to allow utilization of sites with poor subsurface conditions and to allow design and construction of needed projects despite poor subsurface conditions which formerly would have rendered the project economically unjustifiable or technically not feasible. More importantly, such techniques are used to permit continued safe and efficient operation of existing projects

DISTRIBUTION STATEMENT A
Approved for Public Release
Distribution Unlimited

20020708 115

ETL 1110-1-185
1 Feb 99

when major deficiencies become evident or where existing projects are likely to be subjected to loads greater than original design or as-built capabilities.

FOR THE COMMANDER:

A handwritten signature in black ink, appearing to read "Carl F. Enson". The signature is fluid and cursive, with a long horizontal stroke extending to the right.

CARL F. ENSON
Chief, Engineering Division
Directorate of Civil Works

APPENDIX A TABLE OF CONTENTS

Chapter	Title	Page
1	INTRODUCTION	1
2	IS GROUND IMPROVEMENT NECESSARY?	6
	Preliminary Evaluation	6
	Difficult Soils Evaluation	8
	Liquefaction Evaluation	9
	Stability Evaluation	11
	Bearing Capacity and Settlement Evaluation	13
	Seepage Evaluation	14
3	IF GROUND IMPROVEMENT IS NECESSARY, WHAT METHODS ARE AVAILABLE?	47
	Soil Replacement	49
	Admixture Stabilization.....	50
	Roller Compacted Concrete.....	50
	Deep Dynamic Compaction.....	50
	Vibrocompaction and Vibrorod.....	52
	Stone Columns (Vibroreplacement).....	54
	Gravel Drains.....	54
	Sand and Gravel Compaction Piles.....	56
	Explosive Compaction	57
	Permeation Grouting	58
	Compaction Grouting	59
	Jet Grouting	60
	Deep Soil Mixing	61
	Mini-Piles.....	61
	Soil Nailing.....	63
	Prefabricated Vertical Drains	64
	Electroosmosis	65
	Buttress Fills	66
	Biotechnical Stabilization and Soil Bioengineering	67
4	HOW IS GROUND IMPROVEMENT DESIGNED?	79
	Design Considerations and Parameters.....	79
	Design Procedures.....	81
	Design Issues	83
	Design Recommendations	85

TABLE OF CONTENTS (Cont.)

Chapter	Title	Page
5	WHAT ARE QA/QC REQUIREMENTS FOR IMPROVED GROUND?	89
	Construction Observations	89
	Verification Testing	92
	Laboratory Testing.....	94
6	WHAT HAS BEEN THE PERFORMANCE OF IMPROVED GROUND?	96
	ACKNOWLEDGMENTS	100
	REFERENCES	101

List of Tables

1	Potential Applications of Ground Improvement Methods in Civil Engineering	3
2	Flow Charts for Determination of the Need for Ground Improvement	15
3	Potentially Applicable Ground Improvement Methods for Civil Works Structures	68
4	Summary of Ground Improvement Methods for Remediation of Large, Open, Undeveloped Sites.....	70
5	Summary of Ground Improvement Methods for Remediation of Constrained and/or Developed Sites.....	74
6	Summary of Approximate Costs for Various Ground Improvement Methods	76

TABLE OF CONTENTS (Cont.)

List of Figures (Cont.)		Page
1 - 26	Refer to Table 2	15
27	Applicable grain size ranges for ground improvement methods	48
28	The dynamic compaction process	51
29	The vibrocompaction process	52
30	Range of particle size distributions suitable for densification by vibrocompaction	53
31	Approximate variation of relative density with tributary area or area replacement ratio	53
32	Arrangement of gravel drains	55
33	Usual compaction pile patterns	56
34	Typical layout for explosive compaction program	57
35	Types of grouting	59
36	Compaction grout bulb construction	60
37	The jet grouting process	61
38	DSM for liquefaction control	62
39	Mini-pile applications	62
40	Soil nailing for excavation support	63
41	PV drains with surcharge load	65
42	Buttress fill at toe of embankment	66
43	Biotechnical stabilization by brush layering	67
44	Effect of ground improvement on liquefaction potential for sites that were shaken in the 1989 Loma Prieta and 1995 Hyogo-ken Nambu (Kobe) earthquakes	88
45	Measured settlement at improved sites due to the 1995 Hyogo-ken Nambu (Kobe) earthquake	99

CHAPTER 1 INTRODUCTION

The purpose of this document is to provide engineering guidelines for ground improvement for the U.S. Army Corps of Engineers' structures and facilities. It includes essential elements needed for (1) general evaluation of site and soil conditions, (2) selection of improvement methods, (3) preliminary cost estimating, (4) design, (5) construction and (6) performance evaluation for ground improvement. The facilities covered include dams and their appurtenant structures, levees, locks, waterways, structures and tanks, dredged material containment structures, airfields, roadways, buildings, and other special-purpose structures.

The focus of the document is on practical application of recent and rapidly developing methods of ground improvement. Ground improvement for both new and existing structures and facilities is considered. Ground modification for seismic remediation and for correction of hydraulic deficiencies of existing dams and levees are major considerations because of the current COE emphasis on these projects.

There is special focus on how to select, design, specify, and evaluate ground improvement for specific purposes. Guidelines are given for determination if ground improvement is necessary, the level of improvement needed, the magnitude of improvement attainable by different methods, the required depth and areal extent of treatment, configuration of treatment zones, and methods for assessing the effectiveness of treatment. Methods for analysis of stability and deformation under static and dynamic loading are outlined.

Many potential applications of ground improvement for structures are given in Table 1. The table is organized according to types of facilities and their components. Levees are included as a separate category because, while they are similar in some ways to dams, many levees have been constructed of poor quality materials, without careful design or construction control, and in stages over long periods of time.

ETL 1110-1-185

1 Feb 99

Although this document contains recommendations, flow charts, and suggested procedures, it is not intended to be a design manual. Rather, its purposes are to identify key considerations for use of ground improvement, to suggest logical paths forward in a project, to provide guidance for design and construction, and to identify sources of useful information.

Table 1 - Potential Applications Of Ground Improvement Methods In Structures

Type Of Facility	Component	Potential Application
Embankment Dams	Dam	<ul style="list-style-type: none"> • Increase resistance to liquefaction, cracking, deformation and/or differential settlement • Mitigate effects of excess deformation or differential settlement • Improve seepage barriers • Reduce settlement • Strengthen and/or seal interface between embankment and foundation or abutments • Stabilize dispersive clays • Increase erosion resistance to overtopping
	Abutments	<ul style="list-style-type: none"> • Reduce movements due to seismic activity • Reduce or eliminate seepage through joints or cracks in abutments • Strengthen and/or seal interface between abutment and embankment
	Foundation	<ul style="list-style-type: none"> • Increase resistance to liquefaction • Reduce movements due to settlement, solution cavities or seismic activity • Reduce settlement • Improve seepage barriers • Stabilize collapsing or expansive soils • Strengthen and/or seal interface between embankment and foundation
Levees	Levee	<ul style="list-style-type: none"> • Increase resistance to liquefaction, cracking, deformation and/or differential settlement • Improve seepage barriers • Reduce settlement • Stabilize dispersive clays
	Foundation	<ul style="list-style-type: none"> • Increase resistance to liquefaction • Reduce settlement • Improve seepage barriers • Stabilize dispersive, collapsing, or expansive soils

Table 1 (cont.) - Potential Applications Of Ground Improvement Methods In Structures

Type Of Facility	Component	Potential Application
Concrete or Masonry Dams	Abutments	<ul style="list-style-type: none"> • Reduce movements due to seismic activity • Reduce leakage through joints or cracks
	Foundation	<ul style="list-style-type: none"> • Increase liquefaction resistance • Reduce movements due to consolidation settlement, solution cavities or seismic activity • Improve seepage barriers • Stabilize dispersive, collapsing, or expansive soils
Appurtenant Structures to Dams	Spillway	<ul style="list-style-type: none"> • Improving erosion resistance of dam to overtopping • Increase resistance to erosion or undermining of spillway
	Outlet Works	<ul style="list-style-type: none"> • Stabilize the foundation for gates, valves or hoists that have experienced differential settlement • Seal leaking conduits, reduce piping along conduits • Increase erosion resistance
	Stilling Basin	
	Piping	<ul style="list-style-type: none"> • Limit differential settlement to prevent joint separation, structural cracking and/or piping
	Chamber	<ul style="list-style-type: none"> • Increase resistance to liquefaction, cracking, deformation and/or differential settlement • In support of reducing leakage through cracks • In support of reducing seepage to decrease water losses during periods of low water • Reduce movement due to settlement, solution cavities or seismic activity
Locks	Foundation	<ul style="list-style-type: none"> • Increase resistance to liquefaction • Reduce movement due to settlement, solution cavities or seismic activity • Reduce settlement • Reduce leakage through cracks

Table 1 (cont.) - Potential Applications Of Ground Improvement Methods In Structures

Type Of Facility	Component	Potential Application
Locks	Gates and Valves	<ul style="list-style-type: none"> • Stabilize the foundation for gates, valves or hoists that have experienced differential settlement • In support of sealing leaking conduits, reducing piping along conduits
Waterways	Canals, Lock Approach or Flood Control Channels	<ul style="list-style-type: none"> • Stabilize expansive soils, collapsing soils or dispersive clays • Disposal and containment of dredged material • Improve stability of slopes • Linings of stabilized soil
	Harbors	<ul style="list-style-type: none"> • Disposal and containment of dredged material • Improve stability of underwater slopes • Provide support and stability for quay walls • Prevent lateral spreading • Improve stability of breakwaters and their foundations
Other Structures (Buildings, Walls, Tanks)	Shallow Foundations (Footings, Mats)	<ul style="list-style-type: none"> • Increase resistance to liquefaction • Increase resistance to cracking, deformation and/or differential settlement • Reduce movement due to settlement, solution cavities or seismic activity • Stabilization of collapsing or expansive soils
	Deep Foundations (Piles, Piers, Caissons)	<ul style="list-style-type: none"> • Increase resistance to liquefaction to prevent loss of lateral support during seismic activity
	Underground Tanks	<ul style="list-style-type: none"> • Increase resistance to liquefaction to minimize loss of support or flotation of tanks
Dredged Material Disposal	Containment Structure	<ul style="list-style-type: none"> • Consolidation of compressible strata beneath containment area • Improve properties of poor foundation materials • Reduce settlement of containment dikes • Provide containment barriers for pollutants

CHAPTER 2

IS GROUND IMPROVEMENT NECESSARY?

A number of analyses and decisions may be required to determine if ground improvement is necessary. A series of flow charts to aid in this process are listed in Table 2 and included as Figures 1 through 26. Each level of analysis, which is represented by a single chart or a series of charts, requires progressively more detailed information. Figure 1 shows the overall evaluation process necessary to assess the need for ground improvement for a facility. Figure 2 can be used for a preliminary evaluation of site conditions and design/performance requirements. If, based on the results of the preliminary evaluation, more detailed analyses are required, Figures 3 through 8 are used. These charts include evaluations for difficult soils, liquefaction potential, slope stability, bearing capacity and settlement, and seepage instability. "Difficult soils" include collapsing soils, expansive soils, sensitive clays and dispersive clays. These soil types are discussed below under the heading "Difficult Soils Evaluation." The evaluations for difficult soils, bearing capacity and settlement, and seepage instability are complete after this step.

A further level of analysis could be required for liquefaction and slope stability evaluations. These analyses are performed to estimate deformations for situations where the factor of safety is inadequate. The steps necessary for gross deformation estimates are shown in Figures 9 and 10, while the procedure for refined deformation estimates is shown in Figure 11. Methods for determination of the properties and parameters listed in Figures 2 through 11 are described in Figures 12 through 26.

Preliminary Evaluation

The preliminary evaluation (Figure 2) can be performed for new or existing facilities. For the preliminary evaluation, project performance requirements need definition and site

characterization must be completed. The project performance requirements that pertain to the potential need for ground improvement include loading conditions and allowable deformations for the facility, as well as an assessment of the impacts of natural hazards, such as floods, earthquakes or hurricanes, and the performance required during these events. For a new facility, the performance requirements should be determined during the early stages of analysis and design. For an existing facility, the performance requirements may be the result of an upgrade in the facility or deficiencies requiring remedial work to improve performance during a flood or an earthquake. In addition, re-evaluations of hazards, such as earthquake magnitude, peak flood and sustained wind velocity, often lead to increased demands on structures and facilities so that retrofitting is required.

The site characterization step includes investigations to evaluate the soil profile, ground water levels and soil properties. New projects will likely require a detailed geotechnical investigation or series of investigations to obtain the information necessary to make ground improvement decisions. Guidelines for planning these studies are presented in EM 1110-1-1804, Geotechnical Investigations. The geotechnical investigations can be performed in stages, beginning with a preliminary subsurface investigation and proceeding to more detailed investigations as more specific and detailed information is required.

At existing facilities, old records, such as geotechnical investigation reports and boring logs, may provide sufficient information to make decisions regarding the need for ground improvement. However, it is likely that supplemental information or investigations will be necessary. Additional geotechnical investigations should be performed in accordance with EM 1110-1-1804.

All available information should be used to aid in the decision-making process. Regional geologic references can be consulted for general information about the soil composition, fabric and structure. Experience with similar soils or nearby sites can be used to provide guidance regarding the performance of a soil and the need for ground improvement. Boring log data from adjacent properties can provide information about the stratigraphy

and ground water conditions in the immediate vicinity of the site. Assessment methods for design/performance requirements and subsurface conditions are presented in Figures 12 through 16.

The information on the subsurface conditions should be used in conjunction with the project performance requirements to make a series of decisions regarding the need for further analysis. Further analysis is required if there is evidence of any of the following:

1. difficult soils, such as expansive or collapsing soil and sensitive or dispersive clay;
2. potential for liquefaction;
3. potential for slope instability;
4. inadequate bearing capacity or excessive settlement; and,
5. potential for excess seepage, high uplift pressures, or erosion and piping.

The flow chart in Figure 2 requires a "Yes" or "No" answer for each of the five items listed above. If the answer to one or more of the decisions is "Yes," then an additional evaluation for each item with a "Yes" response should be performed before a decision can be made regarding the need for ground improvement (or alternative corrective action). The additional evaluations are discussed below. If the answer to every one of the five decisions is "No," then ground improvement is not required and further evaluation is not necessary.

Difficult Soils Evaluation

Difficult soils are considered to be collapsing soils (e.g. loess, mud and debris flow deposits, hydraulic fills and tailings deposits), expansive soils, sensitive clays and dispersive clays. Collapsing soil deposits have a loose, collapsible structure. When saturated and disturbed, collapsing soils can undergo large decreases in volume or liquefy with sudden loss of strength. Expansive soils can also experience extreme volume changes, but for different reasons. While the low density soil structure is the primary reason for volume

change in collapsing soils, soil composition is the usual culprit in expansive soils. Most expansive soils contain smectite clays such as montmorillonite or bentonite. In the presence of water, these clays attract free water and swell; in the absence of water, the clays release free water and shrink. A detailed discussion of expansive soils is provided in Wray (1995).

Sensitive clays lose undrained strength when remolded. Sensitivity can be formed by a variety of factors, including metastable fabric, cementation, leaching, weathering, thixotropic hardening, and formation or addition of dispersing agents. Dispersive clays are highly erodible because the clay particle associations are structurally unstable and easily dispersed. The individual particles will spontaneously detach from each other and go into suspension in quiet water.

The steps necessary for difficult soils evaluation are listed in Figures 3 and 4. Assessment methods for soil state parameters are shown in Figure 17. If difficult soils are present at a site, the need for remedial action depends on the type of facility under consideration. Dispersive clays are a threat to dams and levees because they can initiate erosion and piping through the embankment or foundation that may lead to failure. Numerous canals in the west and southwest are constructed in collapsing soils or dispersive clay. Sensitive clays can be a concern for natural slopes. Collapsing and expansive soils may be more of a concern for structures with footings that could be exposed to water. Engineering judgment is required to make the final determination as to whether improvement of difficult soils is required.

Liquefaction Evaluation

Loose, saturated sands are susceptible to liquefaction or lateral spreading if subjected to earthquake motion. The development of excess pore water pressures and the subsequent loss of soil strength associated with liquefaction can result in ground settlement, lateral

spreading, and/or loss of foundation support. The potential liquefaction hazards at a site can be evaluated by considering the following questions:

1. Is the soil susceptible to liquefaction?
2. If the soil is susceptible, will liquefaction be triggered?
3. If liquefaction is triggered, will damage occur?

Figure 2 can be used to address the first question. If the answer to the liquefaction question in Figure 2 is "No," it can be concluded that a liquefaction hazard does not exist. If the answer to the liquefaction question in Figure 2 is "Yes," Figure 5 can be used to evaluate the liquefaction potential, which will address the second question. If the factor of safety against liquefaction is above 1.5 and the anticipated settlement is less than half the allowable amount, ground improvement is not required and the liquefaction analysis is complete. If the factor of safety against liquefaction is less than one and the anticipated settlement is more than twice the allowable amount, liquefaction will likely be triggered and the anticipated deformations may be too high. Ground improvement or other mitigation methods will be required. If the results of the analysis are between these limits, gross deformation estimates, which are outlined in Figure 9, are necessary before ground improvement decisions can be made.

The gross deformation estimates involve calculations to determine a bearing capacity factor of safety and the amount of settlement and lateral deformation anticipated. If the bearing capacity safety factor is greater than 1.2, and the anticipated settlement and lateral deformation are less than half the allowable vertical and horizontal movement, respectively, ground improvement is not required and the liquefaction analysis is complete. If the bearing capacity factor of safety is less than 0.8 or the anticipated settlement or lateral deformation is more than twice the allowable vertical or horizontal movement, respectively, it is likely that liquefaction will be triggered and the anticipated deformations will probably be too high. Ground improvement or other mitigation methods will be required. For major projects, if the results are between these limits, a refined deformation estimate may be warranted before ground improvement decisions can be made. The parameter as-

assessment methods required for the gross deformation estimates are summarized in Figure 22.

The refined deformation estimates require that settlement and lateral spreading be calculated using a dynamic deformation analysis. Figure 11 is a flowchart which outlines the steps necessary for a refined deformation analysis. Assessment methods for the parameters necessary for the refined deformation estimates are shown in Figures 24 through 26. If the results of the deformation analysis indicate that the anticipated lateral deformation or settlement are more than two-thirds the allowable, ground improvement or other mitigation methods will be required. Otherwise, ground improvement is not required. The liquefaction analysis is complete after this step.

Stability Evaluation

For dams, levees and slopes, stability evaluations will usually be required. The most common method for stability evaluation is a limit equilibrium analysis. Factors which must be considered in the analysis include static loading conditions, earthquake loading, soil and rock parameters, and site conditions. Figure 6 is a flowchart which outlines the factors and parameters required to perform a limit equilibrium stability analysis. Limit equilibrium slope stability analysis are discussed in EM-1110-2-1902, Stability of Earth and Rockfill Dams. Methods for assessing the parameters necessary for slope stability analyses are discussed in that manual. Parameter assessment methods are also summarized in Figure 20.

If the site is located in a seismically active area, a pseudostatic limit equilibrium analysis is the simplest and usually the first type of analysis used to consider the effects of seismically-induced motions. In a pseudostatic analysis, the earthquake shaking is represented by horizontal and vertical inertial forces applied at the centroid of the failure mass (Kramer, 1996). These forces, called pseudostatic forces, are calculated by multiplying the weight of the failure mass by vertical and horizontal pseudostatic coefficients. The effect of the pseudostatic forces on the factor of safety is then determined in a limit equi-

librium analysis. If the analysis results in a pseudostatic factor of safety less than that required for the particular facility, which is often 1.0, the slope is considered to be unstable. The vertical inertial forces usually have a negligible effect on the calculated factor of safety and are often ignored in the analysis.

The most important factor in performing a pseudostatic analysis is selection of the appropriate pseudostatic coefficient. The selection of the coefficient should be related to the anticipated ground motion in some way, because it controls the additional force applied to the failure mass. The value selected is often significantly less than the peak acceleration for two reasons. First, the duration of the peak acceleration is usually short. Also, applying an inertial force equal to the product of the horizontal acceleration and the potential sliding mass would be appropriate only for a rigid material. Since the slope can deform under earthquake loading, the applied force will be smaller than this (Kramer, 1996).

In selecting a pseudostatic coefficient for design, Kramer (1996) recommends that the coefficient correspond to some fraction of the anticipated peak acceleration. Since the pseudostatic method was first used, many studies have been performed to evaluate appropriate values for the pseudostatic coefficient (e.g. Terzaghi, 1950, Seed, 1979a, Marcu-son, 1981). Several of these studies are reviewed in Kramer (1996).

Hynes-Griffin and Franklin (1984) applied the Newmark sliding block analysis (Newmark, 1965) to over 350 accelerograms to predict permanent deformations using a yield acceleration and assuming a rigid slope material. The yield acceleration depends on the soil properties and the geometry of the slope. When the induced acceleration is greater than the yield acceleration, permanent deformation occurs along the failure plane. Hynes-Griffin and Franklin (1984) determined that "dangerously large" deformations would not develop in earth dams if the pseudostatic factors of safety is greater than 1.0 using $k_h = 0.5 a_{max}/g$. Kramer (1996) suggests that this criterion should be appropriate for most slopes, although engineering judgment is necessary in all cases.

If the factor of safety is found to be inadequate using the pseudostatic method, a detailed deformation analysis is required. A simplified method for estimating earthquake-induced deformations for dams and embankments was developed by Makdisi and Seed (1978). The method is based on the Newmark sliding block analysis, but accounts for the dynamic behavior of the embankment rather than assuming rigid body behavior. The method makes several simplifying assumptions, including: (1) failure occurs on a well-defined slip surface, (2) the soil behaves elastically at stress levels below failure, and (3) the soil behaves plastically at stress levels above the yield stress. The earthquake-induced accelerations are represented by average time histories calculated using dynamic response analyses.

The factors and parameters required to perform gross deformation estimates by the Makdisi-Seed method are outlined in Figure 10. The earthquake parameters required for the analysis are shown in Figure 15, while the soil parameters required are shown in Figure 23. Note that the procedure was developed for dams and embankments. Therefore, if it is used for other types of slopes, the results should be interpreted with caution.

If the results of the gross deformation analysis indicate that the anticipated displacement is tolerable, ground improvement is not required and the stability analysis is complete. However, if the anticipated displacement is greater than the allowable displacement, a refined deformation analysis will be required before ground improvement decisions can be made. The procedure for performing a refined deformation analysis was discussed above under the heading "Liquefaction Evaluation."

Bearing Capacity and Settlement Evaluation

For a new structure, a bearing capacity and settlement evaluation can be performed to determine if adequate bearing capacity is available and if estimated settlements will be in the permissible range. If the results of the evaluation indicate that the bearing capacity may be too low or that excessive settlements are likely, ground improvement may be one way to

solve the problem. For the case of a lightly loaded structure placed on a cohesive "crust" over a liquefiable layer, a simplified procedure has been developed by Naesgaard et al. (1998) to determine the factor of safety against bearing failure and to estimate the deformation of the foundation after liquefaction. If the factor of safety against bearing failure is adequate and the anticipated settlements are tolerable, it may not be necessary to improve the liquefiable layer. For existing facilities, if excessive settlement has occurred or there is evidence that the bearing capacity may be inadequate, ground improvement may be a suitable remedial measure. The procedures for the bearing capacity and settlement evaluation are outlined in Figure 7. The parameter assessment methods required for the evaluation are summarized in Figure 20.

Seepage Evaluation

A seepage evaluation will be required for all dams and levees. Ground improvement methods may have applications if the seepage quantity or uplift pressures are too high, or if the factor of safety against erosion and piping is too low. Figure 8 is a flow chart which outlines the factors and parameters necessary to perform the seepage evaluation. Assessment methods for the factors and parameters listed in Figure 8 are summarized in Figure 21.

Table 2 - Flow Charts for Determination of the Need for Ground Improvement

Figure	Title	Page
1	Evaluation of Site Conditions and Design/Performance Requirements to Assess Need for Ground Improvement	17
2	Preliminary Evaluation of Site Conditions and Design/Performance Requirements	18
3	Difficult Soils Evaluation – Collapsing or Expansive Soils	20
4	Difficult Soils Evaluation – Sensitive or Dispersive Clay	21
5	Evaluation of Liquefaction Potential	22
6	Slope Stability Evaluation	24
7	Bearing Capacity and Settlement Evaluation	25
8	Seepage Evaluation	26
9	Evaluation of Liquefaction Potential – Gross Deformation Estimates	27
10	Slope Stability Evaluation – Gross Deformation Estimates	29
11	Refined Deformation Estimates for Liquefaction and Slope Stability Evaluations	30
12	Assessment Methods for Soil Classification and Experience Parameters for Preliminary Evaluation of Site Conditions and Design/Performance Requirements	32
13	Assessment Methods for Boundary Condition Parameters for Preliminary Evaluation of Site Conditions and Design/Performance Requirements	33
14	Assessment Methods for Loading Conditions and Settlement Parameters for Preliminary Evaluation of Site Conditions and Design/Performance Requirements	34
15	Assessment Methods for Earthquake Characteristic Parameters for Preliminary Evaluation of Site Conditions and Design/Performance Requirements	35
16	Assessment Methods for Flood Parameters for Preliminary Evaluation of Site Conditions and Design/Performance Requirements	36
17	Assessment Methods for Soil State Parameters for Difficult Soils, Slope Stability, and Seepage Evaluations	37
18	Assessment Methods for Earthquake Loading and Liquefaction Resistance Parameters for Evaluation of Liquefaction Potential	38
19	Assessment Methods for Strength Properties for Slope Stability and Bearing Capacity Evaluation	39
20	Parameter Assessment Methods for Slope Stability, Bearing Capacity and Settlement Evaluations	40
21	Parameter Assessment Methods for Seepage Evaluation	41
22	Parameter Assessment Methods for Evaluation of Liquefaction Potential - Gross Deformation Estimates	42

Table 2 (cont.) - Flow Charts for Determination of the Need for Ground Improvement

Figure	Title	Page
23	Assessment Methods for Soil Parameters for Slope Stability Evaluation – Gross Deformation Estimates	43
24	Assessment Methods for Earthquake Loading and Stress State Properties for Refined Deformation Estimates for Liquefaction and Slope Stability Evaluations	44
25	Assessment Methods for Strength Properties for Refined Deformation Estimates for Liquefaction and Slope Stability Evaluations	45
26	Assessment Methods for Stiffness and Recompression Properties for Refined Deformation Estimates for Liquefaction and Slope Stability Evaluations	46

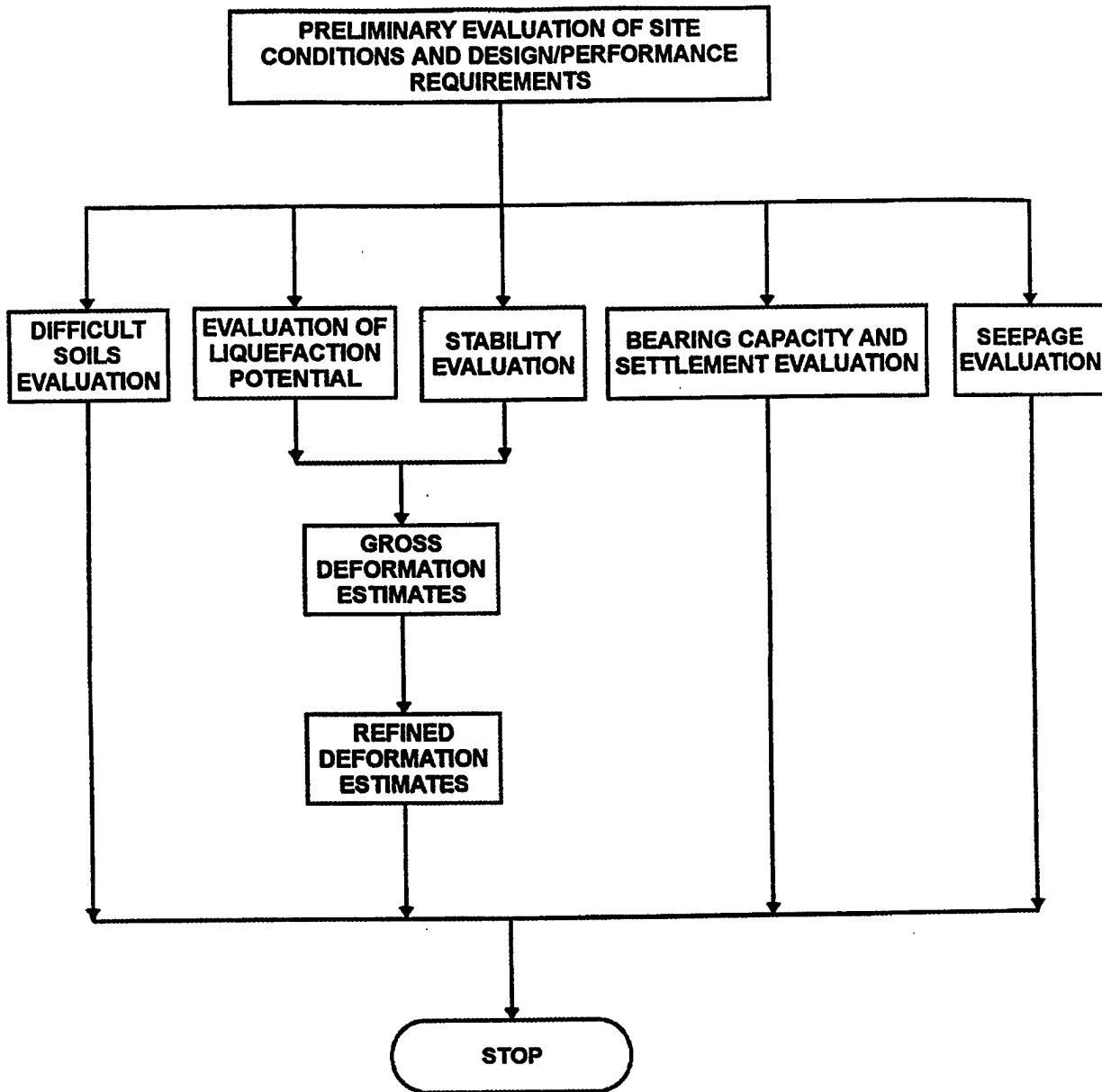

Notes:

1. The factors, relevant parameters, analytical methods, and decisions for each step are given in Figures 2 through 11.

FIGURE 1 Evaluation of Site Conditions and Design/Performance Requirements to Assess Need for Ground Improvement

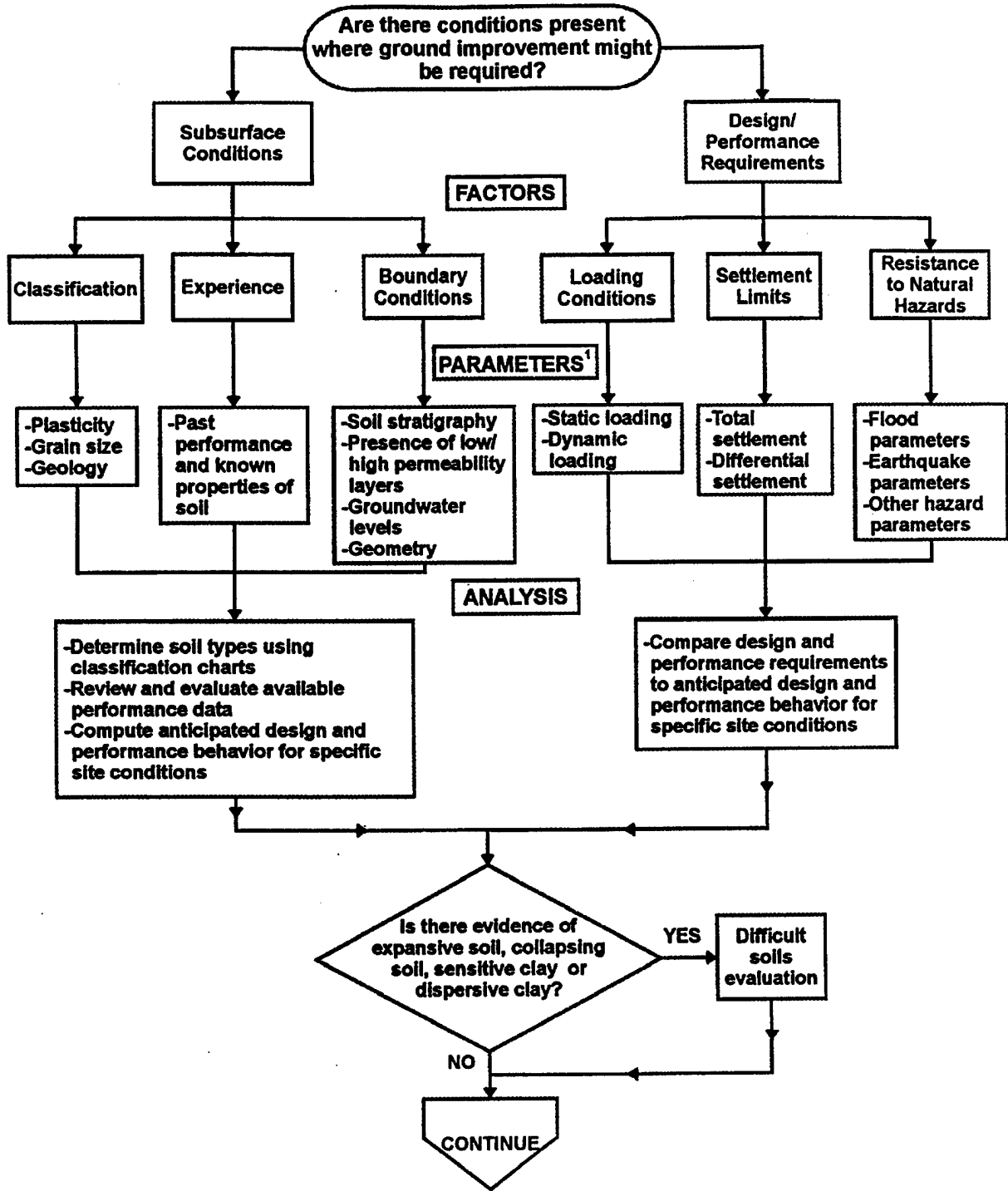

Notes:

1. Assessment methods for parameters are given in Figures 12 through 16.

FIGURE 2 Preliminary Evaluation of Site Conditions and Design/Performance Requirements

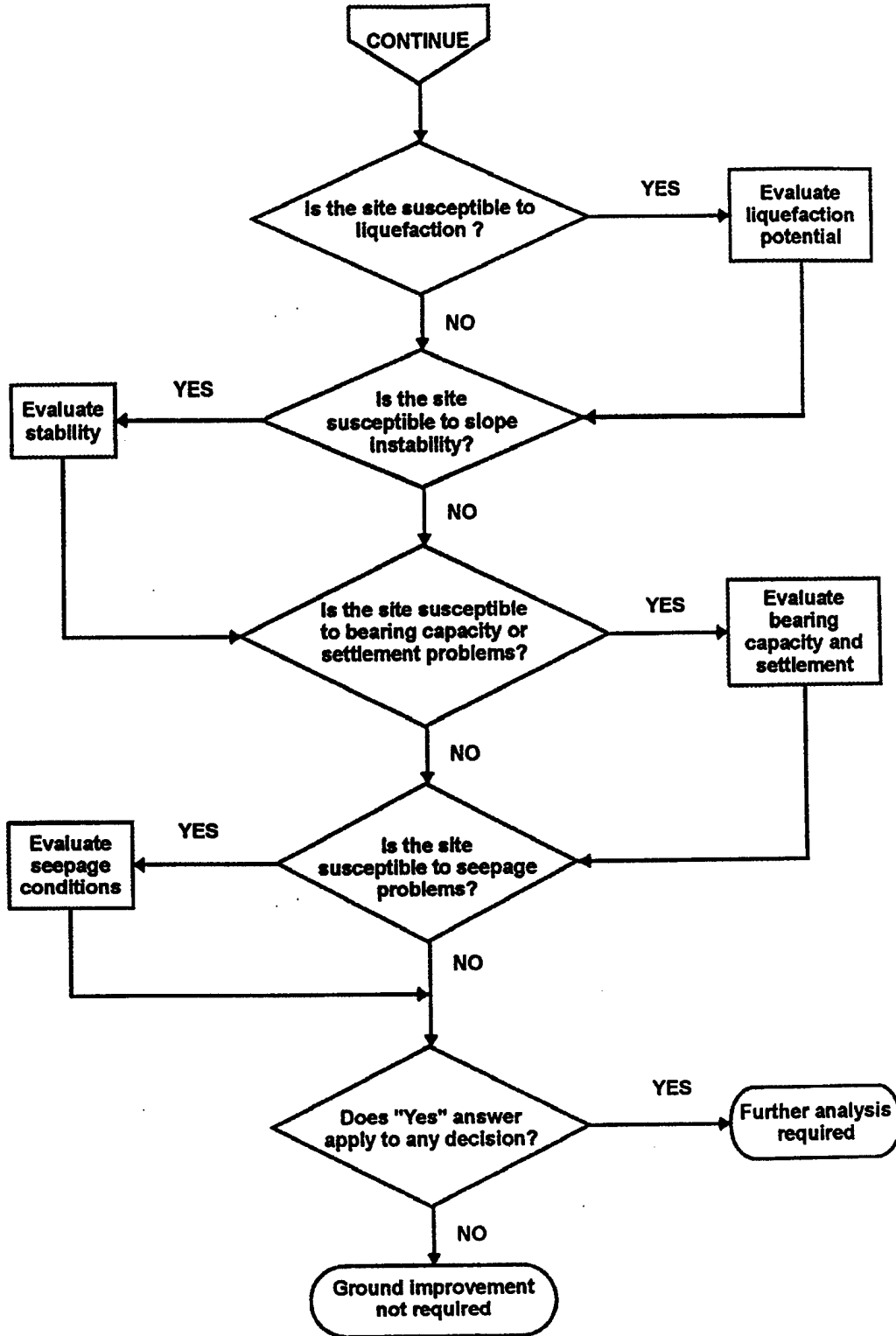
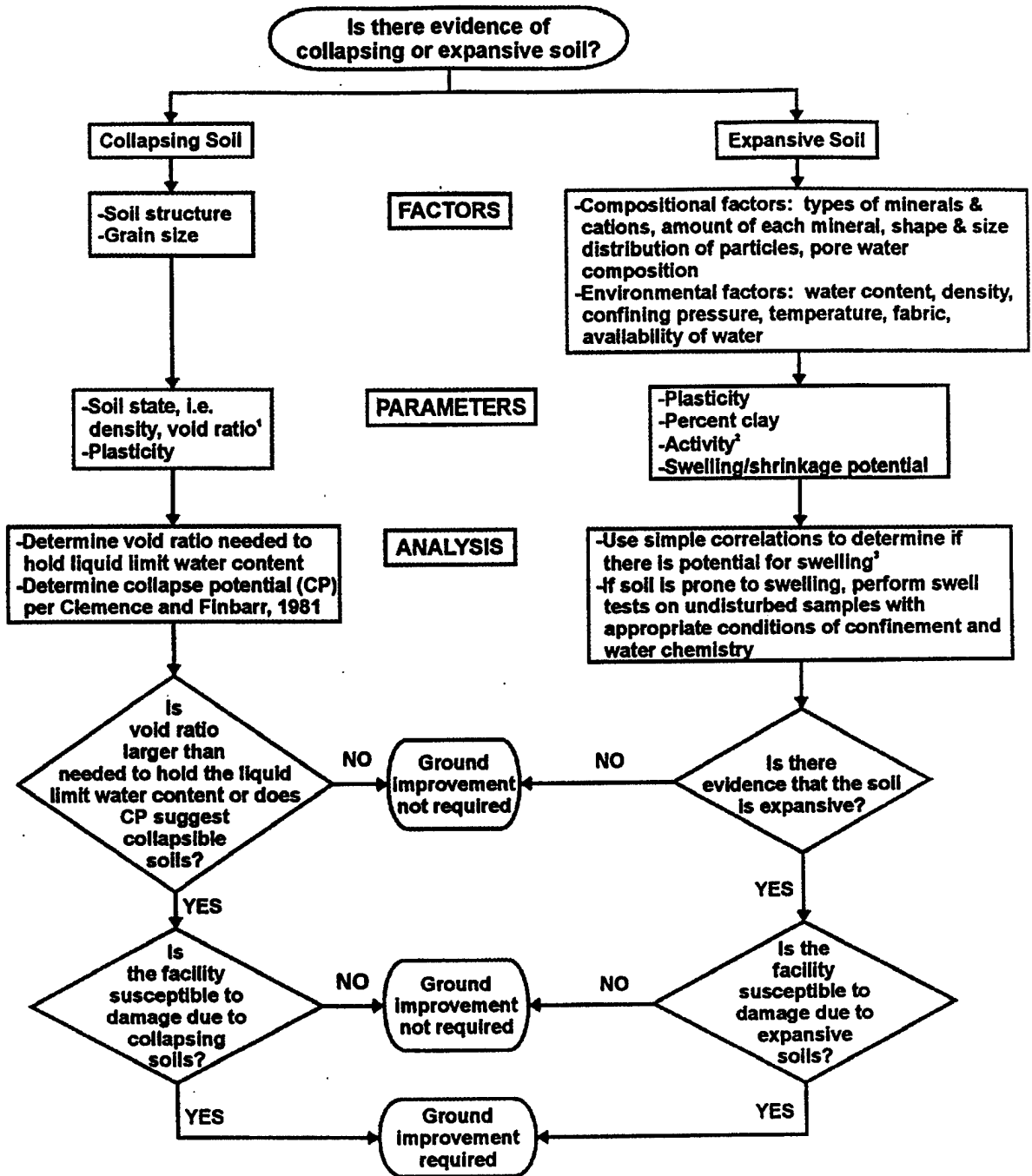

FIGURE 2 continued



Notes:

1. See Figure 17 for assessment methods for soil state parameters.
2. Activity, $A = \frac{\text{Plasticity Index}}{\text{Percent clay}}$
Percent clay, C = Percent by weight of particles finer than 2 microns
3. Two correlations are discussed in Mitchell (1993), pp. 186-187

FIGURE 3 Difficult Soils Evaluation - Collapsing or Expansive Soils

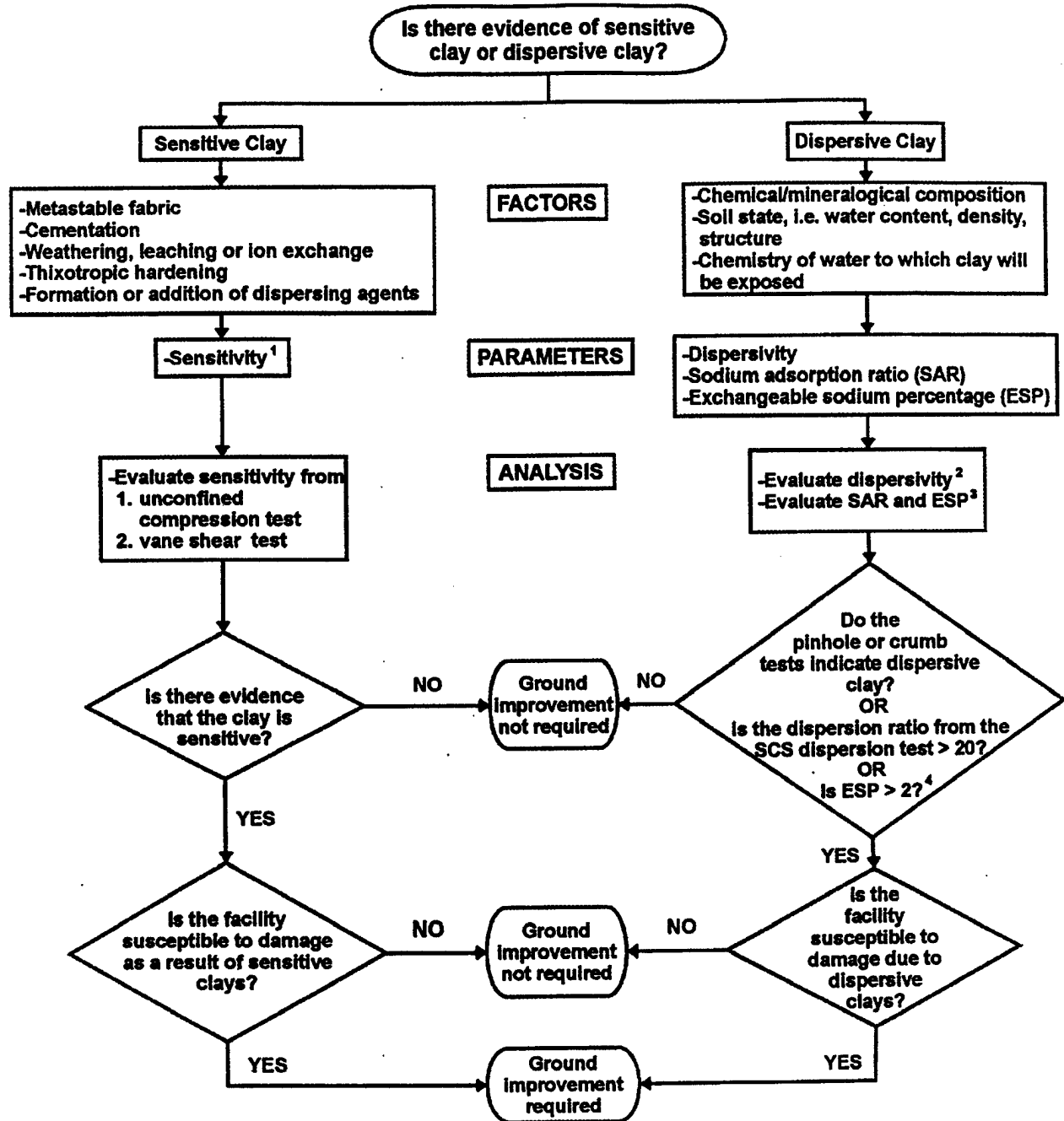

Notes:

1. Sensitivity, S_1 , is the ratio of peak undisturbed strength to remolded strength at the same water content.
2. Evaluate dispersivity from pinhole test (ASTM D 4647), SCS dispersion test (ASTM D 4221) or crumb test (Sherard et al., 1976). Pinhole test is considered most reliable (Mitchell, 1993).
3. Evaluate SAR by chemical analysis of pore water. Calculate ESP from SAR (Mitchell, 1993).
4. "No" response appropriate if it applies to all results from dispersivity tests. Otherwise, "Yes" response appropriate.

FIGURE 4 Difficult Soils Evaluation - Sensitive or Dispersive Clay

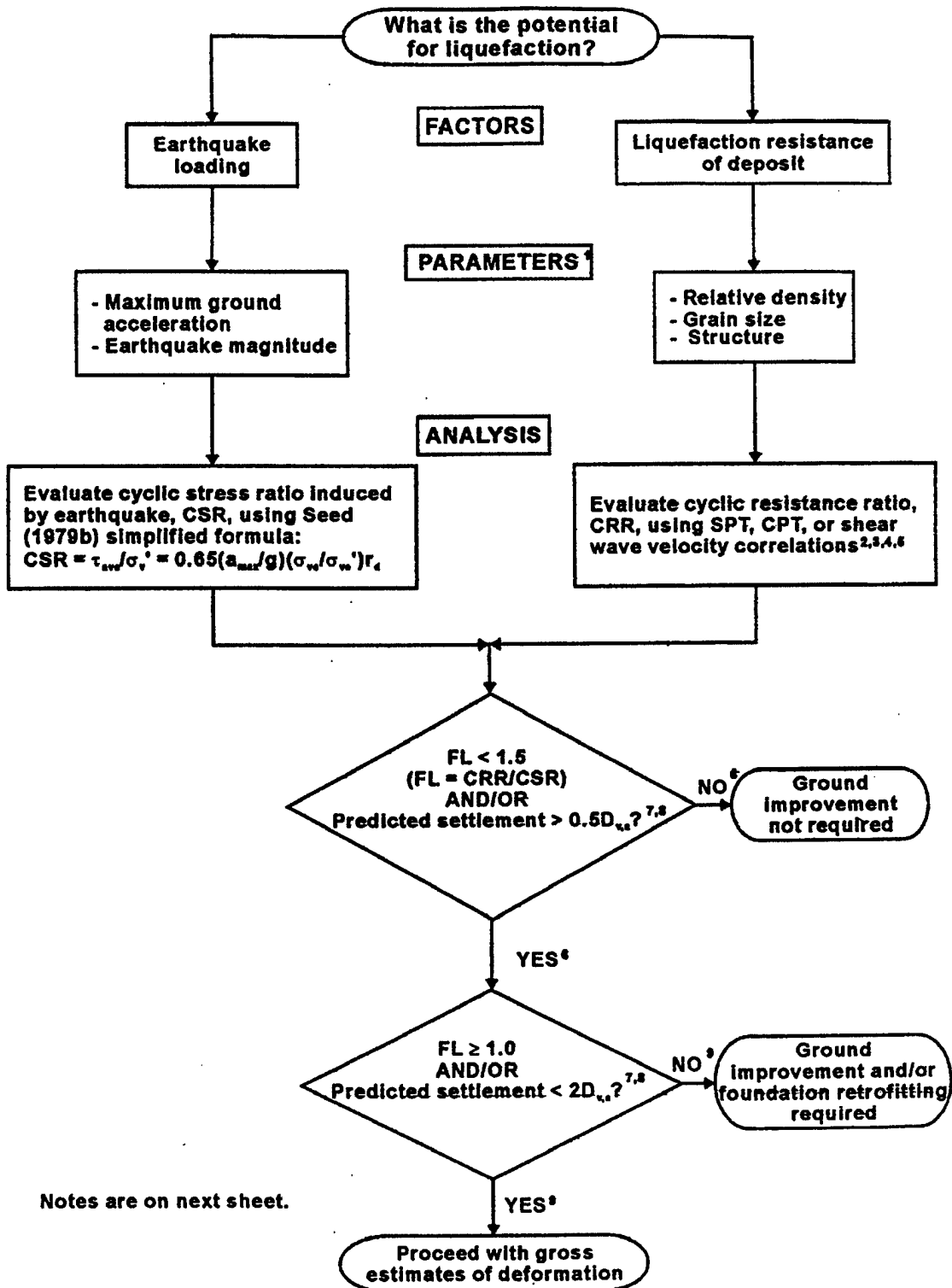

FIGURE 5 Evaluation of Liquefaction Potential

Notes:

1. Assessment methods for parameters are given in Figure 18.
2. Evaluation of liquefaction resistance by CPT is generally preferred because penetration data is nearly continuous with depth and more reliable. Obtain SPT and CPT correlations with CRR from NCEER (1997) for clean sands.

Correct SPT and CPT correlations with CRR per NCEER (1997) for: fines content, influence of thin soil layers, earthquake magnitudes different than $M = 7.5$, vertical effective confining stress using K_σ , and static horizontal shear stress using K_α .
3. Shear wave velocity can be used as a supplemental method to SPT or CPT for evaluating cyclic resistance ratio (CRR) per NCEER (1997).
4. Liquefaction resistance of gravelly soils should be evaluated per NCEER (1997). The Becker Penetration Test (BPT) may be required for soils with high content of gravel and cobbles.
5. If possible, site specific liquefaction potential curves should be developed and used when no liquefaction resistance correlations are available for the soils encountered. These curves can be developed in the laboratory for soils which can be sampled (using specialized methods if necessary and possible) using cyclic CU triaxial or cyclic simple shear tests.
6. "No" response appropriate if it applies to both factor of safety and settlement criteria. "Yes" response appropriate if it applies to either or both criteria.
7. Deposits of cohesionless soils above groundwater (particularly those which are loose) are also susceptible to densification settlement during earthquake shaking. Estimated settlements of these deposits should be calculated using available methods (e.g. Tokimatsu and Seed, 1987) and included in settlement estimates for comparison to acceptable settlement limits.
8. $D_{v,a}$ is the allowable vertical movement (allowable settlement) of the foundation determined by the structural engineer.
9. "Yes" response appropriate if it applies to both factor of safety and settlement criteria. "No" response appropriate if it applies to either or both criteria.

FIGURE 5 (continued)

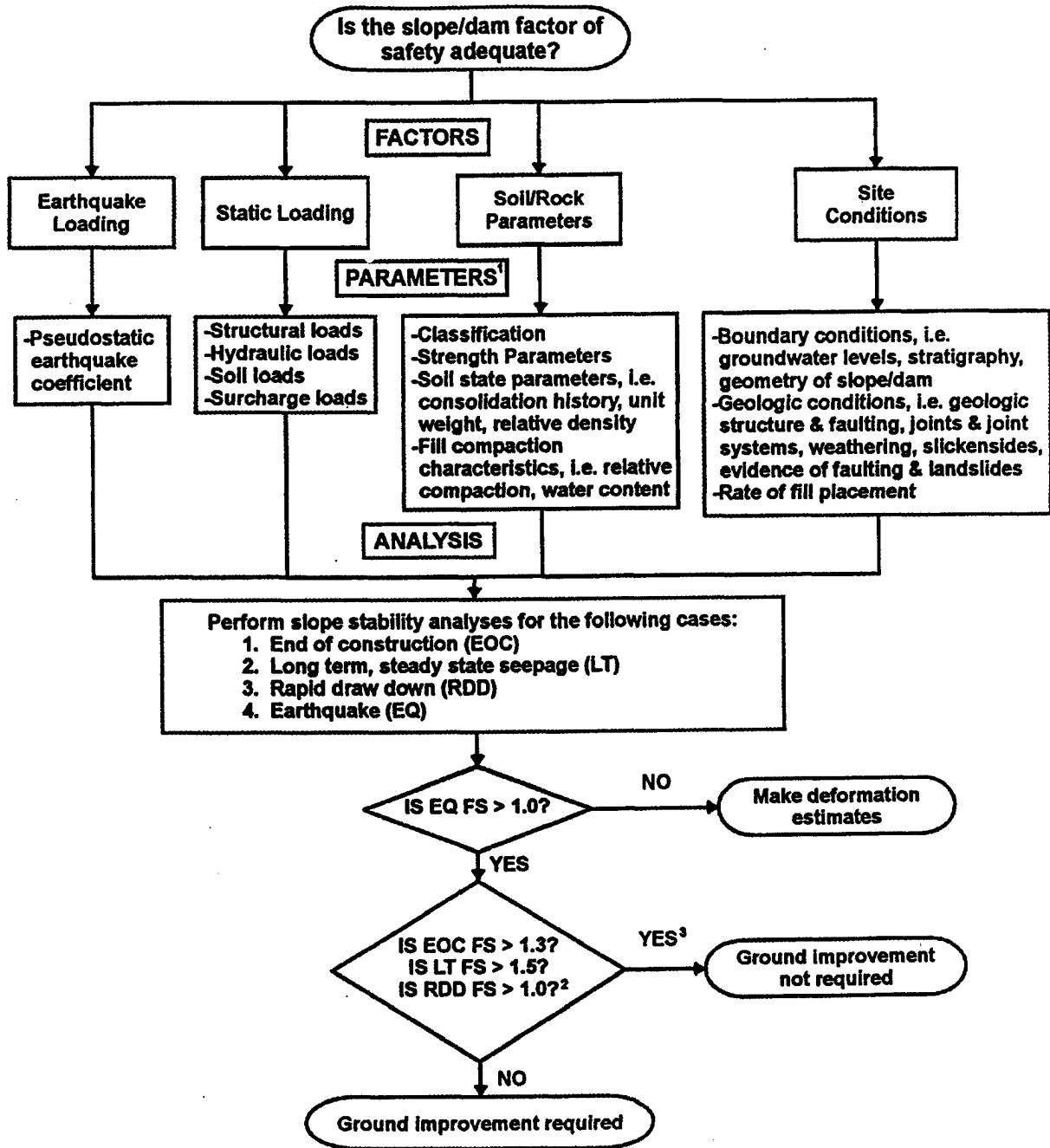

Notes:

1. Assessment methods for parameters are given in Figures 19 and 20.
2. Based on EM-1110-2-1902 (Stability of Earth and Rockfill Dams). Criteria may be different for different projects.
3. "Yes" response appropriate if it applies to all criteria. "No" response appropriate if it applies to any criterion.

FIGURE 6 Slope Stability Evaluation

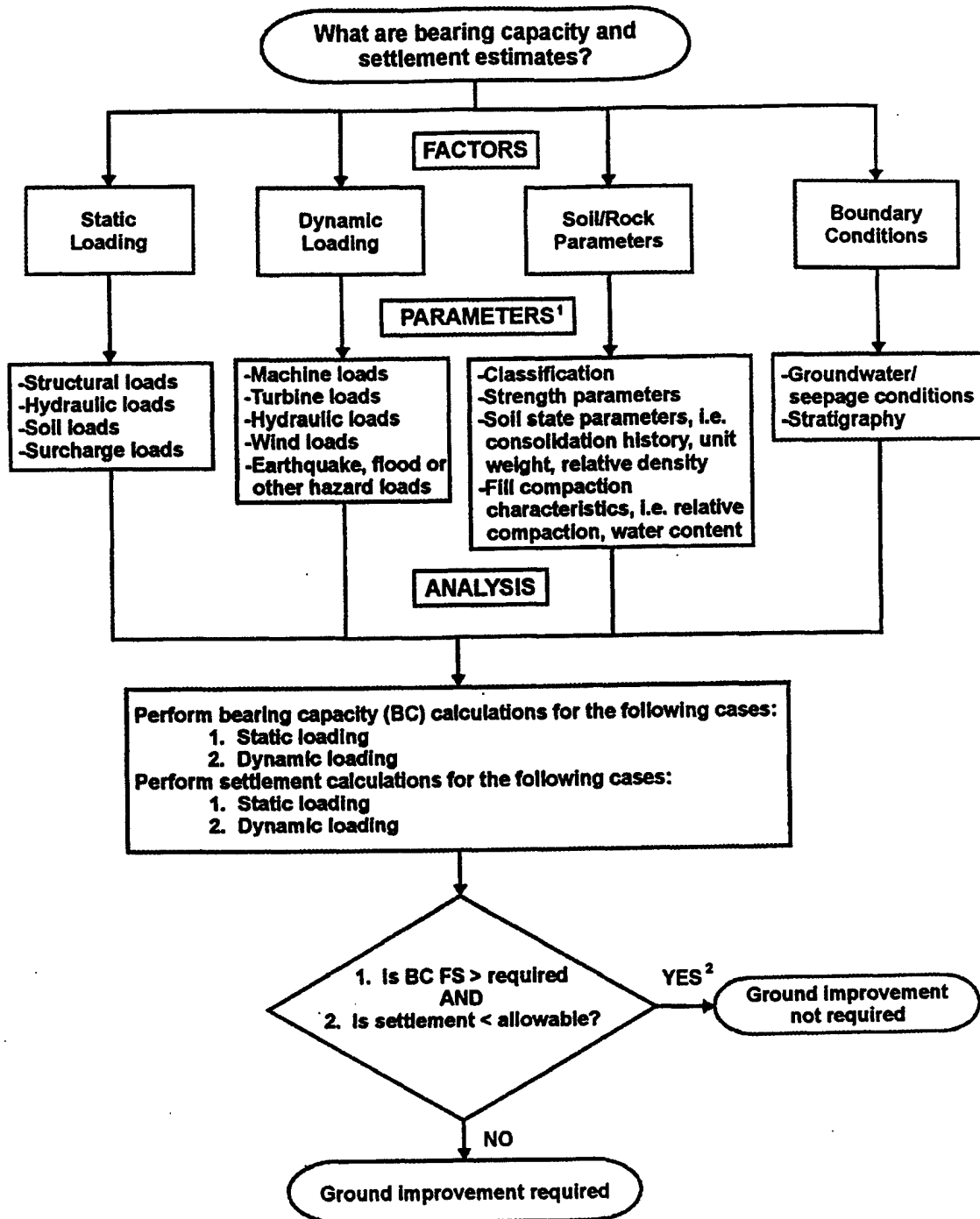

Notes:

1. Assessment methods for parameters are given in Figures 19 and 20.
2. If "Yes" answer applies to both decisions, ground improvement is not required. If "No" answer applies to either decision, ground improvement is required.

FIGURE 7 Bearing Capacity and Settlement Evaluation

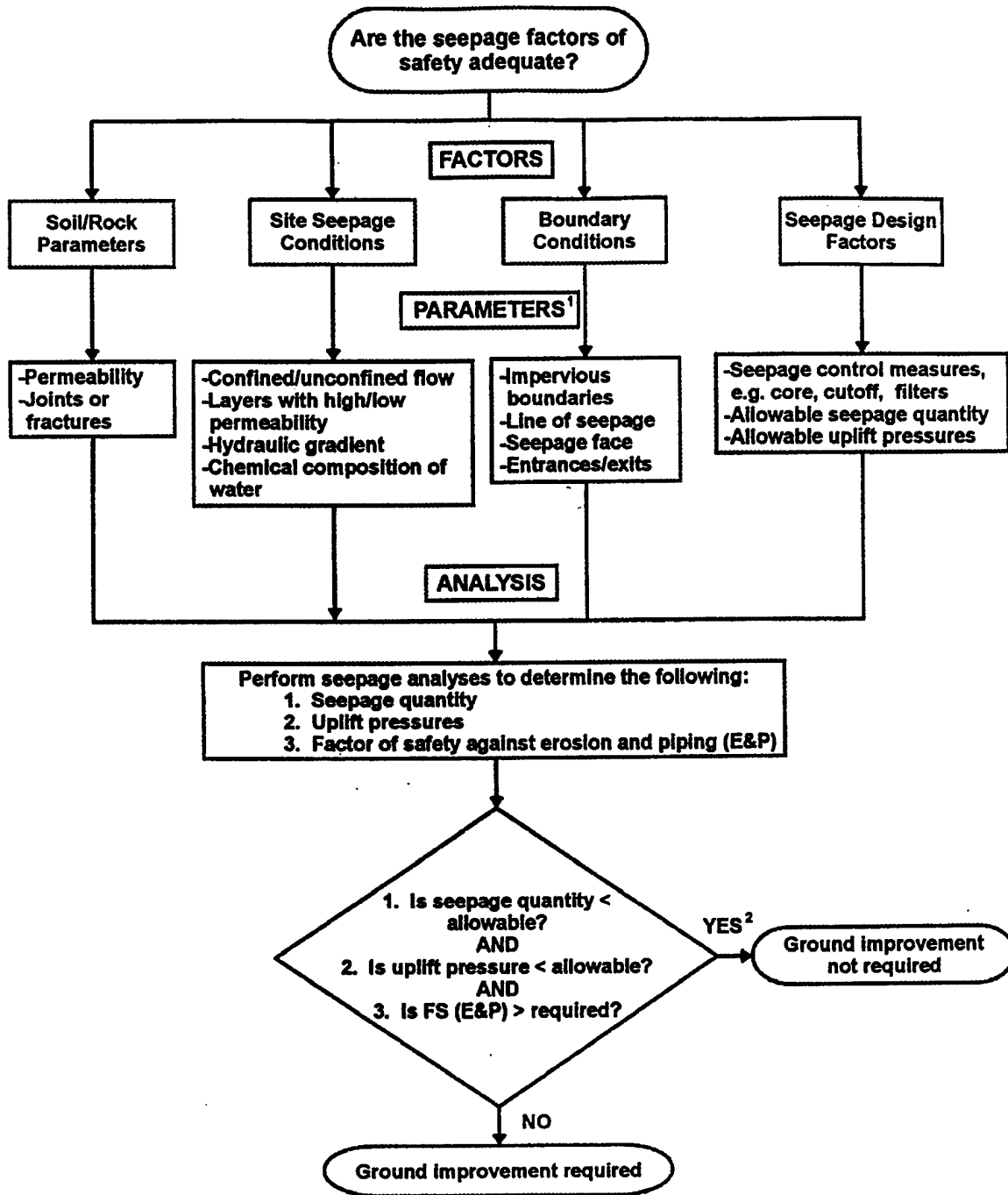

Notes:

1. Assessment methods for parameters are given in Figure 21.
2. If "Yes" answer applies to all decisions, ground improvement is not required. If "No" answer applies to any decision, ground improvement or other mitigation strategy is required.

FIGURE 8 Seepage Evaluation

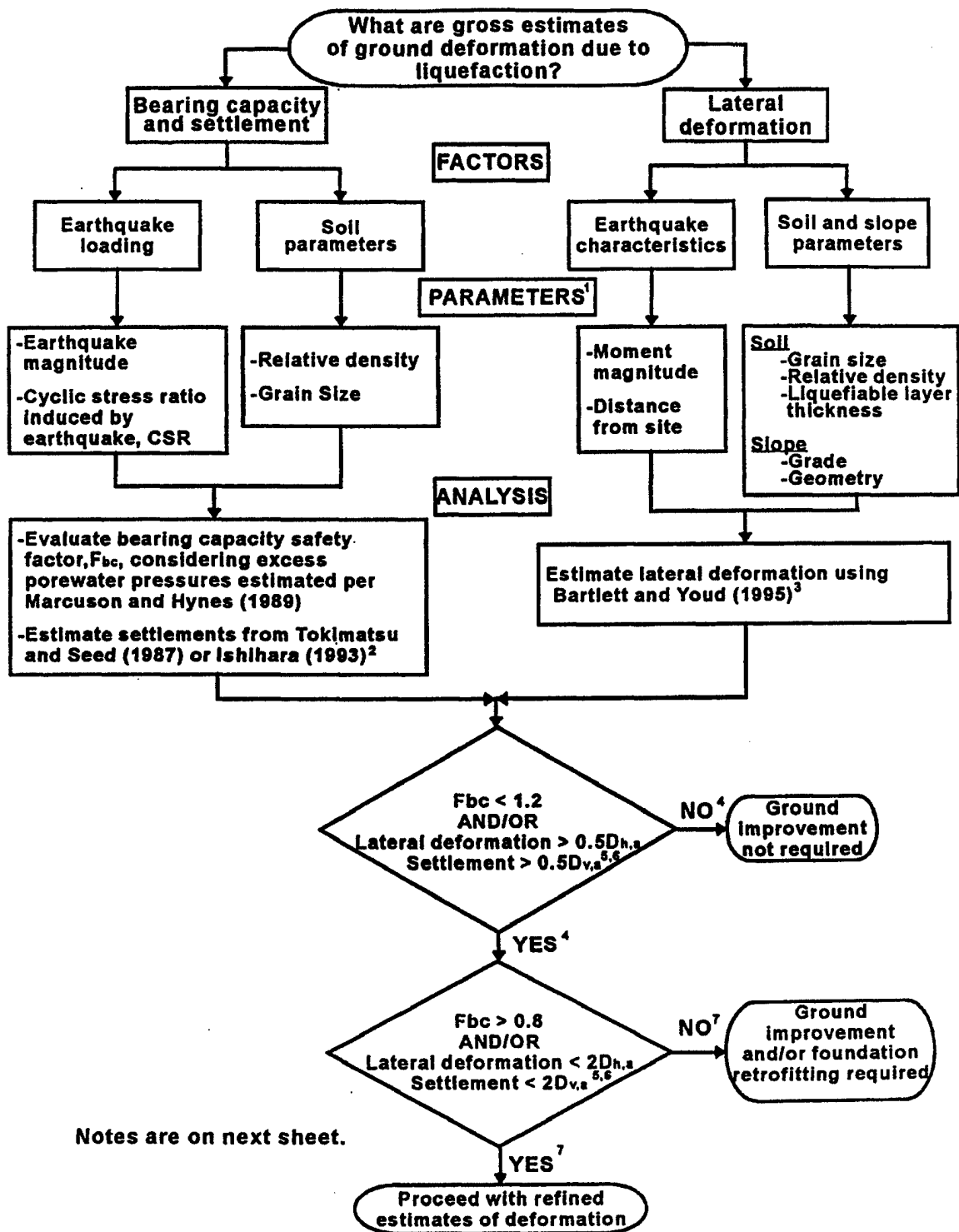

FIGURE 9 Liquefaction Evaluation - Gross Deformation Estimates

Notes:

- 1. Assessment methods for parameters are given in Figure 22.**
- 2. Tokimatsu and Seed (1987) and Ishihara (1993) procedures were developed for "clean" sands. For silty sands an equivalent "clean" sand $(N_1)_{60}$ value can be computed using the method described by NCEER (1997) for use with charts.**

For other soil types susceptible to liquefaction, settlements can be estimated using results from cyclic CU triaxial tests on "undisturbed" samples subjected to cyclic stress levels causing liquefaction. Samples are reconsolidated after liquefaction to obtain volumetric strain data. Volumetric strain is then correlated to the factor of safety against liquefaction, F_L , and the relative density/penetration resistance of the soil.

- 3. For sites not satisfying seismic and site condition limits specified by Bartlett and Youd (1995), lateral deformations can be estimated using Newmark's (1965) method. Reduced shear strengths should be used along the failure surface in liquefied soil.**
- 4. "No" response appropriate if it applies to both factor of safety and settlement/lateral deformation criteria. "Yes" response appropriate if it applies to either or both criteria.**
- 5. Estimated settlements should include densification settlements of cohesionless soils above groundwater (per Tokimatsu and Seed, 1987) and settlements due to deformations from lateral spreading and reduction in bearing capacity, as well as those from dissipation of liquefaction-induced excess porewater pressures of saturated soils.**
- 6. $D_{v,a}$ and $D_{h,a}$ are the allowable vertical and horizontal movements, respectively, of the foundation as determined by the structural engineer.**
- 7. "Yes" response appropriate if it applies to both factor of safety and settlement/lateral deformation criteria. "No" response appropriate if it applies to either or both criteria.**

FIGURE 9 (continued)

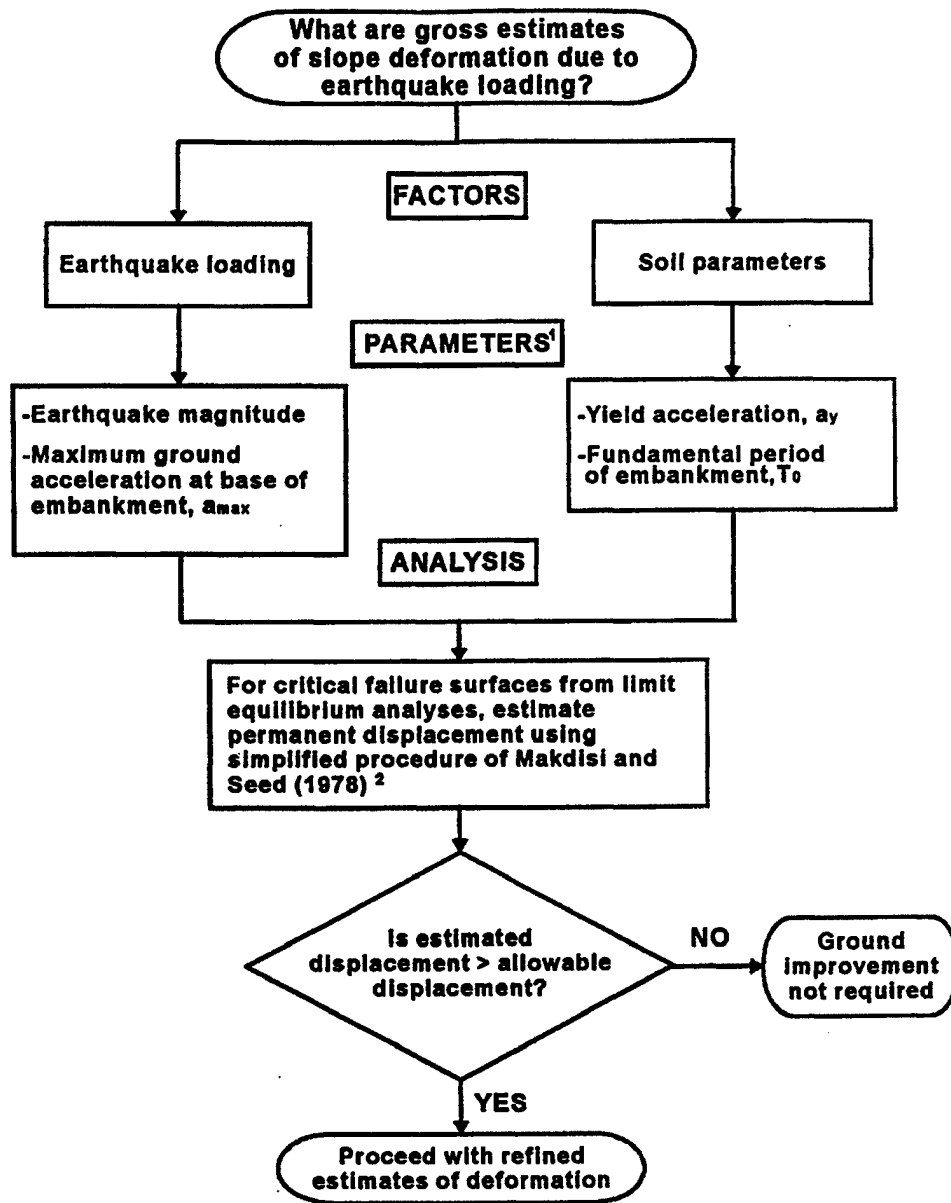

Notes:

1. Assessment methods for earthquake parameters are given in Figure 15. Assessment methods for soil parameters are given in Figure 23.
2. This procedure was developed using the dynamic response characteristics of dams and embankments. If used for other types of slopes, the results must be used with caution.

FIGURE 10 Slope Stability Evaluation - Gross Deformation Estimates

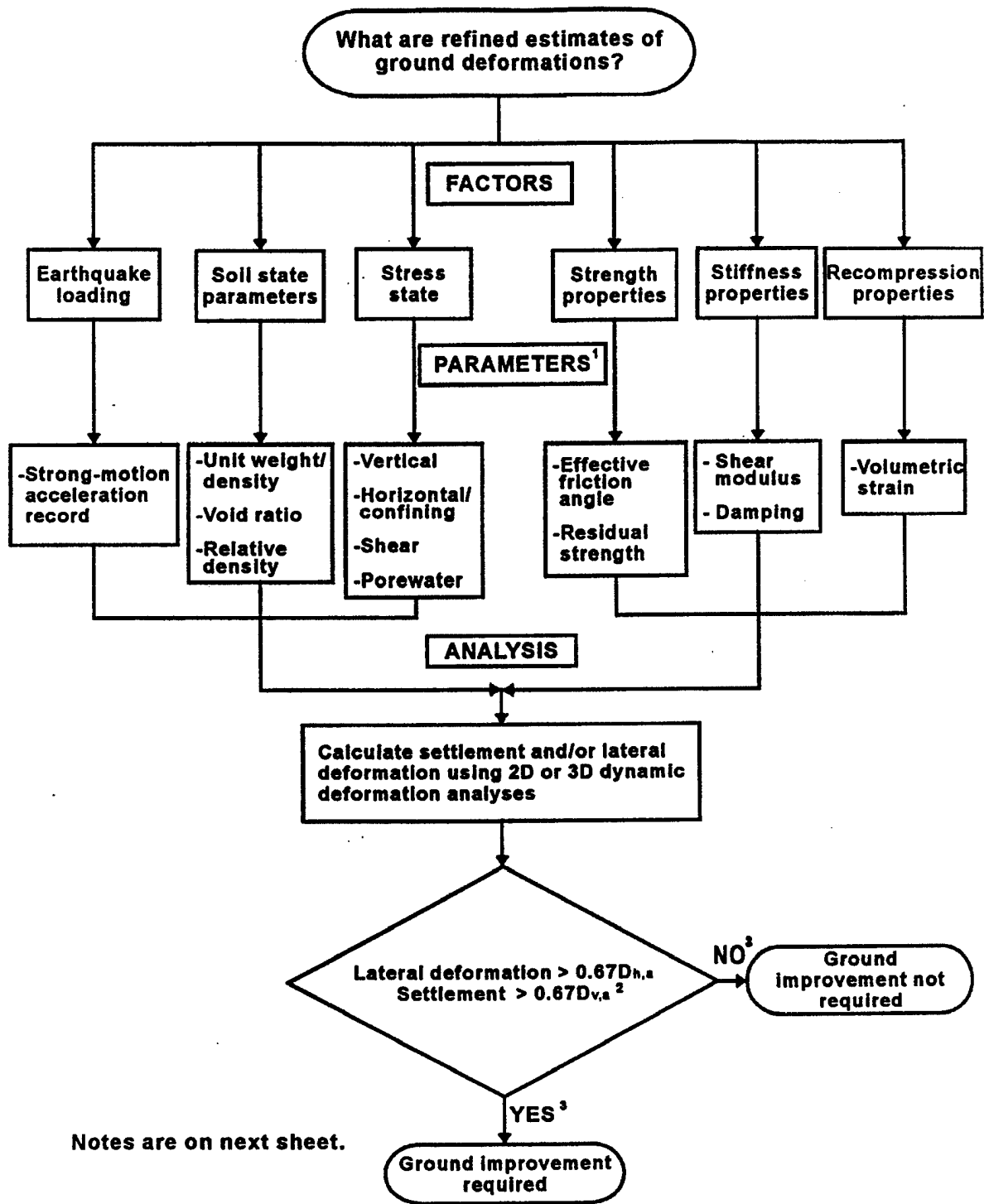
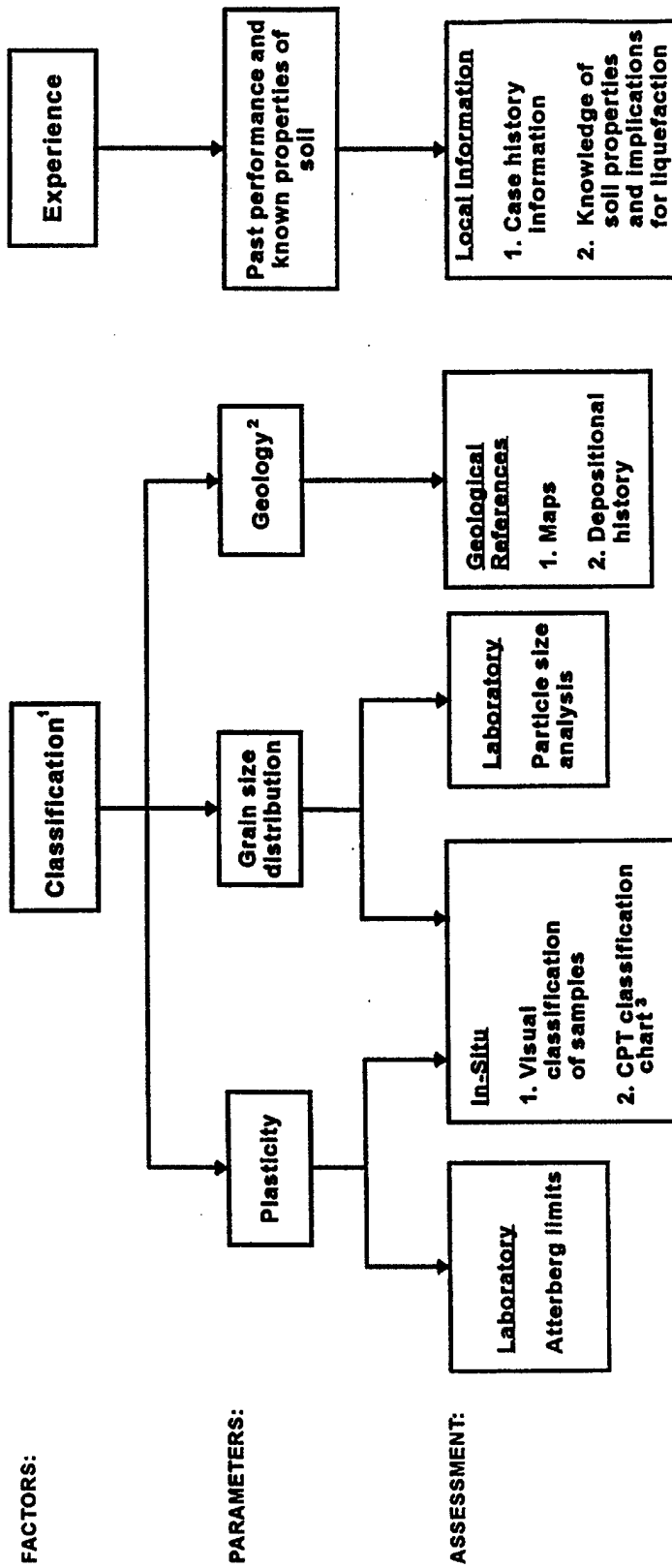

FIGURE 11 Refined Deformation Estimates for Liquefaction and Slope Stability Evaluations

Notes:

- 1. Assessment methods for parameters are given in Figures 17, 19 and 24 through 26.**
- 2. Estimated settlements should include densification settlements of cohesionless soils above groundwater (e.g. Tokimatsu and Seed, 1987) and settlement due to deformations from lateral spreading and reduction in bearing capacity, as well as those from dissipation of liquefaction-induced excess porewater pressures of saturated soils.**
- 3. "No" response appropriate if it applies to both lateral deformation and settlement. "Yes" response appropriate if it applies to either lateral deformation or settlement, or both.**

FIGURE 11 (continued)



Notes:

1. Refer to EM 1110-1-1804 (Geotechnical Investigations) and EM 1110-2-1906 (Soil Sampling) for COE procedures.
2. Geologic information provides some general insights regarding soil composition, fabric, and structure.
3. Use chart in accordance with NCEER (1997). CPT should only be used for classification after verification of its suitability by soil sampling adjacent to some CPT soundings.

FIGURE 12 Assessment Methods for Soil Classification and Experience Parameters for Preliminary Evaluation of Site Conditions and Design/Performance Requirements

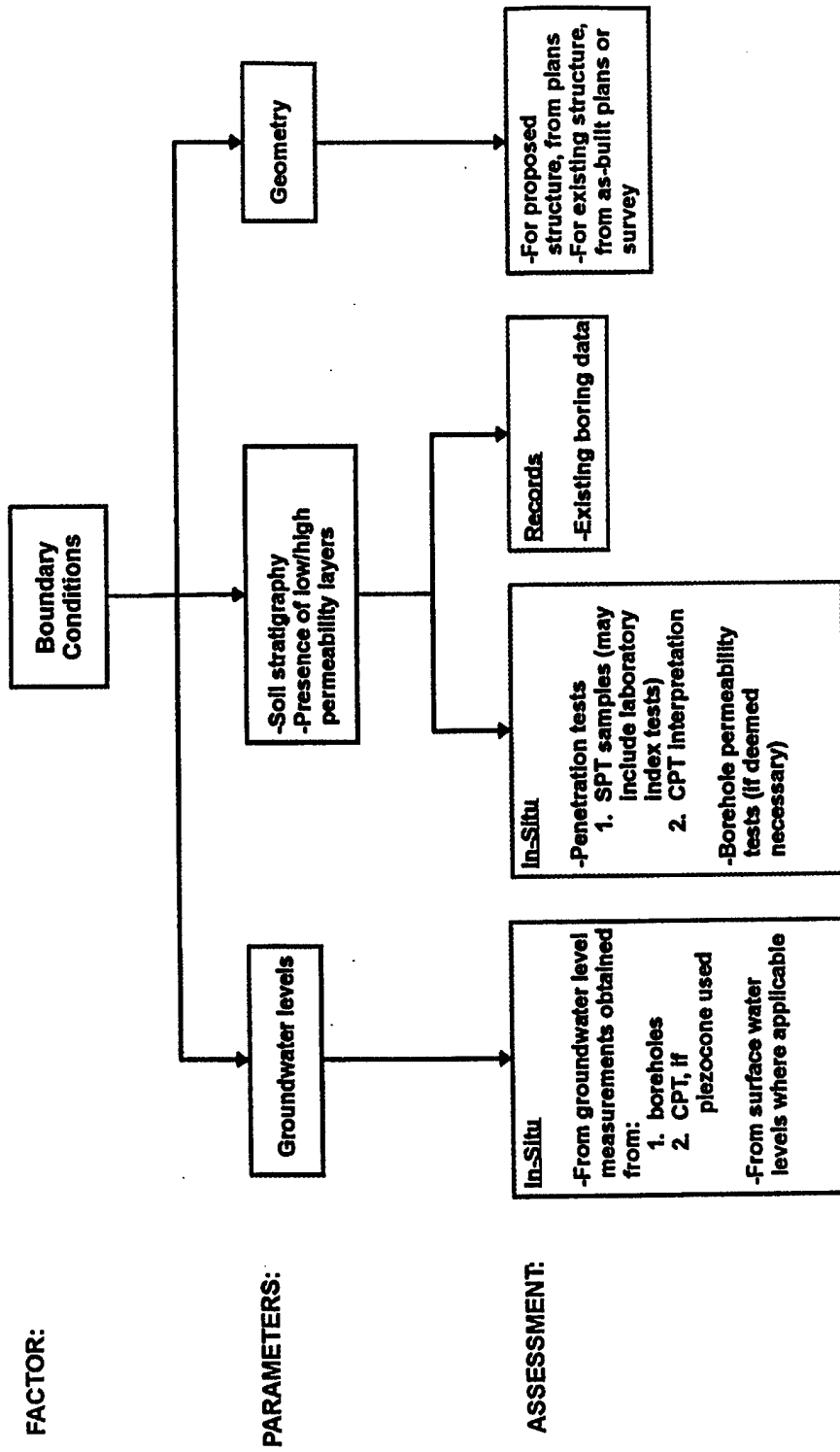

FIGURE 13 Assessment Methods for Boundary Condition Parameters for Preliminary Evaluation of Site Conditions and Design/Performance Requirements

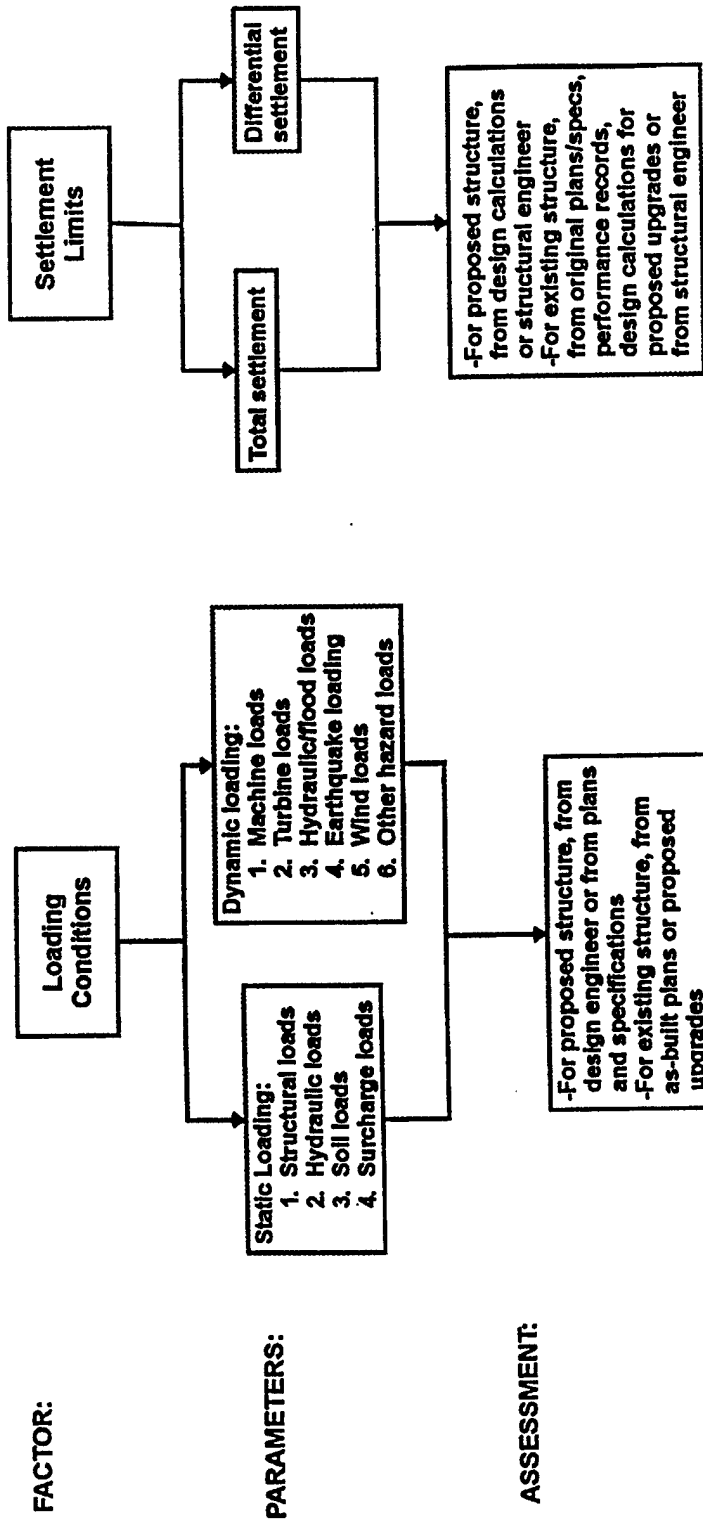
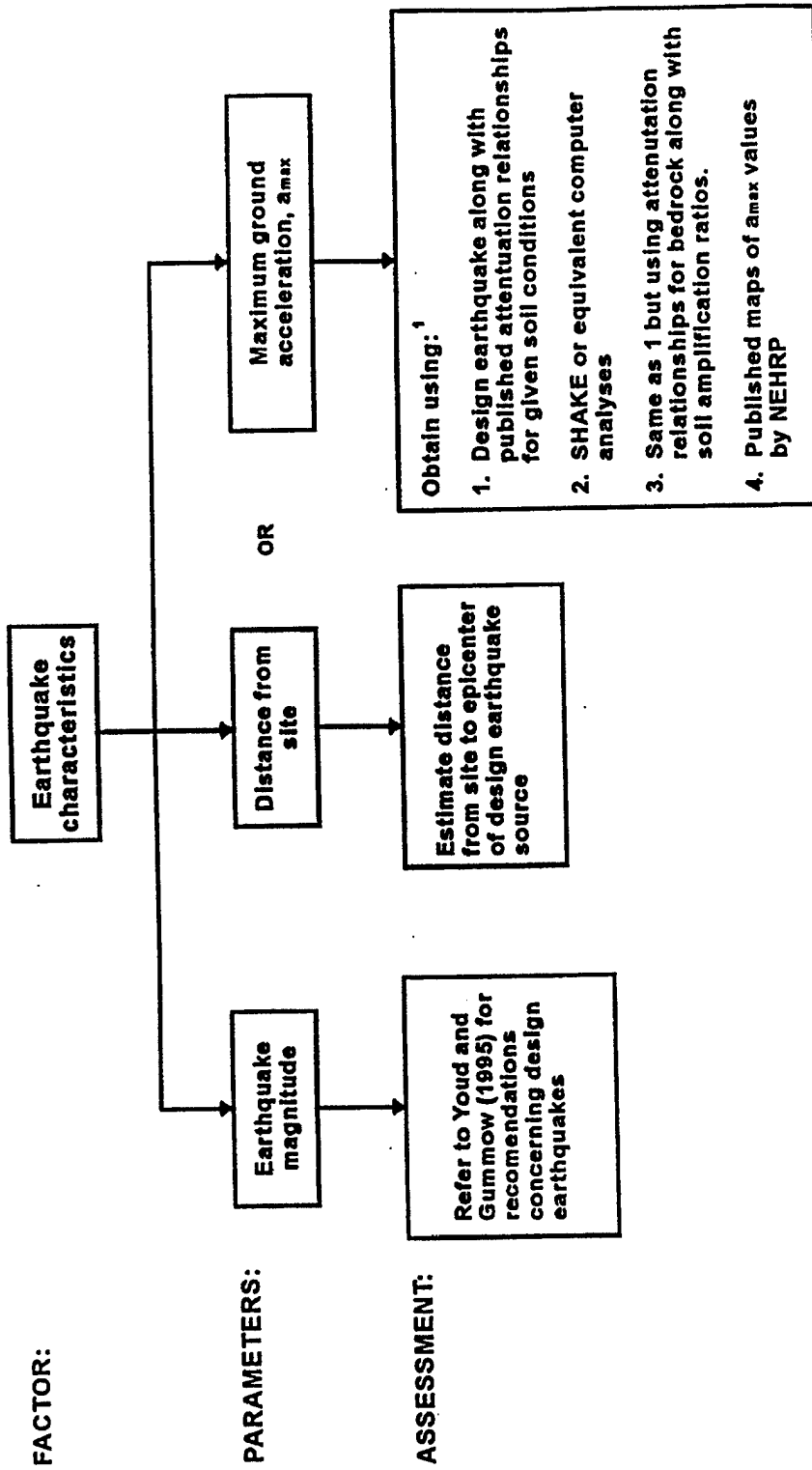

FIGURE 14 Assessment Methods for Loading Conditions and Settlement Parameters for Preliminary Evaluation of Site Conditions and Design/Performance Requirements



Notes:

1. From NCEER (1997): Option 1 is the preferred method when such relationships are available for the given soil conditions. Option 2 should be used if attenuation relationships for given soil conditions (Option 1) are not available. Option 3 is least desirable because of magnitude and potential frequency dependency of amplification. Option 4 is not discussed.

FIGURE 15 Assessment Methods for Earthquake Characteristic Parameters for Preliminary Evaluation of Site Conditions and Design/Performance Requirements

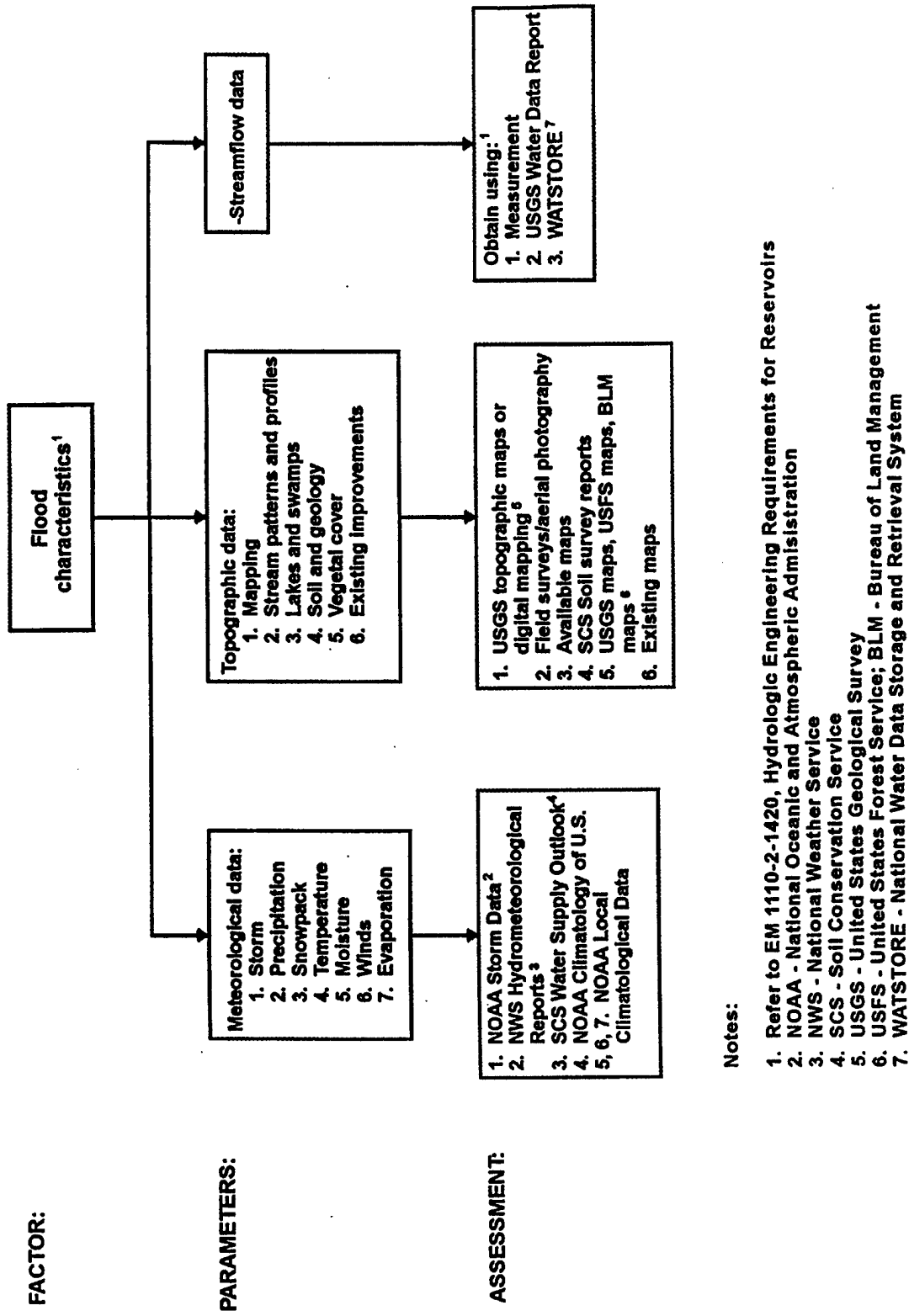
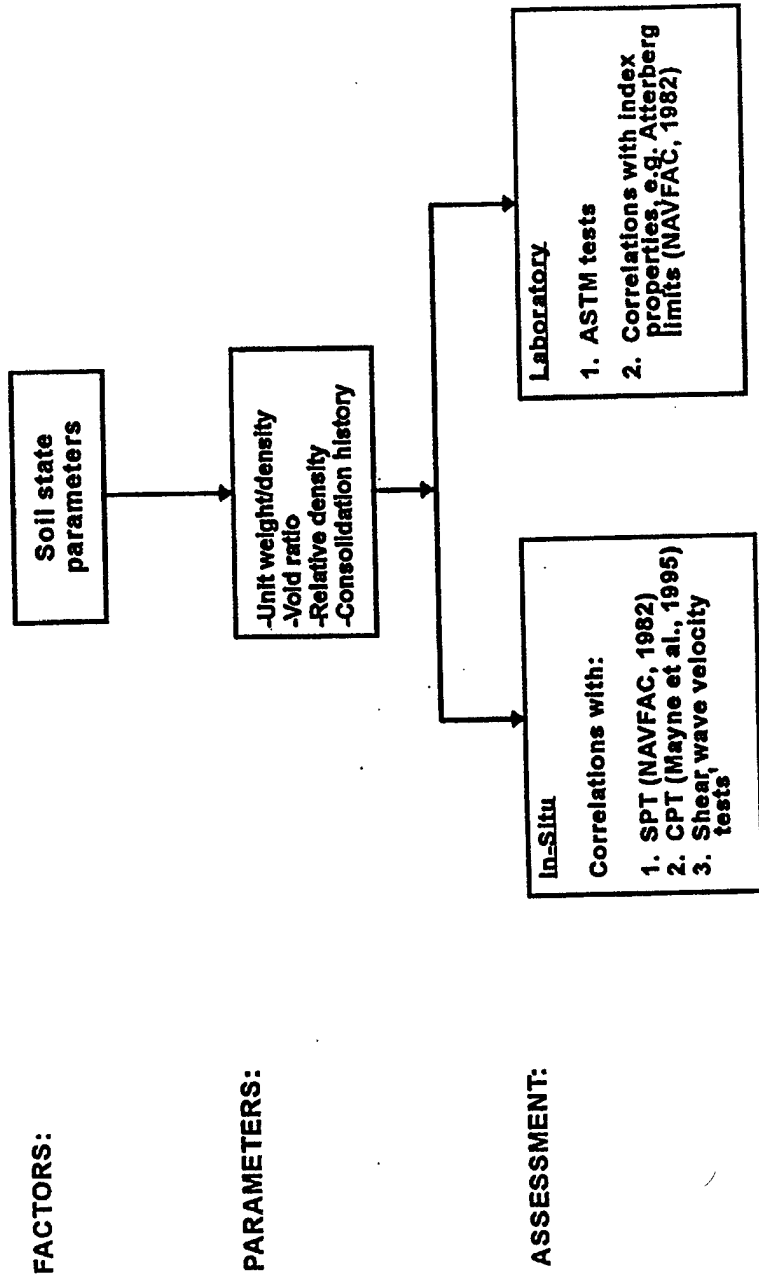

FIGURE 16 Assessment Methods for Flood Parameters for Preliminary Evaluation of Site Conditions and Design/Performance Requirements



Notes:

1. Correlation of shear wave velocity with void ratio, relative density or unit weight is not well established. Therefore, CPT or SPT tests should be used in conjunction with shear wave velocity tests to help evaluate these parameters.

FIGURE 17 Assessment Methods for Soil State Parameters for Difficult Soils, Slope Stability, and Seepage Evaluations

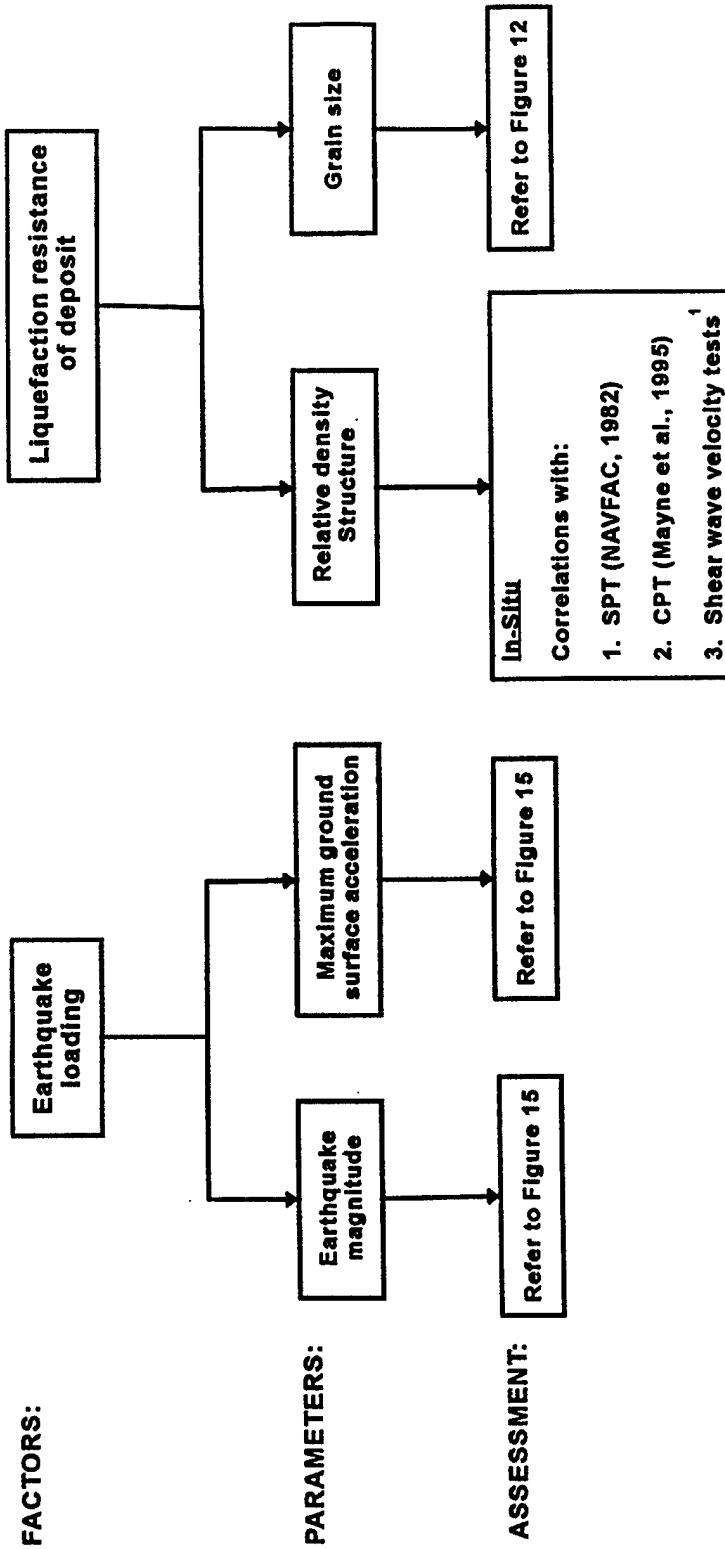

Notes:

- Correlation of shear wave velocity with relative density is not well established. Therefore, CPT or SPT tests should be used in conjunction with shear wave velocity tests to help evaluate this parameter.

FIGURE 18 Assessment Methods for Earthquake Loading and Liquefaction Resistance Parameters for Evaluation of Liquefaction Potential

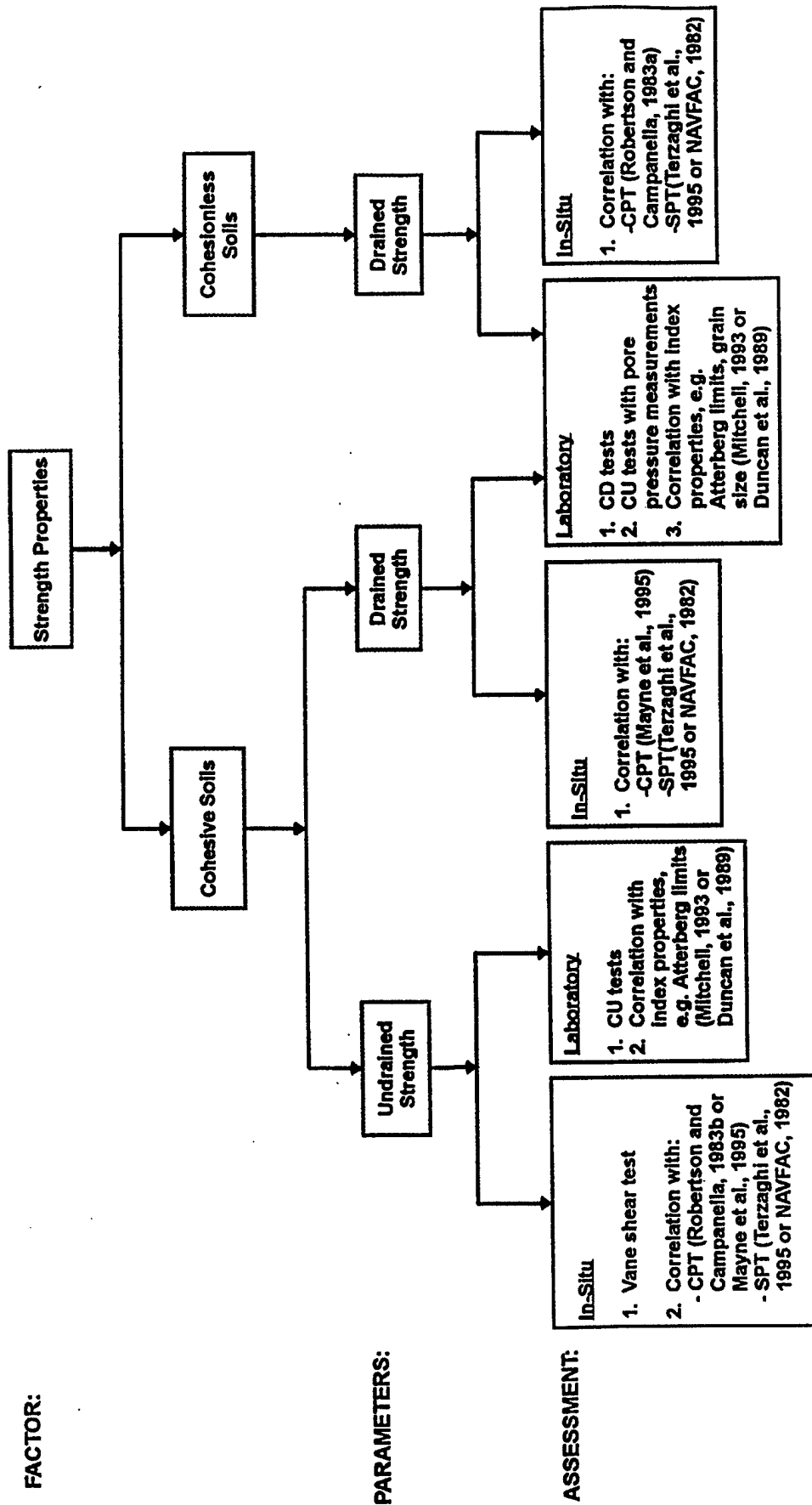

FIGURE 19 Assessment Methods for Strength Properties for Slope Stability and Bearing Capacity Evaluations

Factors	Parameters	Assessment
Earthquake loading	Pseudostatic earthquake coefficient	For most cases, $k_h = 0.5a_{max}/g$ Refer to text for additional guidance
Static Loading	Structural loads Hydraulic loads Soil loads Surcharge loads	Refer to Figure 14
Soil/rock parameters	Classification Soil state parameters Strength parameters Fill compaction characteristics	Refer to Figure 12 Refer to Figure 17 Refer to Figure 19 From laboratory tests
Site conditions	Boundary conditions Geologic conditions Rate of fill placement	Refer to Figure 13 From geotechnical investigation report From construction schedule

FIGURE 20 Parameter Assessment Methods for Slope Stability, Bearing Capacity and Settlement Evaluations

<u>Factors</u>	<u>Parameters</u>	<u>Assessment</u>
Soil/rock parameters	Permeability	From laboratory or field tests
	Joints or fractures	From geotechnical investigation report
Site boundary conditions	Confined/unconfined flow	Refer to Figure 13
	Layers with high/low permeability	Refer to Figure 13
	Hydraulic gradient	From construction plans
	Chemical composition of water	From laboratory tests
Seepage boundary conditions	Impervious boundaries	Refer to Figure 13
	Line of seepage	From flow net or FE* analysis
	Seepage face	From flow net or FE analysis
	Entrances/exits	From flow net or FE analysis
Seepage design factors	Seepage control measures	From construction plans
	Allowable seepage quantity	From performance requirements
	Allowable uplift pressures	From design requirements

* Finite element

FIGURE 21 Parameter Assessment Methods for Seepage Evaluation

Factors	Parameters	Assessment
Earthquake loading	Earthquake magnitude Cyclic Stress Ratio (CSR)	Refer to Figure 15 Refer to Figure 15 for a_{max} ; $CSR = 0.65(a_{max}/g) * (\sigma_{vo}/\sigma'_{vo})^{rd}$
Soil parameters	Relative density Grain Size	Refer to Figure 18 Refer to Figure 12
Earthquake characteristics	Moment magnitude Distance from site	Refer to Figure 15 Refer to Figure 15
Soil and slope parameters	Soil Grain size Relative density Liquefiable layer thickness	Refer to Figure 12 Refer to Figure 18 Soil borings or CPT soundings
	Slope Grade and geometry	1. Construction plans 2. Field reconnaissance

FIGURE 22 Parameter Assessment Methods for Liquefaction Evaluation - Gross Deformation Estimates

FACTORS:

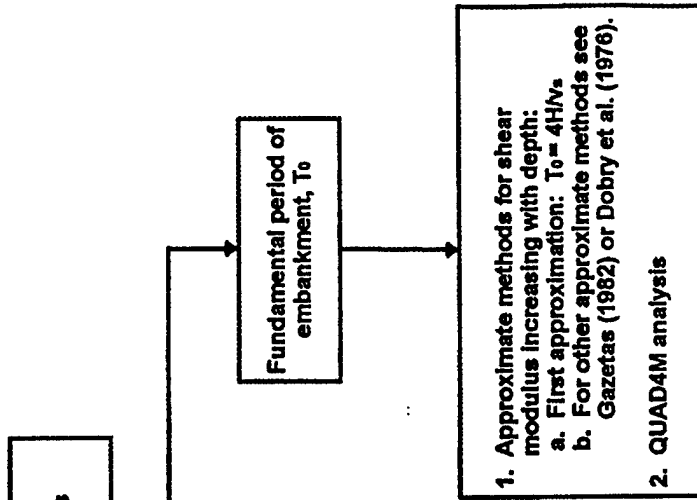

PARAMETERS:

Yield acceleration, a_y

Fundamental period of embankment, T_0

ASSESSMENT:

1. The yield acceleration is defined as the average acceleration producing a horizontal inertial force that results in a factor of safety of 1 for the particular failure plane.

2. For soils that do not develop large shear strains, calculate yield acceleration using the limit equilibrium methods and assuming the dynamic shear strength of the material is equal to 80% of the static shear strength (Makdisi and Seed, 1978).

1. Approximate methods for shear modulus increasing with depth:
a. First approximation: $T_0 = 4H/v_s$
b. For other approximate methods see Gazetas (1982) or Dobry et al. (1976).

2. QUAD4M analysis

FIGURE 23 Assessment Methods for Soil Parameters for Slope Stability Evaluation - Gross Deformation Estimates

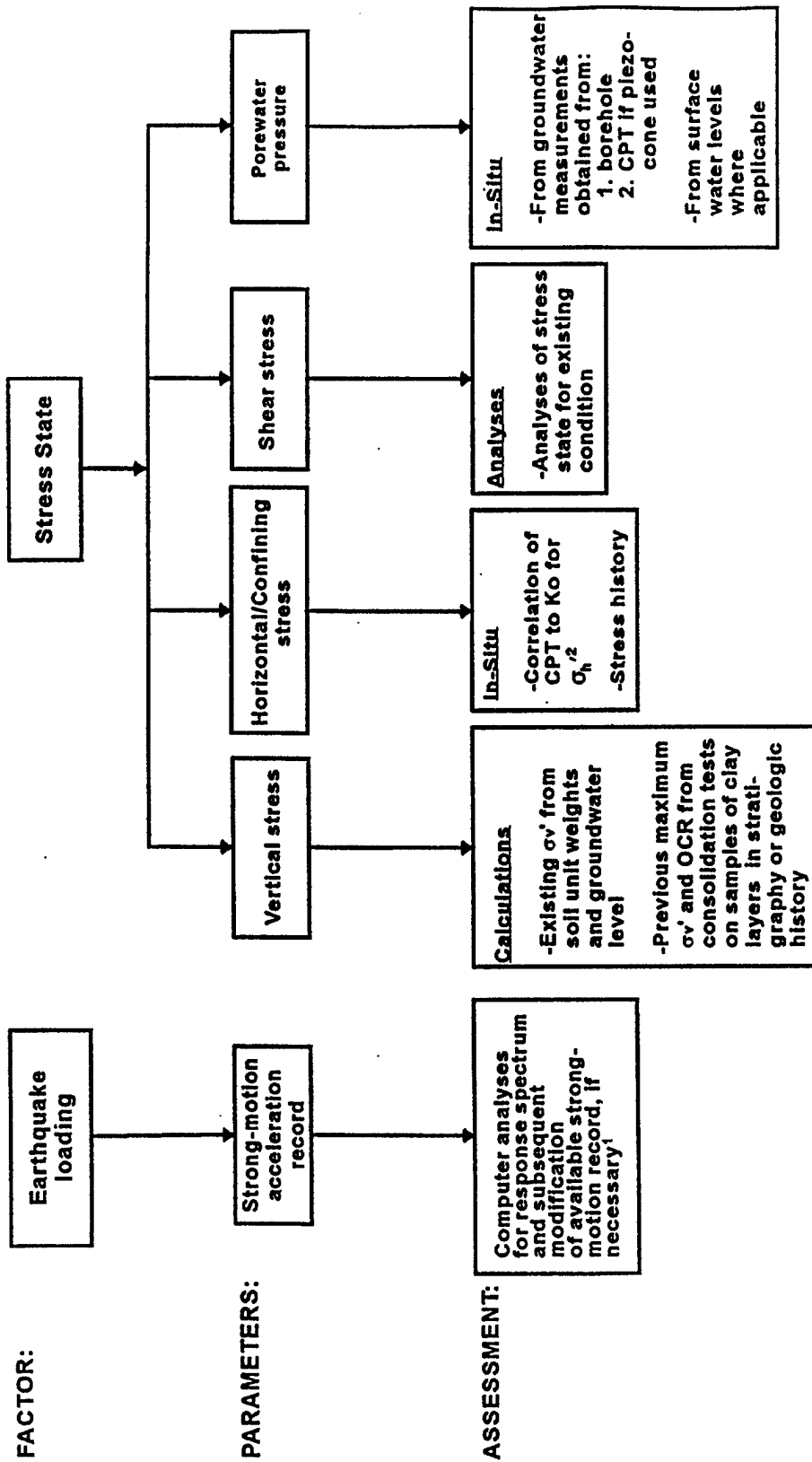

Notes:

1. Computer analyses to determine response spectrum from strong-motion bedrock record can be performed using SHAKE, QUAD4M or equivalent analysis. Modify strong-motion record as necessary to obtain desired design response spectrum.
2. Reference Kuhlhawy and Mayne (1990).

FIGURE 24 Assessment Methods for Earthquake Loading and Stress State Properties for Refined Deformation Estimates for Liquefaction and Slope Stability Evaluations

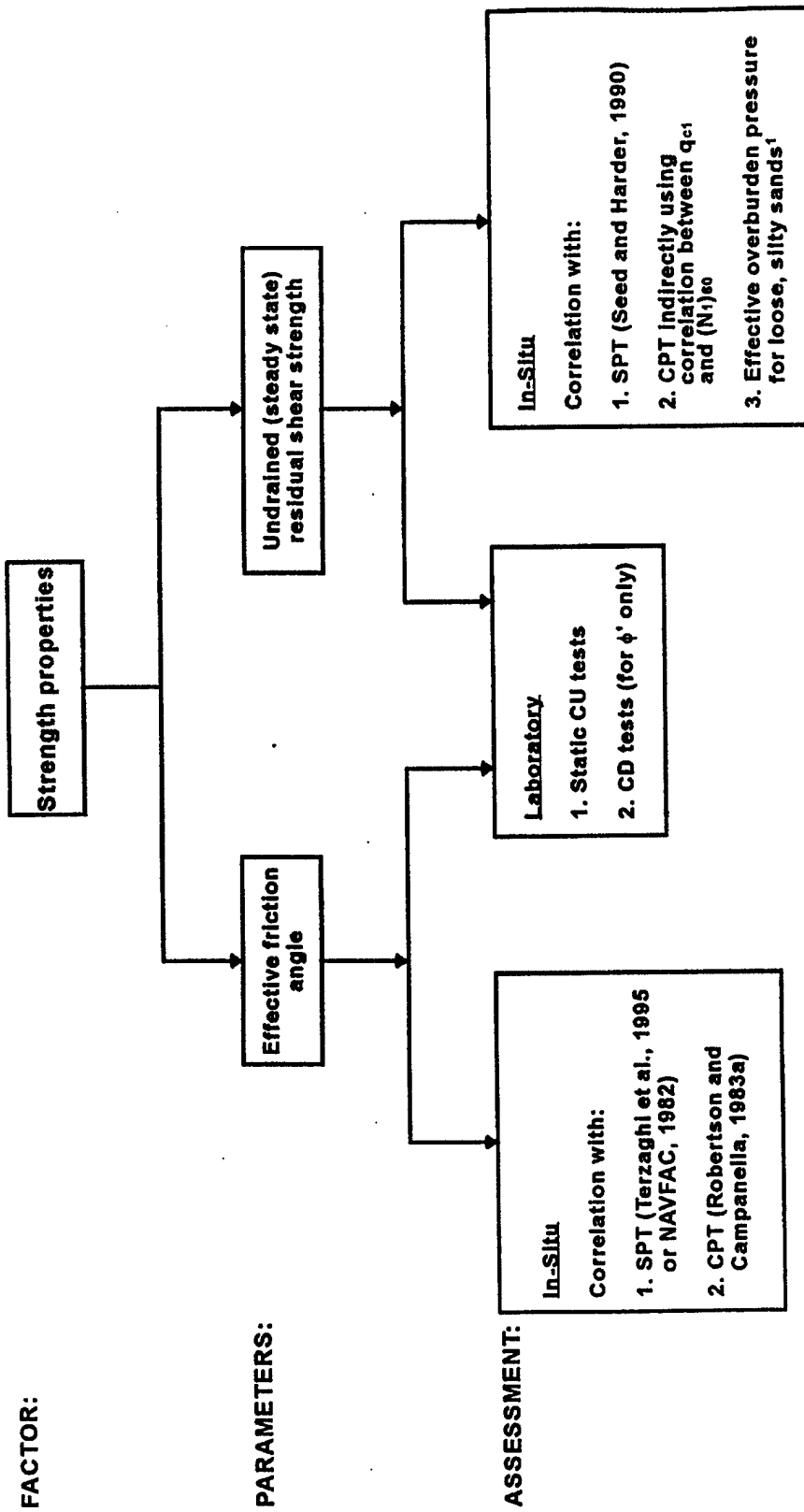

Notes:

1. Recommended Su/p ratio per Baziar et al. (1995): $Su/p \approx 0.145$ or $Su/p \approx 0.11 + 0.0037(PI)$

FIGURE 25 Assessment Methods for Strength Properties for Refined Deformation Estimates for Liquefaction and Slope Stability Evaluations

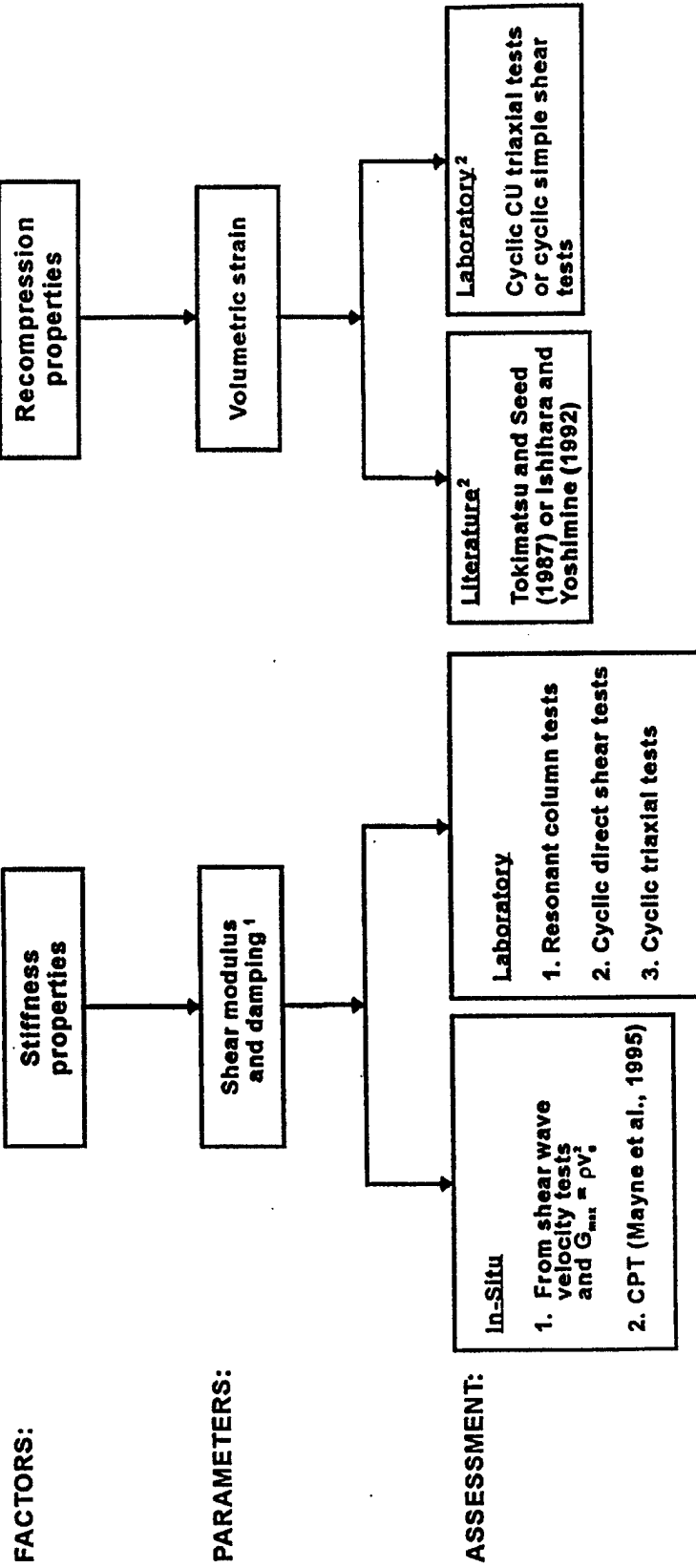

Notes:

1. Variation of shear modulus and damping with shear strain for "clean" sands can be determined using curves by Idriss (1990). Curves by Vucetic and Dobry (1991) can be used for plastic soils.
2. Tokimatsu and Seed (1987) and Ishihara and Yoshimine (1992) procedures developed for "clean" sands. For other soil types susceptible to liquefaction, volumetric strains can be estimated in the laboratory using results from cyclic CU triaxial tests on "undisturbed" samples subjected to cyclic stress levels causing liquefaction. Samples are reconsolidated after liquefaction to obtain volumetric strain data.

FIGURE 26 Assessment Methods for Stiffness and Recompression Properties for Refined Deformation Estimates for Liquefaction and Slope Stability Evaluations

CHAPTER 3

IF GROUND IMPROVEMENT IS NECESSARY, WHAT METHODS ARE AVAILABLE?

Many methods for ground modification and improvement are available, including dewatering, compaction, preloading with and without vertical drains, admixture stabilization, grouting of several types, deep mixing, deep densification, and soil reinforcement. Many of these techniques, such as dewatering, compaction, precompression, and some types of grouting, have been used for many years. However, there have been rapid advances in the areas of deep densification (vibrocompaction, deep dynamic compaction, compaction piles, explosive densification), jet and compaction grouting, deep mixing, and stone column systems in recent years. These methods have become practical and economical alternatives for many ground improvement applications. While most of these technologies were originally developed for uses other than seismic risk mitigation, many of the recent advances in the areas of deep densification, jet and compaction grouting, and deep mixing methods have been spurred on by the need for practical and cost effective means for mitigating seismic risks. Many of these methods have been applied to increase the liquefaction resistance of loose, saturated, cohesionless soils.

Table 3 contains a list of potentially applicable ground improvement methods for civil works structures. Various purposes for ground improvement are indicated, along with methods that may be applicable for each purpose. Several different methods may be suitable for each potential application. Selection of the most appropriate method for a particular purpose will depend on many factors, including the type of soil to be improved, the level of improvement needed, the magnitude of improvement attainable by a method, and the required depth and areal extent of treatment. The applicable grain size ranges for various soil improvement methods are shown in Figure 27. The remaining factors are discussed further in subsequent chapters.

Figure 27. Applicable Grain Size Ranges For Soil Improvement Methods.

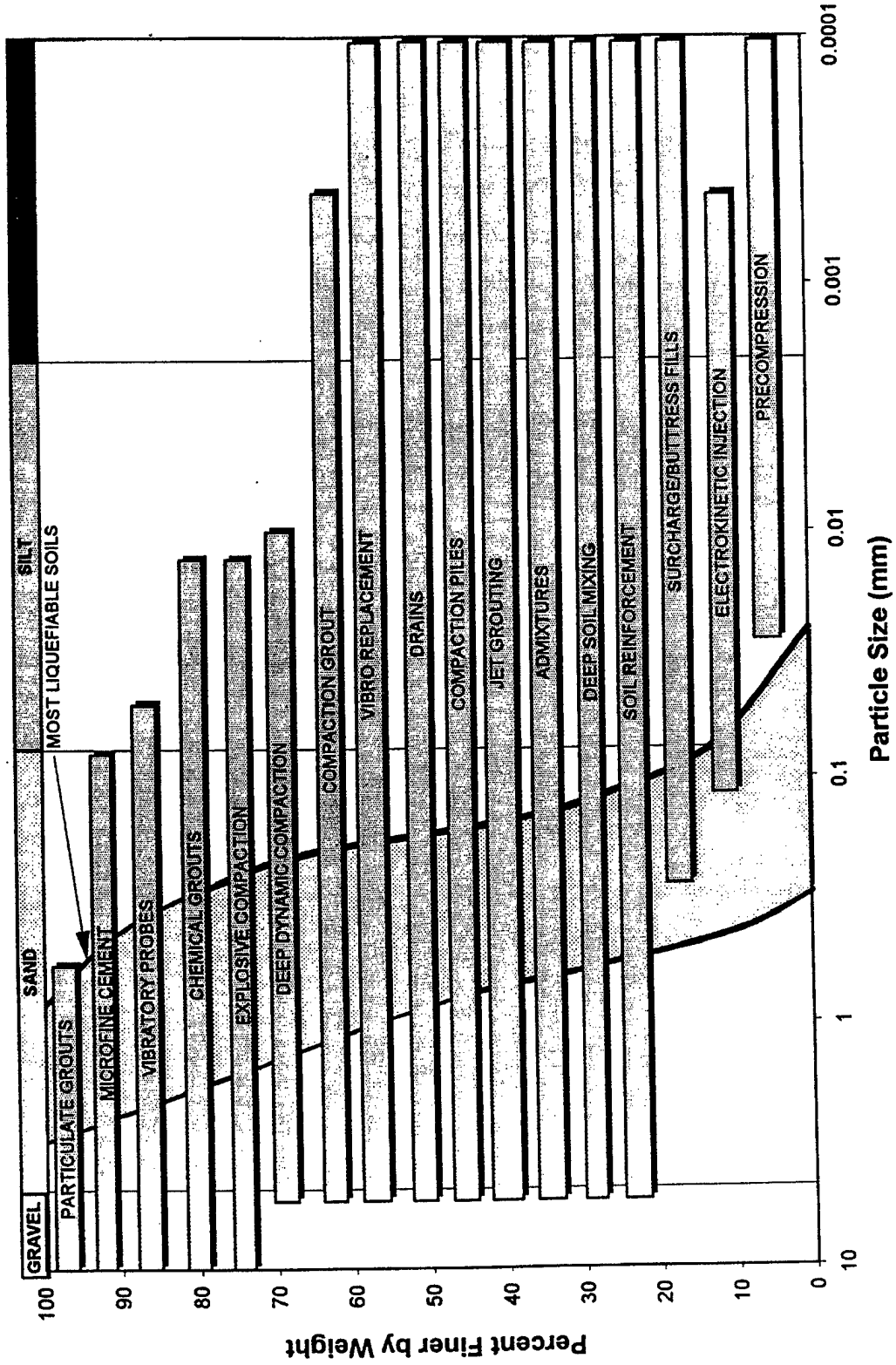

An important factor in selection of a suitable ground improvement method is the accessibility of the site, particularly if the site is already developed. When ground improvement is needed on large, open and undeveloped sites, there are typically more and less expensive options available than at sites that are small or have constraints such as existing structures or facilities. Ground improvement methods that are potentially suitable and economical for use on large, open, undeveloped sites are summarized in Table 4. A similar summary of ground improvement methods that may be applicable for use at constrained or developed sites is contained in Table 5. For each method, information is provided regarding suitable soil types, effective depth of treatment, typical layout and spacing, attainable improvement, advantages, limitations and prior experience. A summary of approximate costs for various ground improvement options is presented in Table 6.

Tables 3, 4, and 5 can be used to select options for ground improvement at a particular site. These options can then be narrowed down based on the design considerations presented in the next chapter. Table 6 can be used to estimate the approximate costs for various ground improvement methods.

Brief description of each of the methods are given below. More detailed discussions may be found in Mitchell (1981), FHWA (1983, 1986a, 1986c, 1996a, 1996b, 1998), Hausmann (1990), Mitchell and Christopher (1990), Narin van Court and Mitchell (1994, 1995), Hayward Baker (1996), and ASCE (1997).

Soil Replacement

Soil replacement involves excavating the soil that needs to be improved and replacing it. The excavated soil can sometimes be recompacted to a satisfactory state or it may be treated with admixtures and then be replaced in a controlled manner. It can also be replaced with a different soil with more suitable properties for the proposed application.

Admixture Stabilization

Admixture stabilization consists of mixing or injecting admixtures such as cement, lime, flyash or bentonite into a soil to improve its properties. Admixtures can be used to increase the strength, decrease the permeability or improve the workability of a soil. Admixtures can fill voids, bind particles, or break down soil particles and form cement. The general process of admixture stabilization consists of: (1) excavating and breaking up the soil, (2) adding the stabilizer and water, if necessary, (3) mixing thoroughly, and (4) compacting the soil and allowing it to cure. Admixture stabilization is discussed in detail in Hausmann (1990).

Roller Compacted Concrete

Roller compacted concrete (RCC) is a material that has useful applications for ground improvement. RCC is essentially no-slump concrete composed of a blend of coarse aggregate, fine aggregate, cement and water. It can be used to construct earth dams with steep slopes, to provide overtopping protection for existing earth dams, and to buttress existing slopes. It is placed and spread using conventional earth moving equipment, compacted with vibratory rollers and allowed to cure. During curing, the RCC hydrates and hardens into weak concrete. In recent years, many dams have either been constructed or rehabilitated using RCC. Use of RCC for embankment overtopping protection is discussed in *Roller Compacted Concrete III* (1992) and by McLean and Hansen (1993). Construction of dams using RCC is discussed in *Roller Compacted Concrete II* (1988) and *Roller Compacted Concrete III* (1992).

Deep Dynamic Compaction

Deep dynamic compaction (DDC), also called heavy tamping, consists of repeated dropping of heavy weights onto the ground surface to densify the soil at depth, as shown in Figure 28. For unsaturated soil, the process of DDC is similar to a large-scale Proctor compaction test. For loose, fully saturated, cohesionless soils, the impact from the weight liquefies the soil and the particles are rearranged in a denser, more stable configuration. At developed sites, a

buffer zone around structures of about 30 to 40 meters is required. A typical DDC program involves weights of 10 to 30 tons dropped from heights of 15 to 30 meters at grid spacings of 2 to 6 meters. A photograph of the DDC process is shown in Figure 28. DDC works best on sands and silty sands, with a maximum effective densification depth of about 10 meters. The maximum improvement occurs in the upper two-thirds of the effective depth. The relationship between the effective depth, the weight and the height of the drop can be expressed as:

$$D = (0.3 \text{ to } 0.7) * (WH)^{1/2}$$

where D = maximum depth of improvement, m

W = falling weight, metric tons

H = height of drop, m.

The lower values for the coefficient generally apply to silty sands, whereas, clean, coarse, cohesionless soils are densified to a greater effective depth for a given value of $W*H$. DDC is discussed in greater detail in Mitchell (1981), FHWA (1986a), and Hayward Baker (1996).

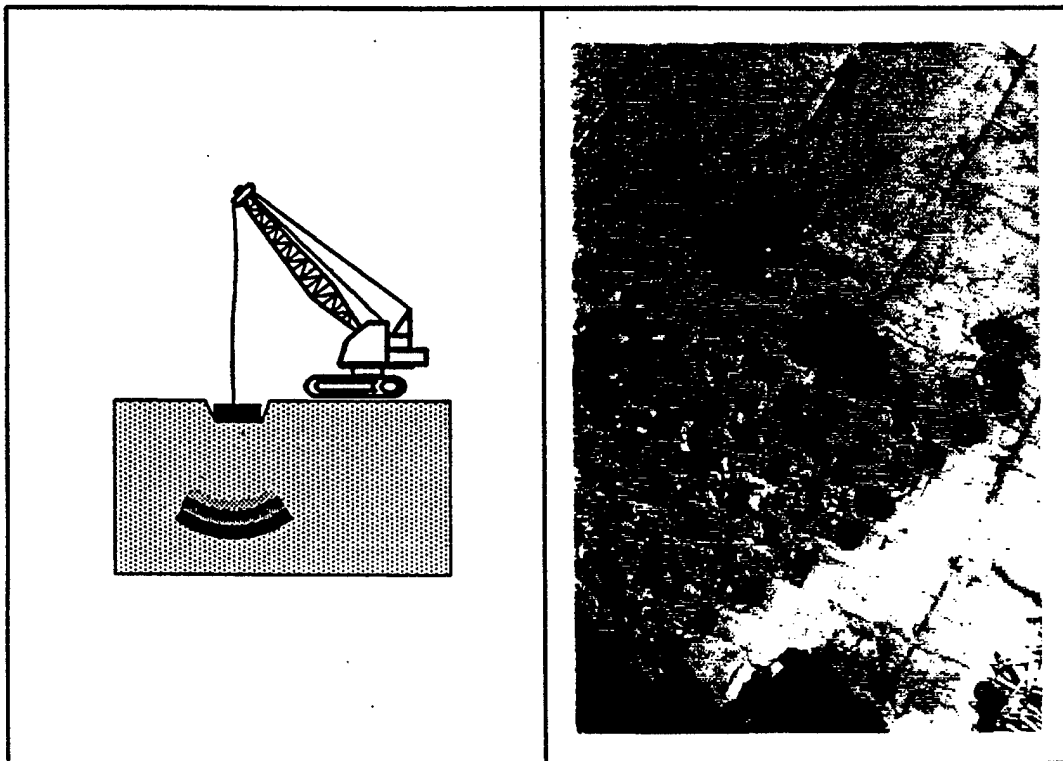

Figure 28. The dynamic compaction process (from Hayward Baker, 1996).

Vibrocompaction and Vibrorod

Vibrocompaction methods use vibrating probes (typically having a diameter of about 0.4 m) to densify the soil. A sketch showing the vibrocompaction process is shown in Figure 29. The probe is usually jetted into the ground to the desired depth of improvement and vibrated during withdrawal, causing densification. The soil densifies as the probe is repeatedly inserted and withdrawn in about 1 m increments. The cavity that forms at the surface is backfilled with sand or gravel to form a column of densified soil. Vibrocompaction methods are most effective for sands and gravels with less than about 20 percent fines, as shown in Figure 30.

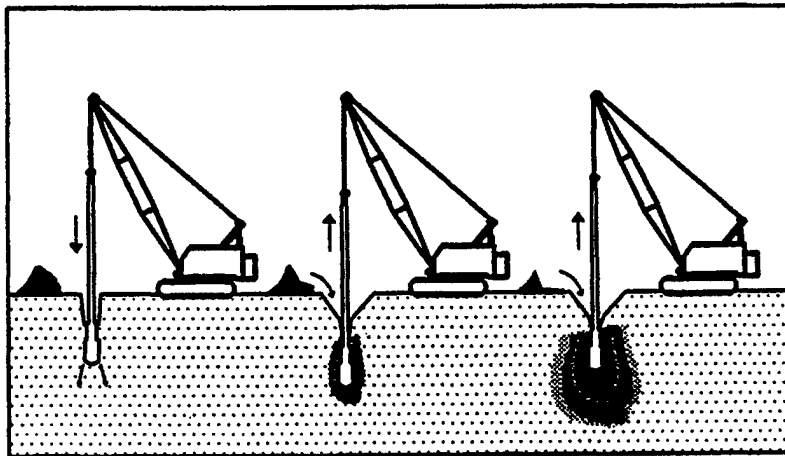

Figure 29. The vibrocompaction process (Hayward Baker, 1996)

When vibrocompaction is used for large areas, it is typically performed using either a triangular or rectangular grid pattern, with probe spacings in the range of 1.5 m to 3 m on centers. The spacing depends on several factors, including the soil type, backfill type, probe type and energy, and the level of improvement required. An approximate variation of relative density with effective area per compaction probe for a sand backfill is shown in Figure 31 (FHWA, 1983). While field tests are usually done to finalize the design, Figure 31 can be used for preliminary probe spacings. This figure can also be used for preliminary design of stone columns, which is discussed in the next section. Advantages of vibrocompaction are that the vibrations

felt on or near the site are significantly less than caused by deep dynamic compaction or explosive compaction and more uniform densification is obtained. On the other hand, the cost is usually greater. Additional information is available in Mitchell (1981), Hausmann (1990), and Hayward Baker (1996).

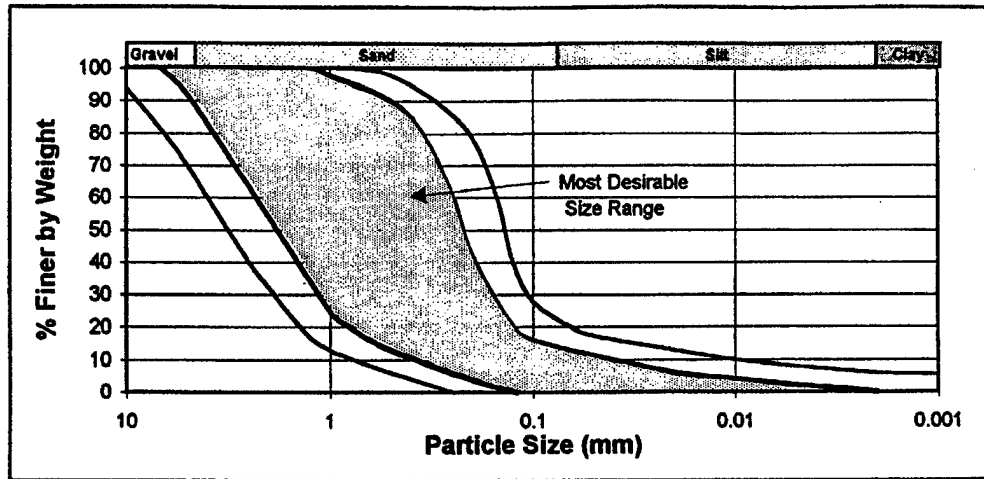

Figure 30. Range of particle size distributions suitable for densification by vibrocompaction.

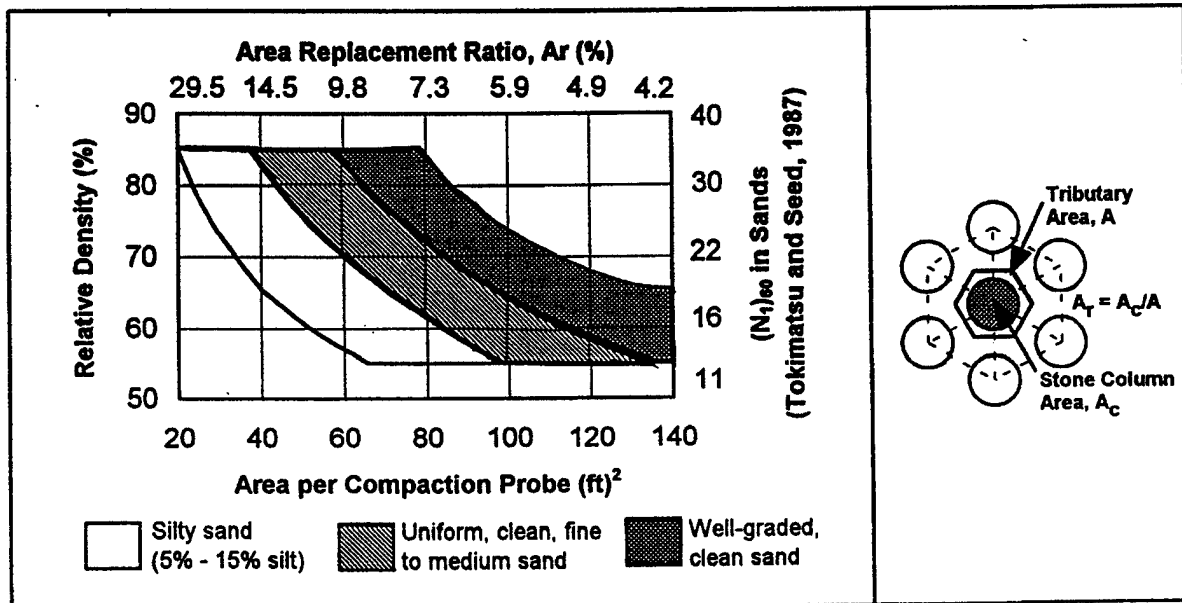

Figure 31. Approximate variation of relative density with tributary area or area replacement ratio (after FHWA, 1983).

Stone Columns (Vibroreplacement)

Stone columns are installed using a process similar to vibrocompaction, except that a gravel backfill is used, and they are usually installed in slightly cohesive soils or silty sands rather than clean sands. In the dry process, a cylindrical cavity is formed by the vibrator, that is filled from the bottom up with gravel or crushed rock. Compaction is by vibration and displacement during repeated $0.5\pm$ m withdrawals and insertions of the vibrator. Stone columns are usually about 1 m in diameter, depending on the soil conditions, equipment and construction procedures. They are usually installed in square or triangular grid patterns, but may also be used in clusters and rows to support footings and walls. Center-to-center column spacings of 1.5 to 3.5 m are typical. Figure 31 may be used for preliminary design using the area replacement ratio axis. The area replacement ratio is defined as the area of the stone column to the tributary area per stone column. For foundation applications, coverage should be extended beyond the perimeter of the structure to account for stress spread with depth. A drainage blanket of sand or gravel 0.3 m or more in thickness is usually placed over the top of the treatment area. This blanket also serves to distribute stresses from structures above. Additional details regarding stone columns are discussed in Mitchell (1981), Hausmann (1990), and Hayward Baker (1996).

Gravel Drains

Gravel drains are a type of stone column proposed for use in liquefiable soils to mitigate liquefaction risk by dissipation of excess pore water pressures generated during earthquakes (ASCE, 1997). They have been proposed for use in two ways: (1) as the sole treatment method for liquefiable zones and (2) as a perimeter treatment around improved zones to intercept pore pressure plumes from adjacent untreated ground. A typical layout for gravel drains is shown in Figure 32. Gravel drains are constructed in the same manner as stone columns, but are installed in cohesionless deposits. As the gravel is densified during vibro-replacement, there is mixing of the sand from the formation with the gravel in the drain. The degree of mixing has a strong influence on the final permeability of the gravel drain.

Seed and Booker (1977) first proposed design methods for gravel drains to prevent liquefaction of sands. They assumed that drainage would occur radially towards the center of the column if the drain permeability were at least 200 times the native soil permeability and that drain resistance could be neglected. In practice, however, seepage in the drain occurs vertically, so the drainage path length is much longer than originally assumed by Seed and Booker and drain resistance becomes an important factor in design. Design diagrams that consider the drainage path length and drain resistance were presented by Onoue (1988). Boulanger et al. (1998) performed designs using both methods and found that the methods agree when drain resistance is negligible. However, they also found that a drain permeability of 200 times the soil permeability was not sufficient to eliminate the effects of drain resistance. Therefore, they suggest that the diagrams presented by Onoue (1988) be used to include the effects of drain resistance in design of gravel drains.

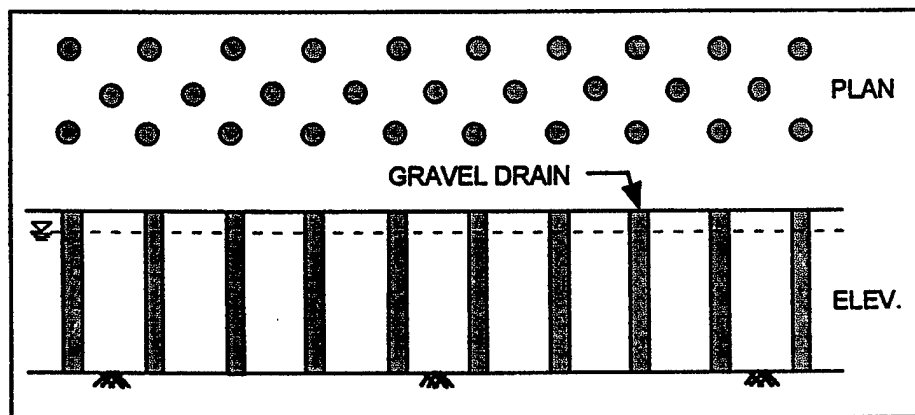

Figure 32. Arrangement of gravel drains (after Seed and Booker, 1977).

A detailed discussion of design and construction issues regarding gravel drains is presented by Boulanger et al. (1998). Intermixing of the native soil and the drain material can cause the permeability of the resultant drain to be less than 100 times the permeability of the native soil. Construction defects can result in zones of low permeability. Therefore, it is recommended that densification be the primary treatment goal when gravel columns are used and that drainage be considered a secondary benefit. It is noted, however, that row(s) of gravel drains used

around the perimeter of a densified zone can be beneficial in intercepting excess pore pressure plumes from adjacent liquefied soil.

Sand and Gravel Compaction Piles

Compaction piles densify the soil by two mechanisms: (1) displacement of a volume of soil equal to the pile volume and (2) densification of the soil due to vibrations induced by the pile driving. They are typically spaced 1 to 3 m on center. For preliminary design in loose sand, the following guideline may be used. To increase the average density of loose sand from an initial void ratio e_o , to a void ratio e , assuming that installation of a sand pile causes compaction only in a lateral direction, the pile spacings may be determined using

$$S = d \left(\frac{\pi(1 + e_o)}{e_o - e} \right)^{1/2}$$

for sand piles in a square pattern, Figure 33 (a) and

$$S = 1.08 d \left(\frac{\pi(1 + e_o)}{e_o - e} \right)^{1/2}$$

for piles in a triangular pattern, Figure 33 (b), in which d is the sand pile diameter (up to 800 mm) (Mitchell, 1981). Compaction piles are often slow to install and relatively expensive. A Franki pile is a type of compaction pile in which a falling weight is used to drive the backfill out the bottom of a large diameter pipe. Additional detail on sand and gravel compaction piles can be found in Mitchell (1981).

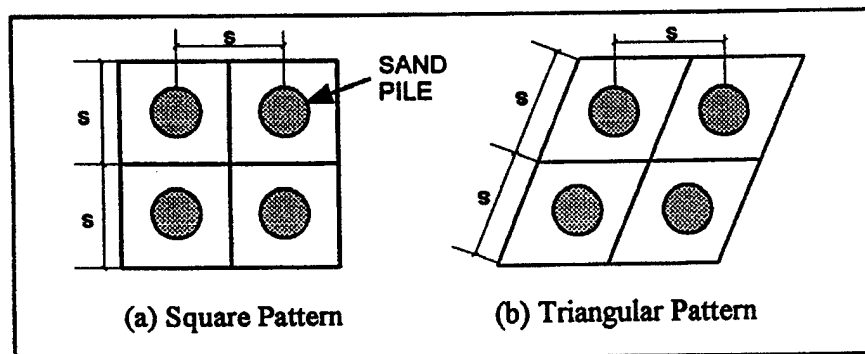

Figure 33. Usual compaction pile patterns.

Explosive Compaction

In explosive compaction, densification occurs after a charge is detonated below the ground surface. The detonation induces liquefaction in the soil, which then recompacts to a denser, more stable fabric under the pressures induced by both the blast and by gravity. If a partly saturated soil is prewetted before the charges are detonated, the process is termed hydroblasting. Hydroblasting is sometimes used to treat collapsible soils. A typical layout for explosive compaction is shown in Figure 34. Explosive compaction has an unlimited effective depth and is best suited for clean sands and silty sands with initial relative densities of less than about 50 to 60 percent. The post-densification improvement in strength and stiffness is usually time-dependent and may require several weeks to fully develop.

A typical blasting program consists of charges spaced at 3 to 8 m in developed areas and 8 to 15 meters in remote areas, with charge weights between 2 and 15 kilograms. The total explosive use is usually 40 to 80 g/m³. For soil layers less than 10 m thick, the charges are usually placed at a depth between one-half and three-quarters the thickness of the layer to be treated, with a depth of two-thirds the layer thickness common. If a layer is more than 10 m thick, it is recommended that it be divided into sublayers, where each sublayer is treated separately with decked charges (Narin van Court and Mitchell, 1994). The charges in each sublayer can be set off in sequence from top to bottom or bottom to top, and there is no definitive evidence that one sequence is more effective than the other.

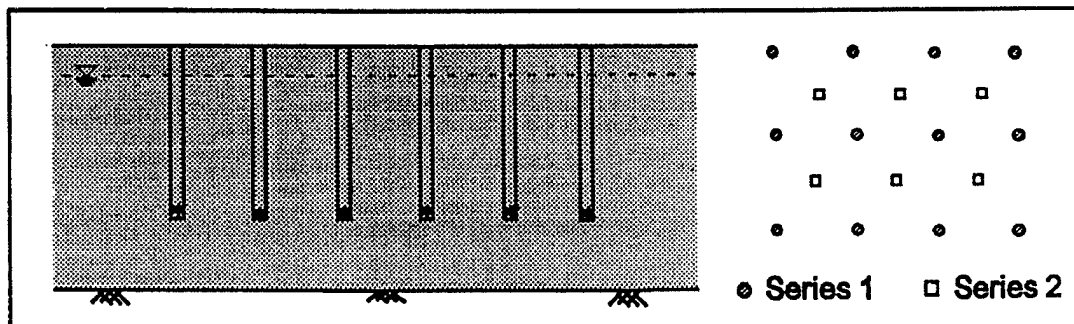

Figure 34. Typical layout for explosive compaction program.

For any layer thickness, the treatment area typically needs to be treated with 2 or 3 series of charges, with each series of charges separated by a period of hours or days. Surface settlement of 2 to 10 percent can be expected, depending on the amount of explosives used and the initial properties of the soil and site. A field testing program is usually performed for the final design. For additional information on explosive compaction, consult Narin van Court and Mitchell (1994, 1995).

Permeation Grouting

Permeation grouting is a process by which the pore spaces in soil or the joints in rock are filled with grout, as depicted in Figure 35. Injection pressures are usually limited to prevent fracture or volume change in the formation. One rule of thumb for maximum injection grouting pressures is 20 kPa per meter of depth (1 psi/ft). Either particulate or chemical grouts can be used. The process is limited to relatively coarse-grained soils, because the grout must be able to flow through the formation to replace the fluid in the void spaces or joints. Particulate grouts, such as cement or bentonite, are used for soils no finer than medium to coarse sands, since the particles in the grout must be able to penetrate the formation. Use of micro-fine cement enables penetration of somewhat finer-grained soil than can be treated using ordinary Portland cement. Chemical grouts, usually silicates, can be used in formations with smaller pore spaces, but are still limited to soils coarser than fine sands. The typical spacing for penetration grouting holes is between about 4 to 8 feet. For water cutoff applications, two or three rows of grout holes are usually required to form an effective seepage barrier. Penetration grouting can also be used for ground strengthening and liquefaction mitigation. Whereas seepage control requires essentially complete replacement of the pore water by grout, effective strengthening is possible with incomplete replacement. Additional references on permeation grouting include Karol (1990) and Xanthakos et al. (1994). Case histories on chemical grouting for mitigation of liquefaction risk can be found in Graf (1992b).

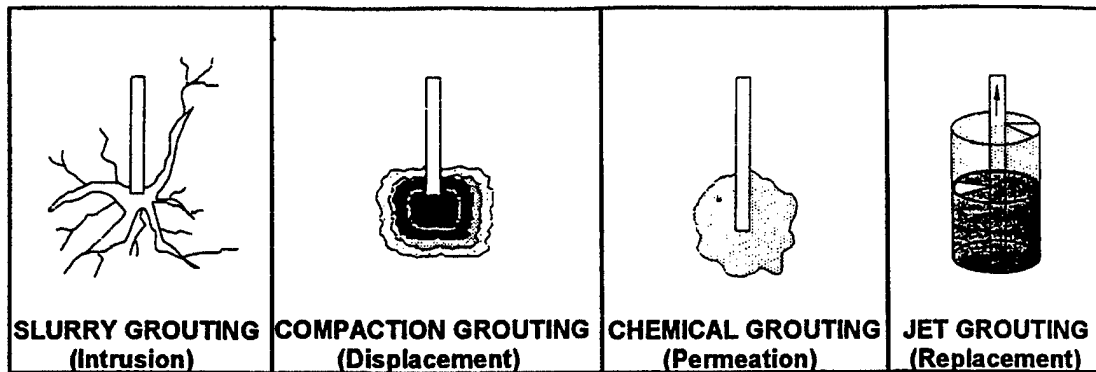

Figure 35. Types of grouting (Hayward Baker, 1996).

Compaction Grouting

Compaction grouting consists of injecting a very-low slump mortar into loose soils and cavities. The grout forms a bulb which expands against the surrounding soil, causing densification and displacement to occur (Figures 35 and 36). Unlike penetration grouting, the grout does not penetrate the soil pores in compaction grouting. The grout acts as a radial hydraulic jack to compress the surrounding soil. The grout is usually a mix of sandy soil with enough fines to bind the mix together, cement, and water. A typical compaction grout mix consists of about 3 parts sand to 1 part cement, although cement is not always used. The grout forms a bulb up to about 1 m in diameter, that is relatively strong and incompressible after it hardens. The process causes an overall decrease in the void ratio of the formation. Compaction grouting is most effective for loose granular soils, collapsible soils, and loose, unsaturated fine-grained soils.

A typical compaction grouting program consists of pipe spacings between 3 to 15 feet, with 5 to 7 feet spacing common. The pumping rate may vary from 0.5 to 10 cubic feet per minute, depending on the type of soil being treated. The replacement factor, which is the percentage of total ground volume that is filled with grout, ranges from about 3 to 12 percent. Additional information on compaction grouting can be found in Graf (1992a) and Warner et al. (1992). Details of compaction grouting for liquefaction mitigation can be found in Graf (1992b) and Boulanger and Hayden (1995).

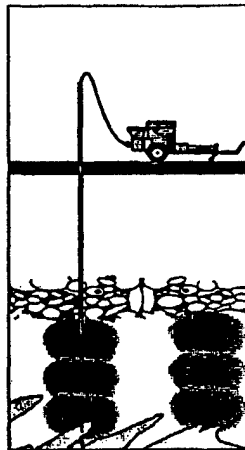

Figure 36. Compaction grout bulb construction (ASCE, 1997).

Jet Grouting

Jet grouting is a process in which a high-pressure water jet is used to erode the native soil and mix it or replace it with a stabilizer such as cement or bentonite, as depicted in Figure 37. The grout-soil mixture forms high strength or low permeability columns, panels or sheets, depending on the orientation and rotation of the jets as they are withdrawn from the ground. Columns of up to about 1 m diameter are typical, although much larger columns are possible using special equipment. Jet grouting can be used in most soil types, although it works best in soils that are easily eroded, such as cohesionless soils. Cohesive soils, especially highly plastic clays, can be difficult to erode and can break up in chunks. The return velocity of the drilling fluid is usually not large enough to remove chunks of clay, so the quality of the grout-soil mixture could be compromised and hydrofracturing could occur in highly plastic clays (ASCE, 1997). A drawback of jet grouting is that it is very expensive and that special equipment is required. However, one advantage is that treatment can be restricted to the specific layer requiring improvement. Another advantage is that the injection rods can be inclined, so it is useful for grouting under structures or existing facilities. Burke and Welsh (1991) and Xanthakos et al. (1994) can be consulted for additional information regarding jet grouting.

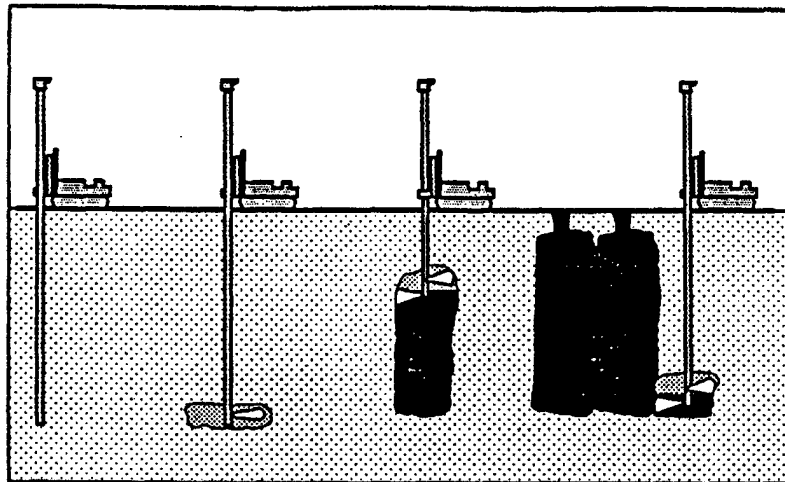

Figure 37. The jet grouting process (Hayward Baker, 1996).

Deep Soil Mixing

In the deep soil mixing technique, admixtures are injected into the soil at the treatment depth and mixed thoroughly using large-diameter single- or multiple-axis augers to form columns or panels of treated material. The mix-in-place columns can be up to 1 m or more in diameter. The treatment modifies the engineering properties of the soil by increasing strength, decreasing compressibility and decreasing permeability. Typical admixtures are cement and lime, but slag or other additives can also be used. The mix-in-place columns can be used alone, in groups to form piers, in lines to form walls, or in patterns to form cells. The process can be used to form soil-cement or soil-bentonite cutoff walls in coarse-grained soils, to construct excavation support walls, and to stabilize liquefiable ground. Deep mixing for mitigation of liquefaction risk at Jackson Lake Dam is illustrated in Figure 38. A detailed discussion of deep mixing is presented in ASCE (1997).

Mini-piles

Mini-piles, also known as micro-piles or root piles, are “small-diameter, bored, grouted-in-place piles incorporating steel reinforcement” (ASCE, 1997). Mini-piles can be used to with-

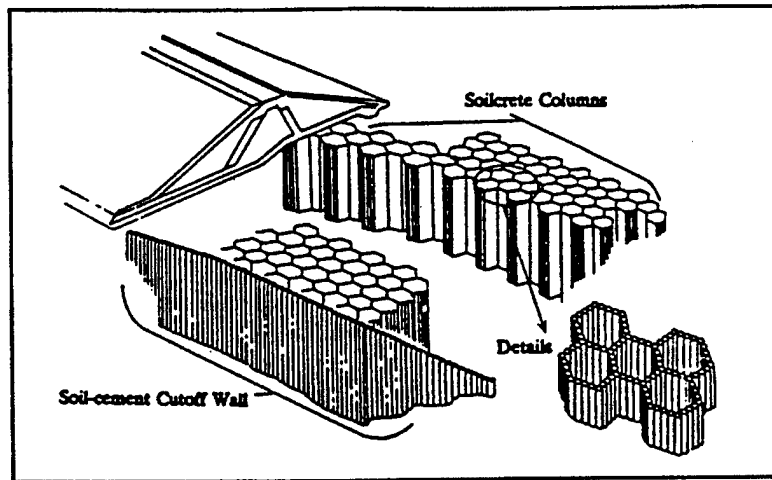

Figure 38. DSM for Jackson Lake Dam Modification Project (Taki and Yang, 1991).

stand axial loads and/or lateral loads, either for the support of structures or the stabilization of soil masses. Various applications for micro-piles are shown in Figure 39. Diameters are usually in the range of 100 to 250 mm, with lengths up to 20 to 30 m and capacities from about 100 to 300 kN (67 to 225 kips). Mini-piles can be installed both vertically and on a slant, so they can be used for underpinning of existing structures.

Conventional concrete cast-in-place piles generally rely on the concrete to resist the majority of the applied load. In contrast, mini-piles often contain high capacity steel elements that occupy up to 50 percent of the borehole volume. Therefore, the steel element is the primary

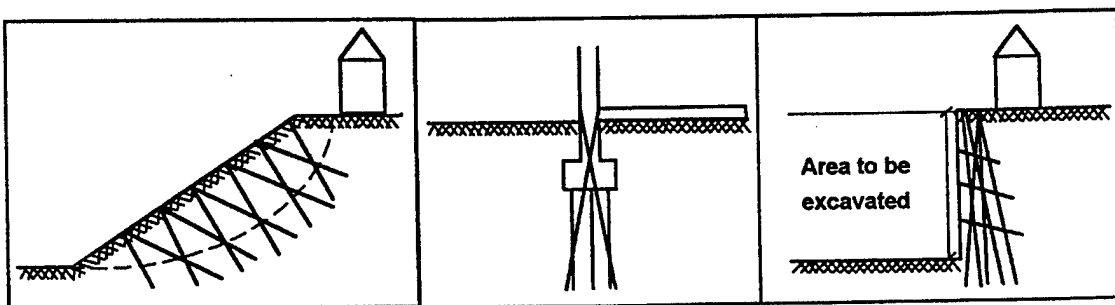

Figure 39. Mini-pile applications (modified from Lizzi, 1983).

load bearing component, and can develop high capacities, while the grout serves to transfer the load from the steel to the soil. Additional information on mini-piles can be obtained from Xanthakos et al. (1994). Case histories are discussed in Bruce (1991). Information on design can be found in Volume 2 of the FHWA State of Practice Report (1996a).

Soil Nailing

Soil nailing consists of a series of inclusions, usually steel rods, centered in a grout-filled hole about 6 inches in diameter in the ground to be supported. By spacing the inclusions closely, a composite structural entity can be formed. The "nails" are usually reinforcing bars 20-30 mm in diameter that are grouted into predrilled holes or driven using a percussion drilling device at an angle of 10 to 15 degrees down from the horizontal. Drainage from the soil is provided with strip drains and the face of the excavation is protected with a shotcrete layer.

The purpose of soil nailing is to improve the stability of slopes or to support slopes and excavations by intersecting potential failure planes. An example of soil nailing for excavation support is shown in Figure 41. There are two mechanisms involved in the stability of nailed soil structures (Mitchell and Christopher, 1990). Resisting tensile forces are generated in the nails in the active zone. These tensile forces must be transferred into the soil in the resisting zone

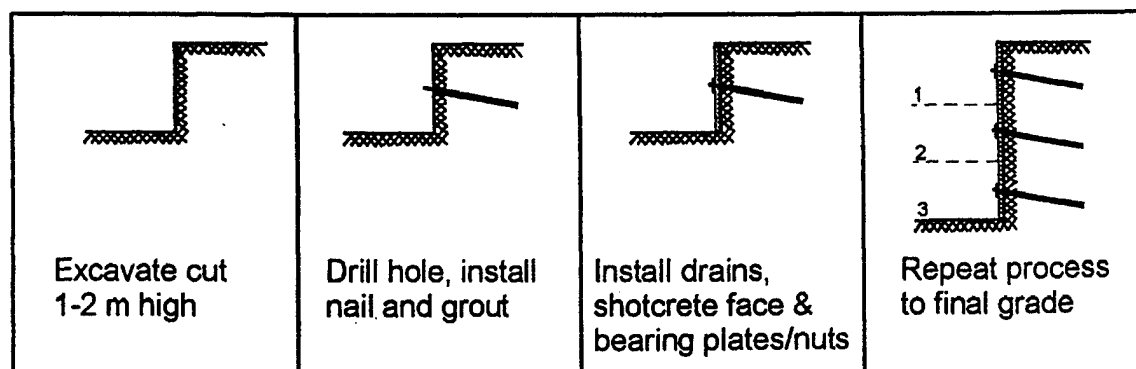

Figure 40. Soil nailing for excavation support (after Walkinshaw and Chassie, 1994).

through friction or adhesion mobilized at the soil-nail interface. The second mechanism is the development of passive resistance against the face of the nail.

Soil nailing works best in dense granular soil and stiff, low plasticity silty clay soils. In stiff soils, the maximum facing displacement is about 0.3 percent. Current design procedures for soil nailed walls are included in FHWA (1996b).

Prefabricated Vertical (PV) Drains, with or without surcharge fills

Prefabricated vertical (PV) drains, also known as wick drains, are typically installed in soft, cohesive soil deposits to increase the rate of consolidation settlement and corresponding strength gain. The rate of consolidation settlement is proportional to the square of the length of the drainage path to the drain. Installing vertical drains shortens the drainage path, which causes an increase in the rate of settlement. Geocomposites are widely used as drains because they are relatively inexpensive, economical to install and have a high flow capacity. Geocomposite drains consist of a plastic waffle core which conveys the water and a geotextile filter to protect the core from clogging. In selecting a drain, it is important to choose one with enough capacity. Drains are typically spaced in a triangular or rectangular configuration. A sand blanket is usually placed on the surface of the consolidating layer to facilitate drainage. For additional information on engineering assessment and design of vertical drains, the 1986 FHWA publications titled *Prefabricated Vertical Drains* and *Geocomposite Drains* may be consulted. A discussion of the updates in PV drains in the past ten years can be found in ASCE (1997).

Surcharge preloading can be used in conjunction with vertical drains to increase the magnitude of settlement prior to construction, as shown in Figure 41. Surcharge preloading consists of placing a surcharge load over the footprint of the proposed facility prior to construction. The surcharge load causes consolidation settlement to occur. It can be accomplished with surcharge fills, water in tanks and ponds, by lowering the groundwater table or by electroosmosis.

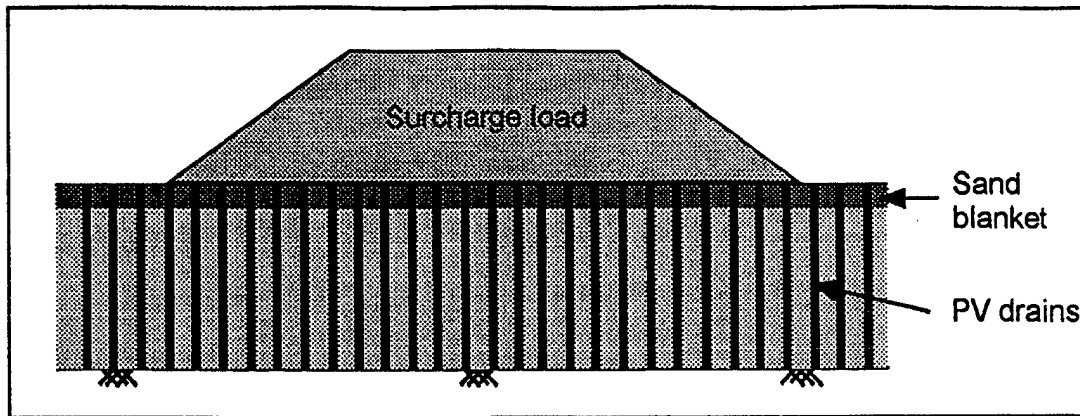

Figure 41. PV drains with surcharge load.

A new application for PV drains is in the area of mitigation of liquefaction risk (ASCE, 1997). PV drains have the potential to provide liquefaction resistance by improving drainage and/or adding reinforcement. PV drains were installed in conjunction with stone columns in a test section at Salmon Lake Dam in Washington (Luehring, 1997). The purpose of the installation was for liquefaction mitigation of non-plastic silty soils. The PV drains were used to improve drainage, provide relief of excess pore pressure and to prevent disturbance or fracturing of the foundation soils. The drains were installed prior to stone column construction. The columns were installed using the dry, bottom-feed method, which presents concerns with respect to disturbance or fracture of the foundation soils being treated, as well as the adjacent foundation soils. During construction of the stone columns, air and water were ejected from most of the wick drains. The study concluded that the wick drains relieved most of the excess air and water pressures during construction, thus protecting the dam and foundation materials immediately below the dam from disturbance.

Electroosmosis

If a DC electric potential is applied to a saturated clay soil, the cations will be attracted to the cathode and the anions will be attracted to the anode. The cations and anions will carry their water of hydration with them as they move and move additional water by viscous drag. Due

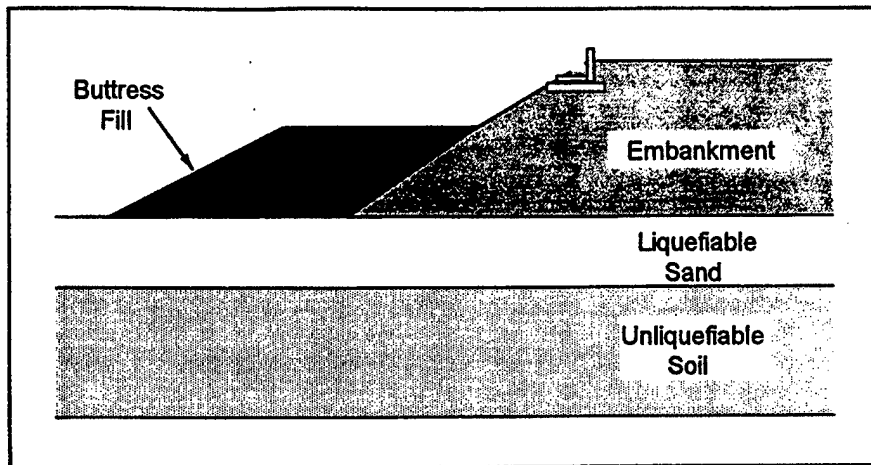

Figure 42. Buttress fill at toe of embankment.

to the net negative charge of the clay particles, there are more mobile cations than anions, so the net flow of pore water will be toward the cathode. If the cathode is a wellpoint, the water collected at the cathode can be removed and the soil between the electrodes will consolidate. Consolidation will be greatest at the anode and least near the cathode. No consolidation will occur at the cathode itself. The process of electroosmosis will result in a lower moisture content, lower compressibility and increased strength. There may be an additional increase in strength and a decrease in plasticity due to electrochemical hardening, which occurs when the application of a DC electric potential to a saturated clay causes electrode corrosion, ion exchange, and mineral alteration. Electroosmosis and electrochemical hardening are discussed by Mitchell (1993).

Buttress Fills

A buttress fill may be used to improve the stability of a slope or increase the resistance to liquefaction by adding weight to the system, as shown in Figure 42. For a slope, the buttress adds weight which increases the resisting force and increases the length of the failure surface. For ground susceptible to liquefaction, the buttress also serves to increase the confining pressure, thereby increasing the resistance to liquefaction.

Biotechnical Stabilization and Soil Bioengineering

Biotechnical stabilization and soil bioengineering can be used to stabilize slopes against erosion and shallow slope failures. The biotechnical stabilization method consists of using live vegetation in combination with inert structural or mechanical components, such as retaining structures, revetments and ground cover systems (ASCE, 1997). For example, plants can be established in the front openings of gabion walls and cellular grids or on the benches of tiered retaining walls. The vegetation and mechanical elements work together as an integrated system to provide erosion protection or slope stabilization. Soil bioengineering is the use of live plants alone to serve as soil reinforcement, hydraulic drains and barriers to earth movement. An example of slope stabilization by brush layering is shown in Figure 43. Bioetechanical stabilization and soil bioengineering are discussed in Gray and Sotir (1996). This method is applicable for river and stream banks. It should not be used as part of the physical flood protection (levees, etc.).

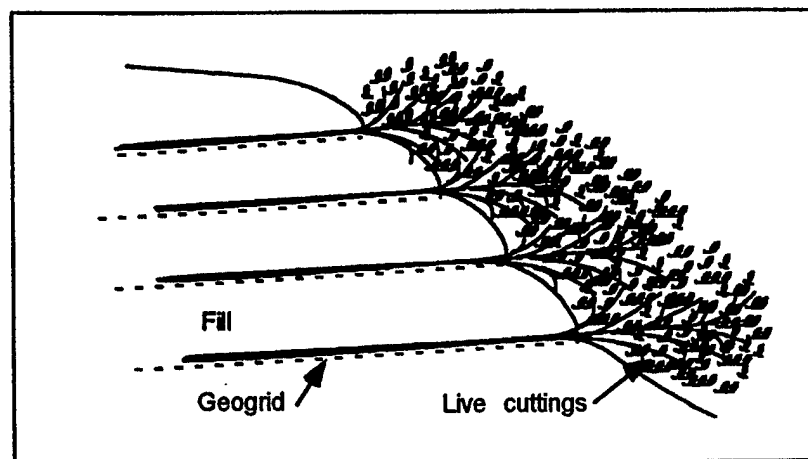

Figure 43. Biotechnical stabilization by brush layering (after Gray and Sotir, 1996).

Table 3 - Potentially Applicable Ground Improvement Methods for Civil Works Structures

Purpose	Method
<ul style="list-style-type: none"> • Increase resistance to liquefaction • Reduce movements 	<ul style="list-style-type: none"> • Vibrocompaction, vibrorod • Stone columns • Deep dynamic compaction • Explosive compaction • Gravel drains • Deep soil mixing • Penetration grouting • Jet grouting • Compaction grouting • Sand and gravel compaction piles
<ul style="list-style-type: none"> • Stabilize structures that have undergone differential settlement 	<ul style="list-style-type: none"> • Compaction grouting • Penetration grouting • Jet grouting • Mini-piles
<ul style="list-style-type: none"> • Increase resistance to cracking, deformation and/or differential settlement • Reduce immediate settlement 	<ul style="list-style-type: none"> • Compaction grouting • Penetration grouting • Jet grouting • Mini-piles • Vibrocompaction, vibrorod • Deep soil mixing • Deep dynamic compaction • Jet grouting • Explosive compaction • Sand and gravel compaction piles • Compaction grouting
<ul style="list-style-type: none"> • Reduce consolidation settlement 	<ul style="list-style-type: none"> • Precompression • Jet grouting • Compaction grouting • Stone columns • Deep soil mixing • Electro-osmosis
<ul style="list-style-type: none"> • Increase rate of consolidation settlement 	<ul style="list-style-type: none"> • Vertical drains, with or without surcharge fills • Sand and gravel compaction piles
<ul style="list-style-type: none"> • Improve stability of slopes 	<ul style="list-style-type: none"> • Buttress fills • Gravel drains • Penetration grouting • Compaction grouting • Jet grouting • Deep soil mixing • Soil nailing • Sand and gravel compaction piles
<ul style="list-style-type: none"> • Improve seepage barriers 	<ul style="list-style-type: none"> • Jet grouting • Deep soil mixing • Penetration grouting • Slurry trenches
<ul style="list-style-type: none"> • Strengthen and/or seal interfaces between embankments/abutments/foundations 	<ul style="list-style-type: none"> • Penetration grouting • Jet grouting

Table 3 (cont.) - Potentially Applicable Ground Improvement Methods for Civil Works Structures

Purpose	Method
<ul style="list-style-type: none"> • Seal leaking conduits and/or reduce piping along conduits 	<ul style="list-style-type: none"> • Penetration grouting • Compaction grouting
<ul style="list-style-type: none"> • Reduce leakage through joints or cracks 	<ul style="list-style-type: none"> • Penetration grouting
<ul style="list-style-type: none"> • Increase erosion resistance 	<ul style="list-style-type: none"> • Roller compacted concrete • Biotechnical stabilization • Admixture stabilization
<ul style="list-style-type: none"> • Stabilize dispersive clays 	<ul style="list-style-type: none"> • Add lime or cement during construction • Protective filters • For existing dams, add lime at upstream face to be conveyed into the dam by flowing water
<ul style="list-style-type: none"> • Stabilize expansive soils 	<ul style="list-style-type: none"> • Lime treatment • Soil replacement • Cement treatment • Keep water out
<ul style="list-style-type: none"> • Stabilize collapsing soils 	<ul style="list-style-type: none"> • Prewetting/hydroblasting • Vibrocompaction • Deep dynamic compaction • Grouting

Table 4 – Summary of Ground Improvement Methods for Remediation of Large, Open, Undeveloped Sites

Method	Soil Type	Effective Depth	Typical Layout & Spacing	Attainable Improvement	Advantages	Limitations	Prior Experience
Deep Dynamic Compaction (DDC)	Saturated sands and silty sands; partly saturated sands	Up to 10 m	Square pattern, 2 to 6 m spacing	$D_r = 80\%$ $(N_1)_{60} = 25$ $q_{c1} = 10-15$ MPa	Low cost, Simple	Limited effective depth, Clearance required, Vibrations	Extensive
Vibrocompaction, Vibrorod	Sands, silty sands, gravelly sands < 20% fines	30 m	Square or triangular pattern, 1.5 to 3 m spacing	$D_r = 80+\%$ $(N_1)_{60} = 25$ $q_{c1} = 10-15$ MPa	Proven effectiveness, Uniformity with depth	Special equipment, Unsuited in cobbles and boulders	Very extensive
Stone Columns (Vibroreplacement)	Soft, silty or clayey sands, silts, clayey silts	30 m	Square or triangular pattern, 1.5 to 3 m center to center column spacing	$(N_1)_{60} = 20$ $q_{c1} = 10-12$ MPa	Proven effectiveness, Drainage, Reinforcement, Uniformity with depth, Bottom feed dry process puts fill where needed	Special equipment, Can't use in soil with cobbles and boulders	Very extensive
Sand and Gravel Compaction Piles	Can be used in most soil types	20 m	Square or triangular pattern, 1 to 3 m center to center spacing	Up to $(N_1)_{60} = 25-30$, $q_{c1} = 10-15$ MPa, depending on soil type	Proven effectiveness, Reinforcement, Drainage, Uniformity with depth	Special equipment, Slow, Expensive	Very extensive
Gravel Drains	Sands, silty sands	20 m (?)	Spacing selected to minimize excess pore pressure ratio	Reduce pore pressure buildup, Intercept pore pressure plumes	Inexpensive, Does not require treatment of full area	May require very close spacing, Settlement not prevented	Some applications for interception of pore pressure plumes

Table 4 (cont.) – Summary of Ground Improvement Methods for Remediation of Large, Open, Undeveloped Sites

Method	Soil Type	Effective Depth	Typical Layout & Spacing	Attainable Improvement	Advantages	Limitations	Prior Experience
Explosive Compaction	Saturated sands, silty sands	Unlimited	Square or triangular pattern, 3 to 8 m spacing in developed areas, 8 to 15 m spacing in remote areas, vertical spacing varies with size of charge	$D_r = 75\%$ $(N_1)_{60} = 20-25$ $q_{c1} = 10-12$ MPa	Inexpensive, Simple technology	Vibrations, Psychological barriers	Extensive use; no EQ yet at improved sites
Buttress Fills (below and above ground)	All soil types	N/A	N/A	Site specific, Increases stability, Increased liquefaction potential, Barriers against lateral spreading	Lower cost, Protection of existing embankments and large unimproved sites	Space needed for above ground buttresses, Liquefaction settlement in retained areas	Seismic retrofit of embankment dams and retention of liquefiable sites
Deep Soil Mixing	Most soil types	20 m	Select treatment pattern depending on application	Depends on size, strength and configuration of DSM elements	Positive ground reinforcement, Grid pattern contains liquefiable soil, High strength	Requires special equipment, Brittle elements	Excellent performance in 1995 Kobe EQ

Table 4 (cont.) – Summary of Ground Improvement Methods for Remediation of Large, Open, Undeveloped Sites

Method	Soil Type	Effective Depth	Typical Layout & Spacing	Attainable Improvement	Advantages	Limitations	Prior Experience
Prefabricated Vertical (PV) Drains (Wick Drains)	Moderately to highly compressible soils; clayey sands, silts, clays and their mixtures	Up to 65 m; over 20 m depth requires crane to install	Square or triangular pattern, spacing 1.5 to 6 m	Depends on final consolidation pressure	Proven effectiveness, Low cost, Simple	Unsuitable if obstructions exist above compressible layer	Very extensive
Prewetting	Collapsing soils such as loess, debris flows	Essentially unlimited, but not effective at shallow depths	N/A	When used alone, can reduce settlement due to existing overburden, When used with other methods, can reduce settlement due to additional load	Low cost, Simple	Usually not effective at shallow depths, Works best in combination with dynamic compaction, preloading, or explosive compaction	Extensive
Replacement	All soils	A few m	N/A	High density fills to cemented materials	Can design to desired improvement level	Expensive, Might require temporary support of existing structures	Very limited
Admixture Stabilization	Cement – sands and silty sands Lime – clays and clayey sands	A few m	N/A	High density fills to cemented materials	Can design to desired improvement level	Results depend on degree of mixing & compaction achieved in field	Extensive

Table 4 (cont.) – Summary of Ground Improvement Methods for Remediation of Large, Open, Undeveloped Sites

Method	Soil Type	Effective Depth	Typical Lay-out & Spacing	Attainable Improvement	Advantages	Limitations	Prior Experience
Roller Compacted Concrete	Sands and gravels, up to 15% fines	N/A	N/A	Cemented material	Can design steep slopes (0.7H:1V). Can place using conventional earth moving equipment	Bonding between lifts important, therefore, have to place quickly, keep lift surfaces clean	More than 25 new dams > 50 feet high in U.S. since early 1980's
Biotechnical Stabilization and Soil Bio-engineering	All soils	A few m	Depends on application	Stabilize slopes, Prevent erosion	Cost effective, attractive treatment for shallow mass movement and erosion, Environmentally compatible, Blends in with natural surroundings, Can allow native plants to overtake treated area by succession	Keeping vegetation alive until established, Difficult to establish vegetation on slopes steeper than 1.5H:1V, Difficult to quantify reinforcement contribution of root systems	Extensive

Table 5 – Summary of Ground Improvement Methods for Remediation of Constrained and/or Developed Sites

Method	Soil Type	Effective Depth	Typical Layout & Spacing	Attainable Improvement	Advantages	Limitations	Prior Experience
Penetration Grouting	Sands and coarser materials	Unlimited	Triangular pattern, 1 to 2.5 m spacing	Void filling and solidification	No excess pore pressure or liquefaction, Can localize treatment area	High cost, Fines prevent use in many soils	Extensive
Compaction Grouting	Any rapidly consolidating, compressible soil including loose sands	Unlimited	Square or triangular pattern, 1 to 4.5 m spacing, with 1.5 to 2 m typical	Up to $D_r = 80\%+$ $(N_1)_{60} = 25$ $q_{c1} = 10-15$ MPa (Soil type dependent)	Controllable treatment zone, Useful in soils with fines	High cost, Post-treatment loss of prestress	Limited
Jet Grouting	Any soil; more difficult in highly plastic clays	Unlimited	Depends on application	Solidification of the ground – depends on size, strength and configuration of jetted elements	Controllable treatment zone, Useful in soils with fines, Slant drilling beneath structures	High cost	Limited; to date, in U.S. most applications have been for underpinning
Explosive Compaction	Sands, silty sands	Unlimited	Square or triangular pattern, 3 to 8 m spacing in developed areas, 8 to 15 m spacing in remote areas, vertical spacing varies with size of charge	$D_r = 75\%$ $(N_1)_{60} = 20-25$ $q_{c1} = 10-12$ MPa	Inexpensive, Simple technology, Can localize treatment zone, Slant drilling possible	Vibrations, Psychological barriers, Settlement	Limited use in U.S.

Table 5 (cont.) - Summary of Ground Improvement Methods for Remediation of Constrained and/or Developed Sites

Method	Soil Type	Effective Depth	Typical Lay-out & Spacing	Attainable Improvement	Advantages	Limitations	Prior Experience
Mini-Piles	Any drillable soil	Several m beneath existing structures	Depends on application	Transfers loads through weak soil	Structural support	Expensive, Potential settlement around structure	Deep foundations have performed well
Soil Nailing	Any drillable soil, except very soft clays	Unlimited	1 grouted nail per 1 to 5 m ² , 1 driven nail per 0.25 m ²	Stabilize cut slopes and excavations	Flexible system, Can tolerate large movements, Highly resistant to dynamic loading, Can install with small, mobile equipment, Reinforcement is redundant, so weak nail will not cause catastrophic failure	Excavation or cut slope must remain stable until nails are installed, Difficult to construct reliable drainage systems, May require underground easement on adjacent property	Used mainly in Europe until recently
Replacement	All soils	A few m	N/A	High density fills to cemented materials	Can design to desired improvement level	Expensive, Might require temporary support of existing structures	Very limited
Roller Compacted Concrete	Sands and gravels, up to 15% fines	N/A	N/A	Cemented material	Can design steep slopes (0.7H:1V), Can place using conventional earthmoving equipment	Bonding between lifts important, therefore, have to place quickly, keep lift surfaces clean	As of 1993, 30 projects have been modified using RCC

Table 6 - Summary of Approximate Costs for Various Ground Improvement Methods

Method	Relative Cost	Cost per m (\$)	Cost per m ² ground sur-face/wall face (\$)	Cost per m ³ treated ground (\$)	Reference	Comments
Deep Dynamic Compaction	Low	--	8 to 32	~5	FHWA (1998)	
Vibrocompaction, Vibrorod	Low to moderate	No backfill (B/F) - 15 Granular B/F - 25	--	1 to 4	FHWA (1998)	Plus mobilization of \$15,000/rig
Stone Columns (Vibro-replacement)	Moderate	Starts at 45 to 60 if suitable B/F readily available	--	--	FHWA (1998)	Plus mobilization of \$15,000/rig
Gravel Drains	Moderate	11 to 22	--	--	Ledbetter (1985)	
Explosive Compaction	Low	--	--	2 to 4	Adalier (1996)	
Compaction Grouting	Low to moderate	--	--	5 to 50	FHWA (1998)	Plus mobilization, pipe installation costs
Particulate Grouting (Permeation)	Moderate	--	--	3 to 30	Adalier (1996)	

Table 6 (cont.) – Summary of Approximate Costs for Various Ground Improvement Methods

Method	Relative Cost	Cost per m (\$)	Cost per m ² ground surface/wall face (\$)	Cost per m ³ treated ground (\$)	Reference	Comments
Chemical Grouting (Permeation)	High	--	--	150 to 400	Hayward Baker (1996)	If > 700 m ³ will be treated with sodium silicate grout, assume \$195/m ³ plus mobilization (\$10-50K) plus installation of grout pipes (\$65/m) (FHWA, 1998)
Jet Grouting	High to very high	Seepage control: 30 to 200 Underpinning, excavation support: 95 to 650	--	--	FHWA (1998)	Columns approximately 1 m diameter; if headroom is limited, assume high end of range
Soil Nailing	Moderate to high	--	Permanent: 165 to 775 Temporary: 160 to 400	--	FHWA (1998)	Permanent cost depends on type of facing
Deep Soil Mixing	High to very high	--	--	100 to 150	FHWA (1998)	Plus mobilization of \$100,000
Roller Compacted Concrete	--	--	--	New construction: 25 to 75 Overtopping protection: 65 to 130	Portland Cement Association (1992, 1997)	

Table 6 (cont.) – Summary of Approximate Costs for Various Ground Improvement Methods

Method	Relative Cost	Cost per m (\$)	Cost per m ² ground sur-face/wall face (\$)	Cost per m ³ treated ground (\$)	Reference	Comments
Prefabricated Vertical (PV) Drains (Wick Drains)	Low	Drains only Small projects (3 - 10,000 LM): 2.25 to 4.00 Medium projects (10,000 - 50,000 LM): 1.60 to 2.50 Large projects (> 50,000 LM): 1.20 to 2.00	--	--	FHWA (1998)	Plus mobilization of \$7,000 to \$15,000 Also need to consider costs of drainage blanket, surcharge, obstructions or dense soils, design, installation, and monitoring
Biotechnical Stabilization	Depends on application	Vegetated geogrid: 40 to 100	Live slope grating: 275 to 550 (of front face)	--	ASCE (1997)	
Replacement	--	--	--	10 to 20	Hayward Baker (1996)	

CHAPTER 4

HOW IS GROUND IMPROVEMENT DESIGNED?

Design Considerations and Parameters

After it is determined that ground improvement is required, a treatment method must be selected and an improvement program designed. The project design and performance requirements will dictate some of the design parameters, including the required stability and the allowable deformation of treated ground under static and dynamic loading. The subsurface conditions will set other design criteria, such as the suitability of different ground improvement methods and the required depth and areal extent of treatment. Collectively, these factors will determine the level of improvement required to assure satisfactory performance. Site constraints will also play a role in design, as will the construction schedule and the construction budget. Finally, the availability of experienced or specialty contractors in the area will be a design consideration.

Design and Performance Requirements. Different structures will have different performance requirements; for example, a linear structure like a bridge may have different displacement limitations than a settlement-sensitive isolated building. In determining the level of improvement required, the following questions should be considered:

1. Is the improvement for an existing facility or a proposed facility?
2. How much settlement is the structure able to tolerate under normal service conditions?
How much movement or settlement is tolerable during a natural hazard such as an earthquake or a flood?
3. Is the facility a critical or a non-critical structure? A critical structure could be a navigation lock where closure of the facility could result in serious economic losses or a dam where failure could cause significant loss of life or property. A non-critical facility could be a warehouse, where significant damage would be inconvenient, but not critical or life-threatening.

1 Feb 99

4. Can the facility tolerate the anticipated seepage or would it cause economic losses or danger of erosion and piping?
5. How much resistance to liquefaction is needed? Should a "two-level" mitigation strategy be used whereby sufficient remediation is proposed to: (1) avoid significant damage and loss of serviceability under the design earthquake and (2) avoid catastrophic failure, while allowing repairable damage, in the maximum credible earthquake (Mitchell et al., 1998)?

Site constraints. Site constraint considerations can be addressed by the following questions:

1. How large is the area that needs to be treated?
2. Is the site large or small? Is it open or constrained by structures or utilities?
3. Are there nearby buildings that are sensitive to vibrations?
4. Will property easements from adjacent sites be necessary to complete the ground improvement, e.g. for soil nailing or micro-piles?

Subsurface conditions. Answers to the following questions will aid in selecting suitable methods and determining the size and depth of the treatment zone:

1. What type of soil needs to be improved? What methods are appropriate for improving it?
2. At what depth and how thick is the layer that needs to be treated? How far outside the footprint of the structure does the layer need to be treated?
3. Is the layer saturated? At what depth is the ground water table?
4. Is there more than one layer that needs to be treated, such as a loose fill overlying a soft clay layer? Is a different method needed for each layer that needs to be treated, or can one method treat all the layers that need to be improved?

Scheduling. Construction scheduling can restrict the potentially applicable ground improvement methods. Certain methods produce immediate improvement (e.g. vibroflotation), while others require time (e.g. wick drains). Other methods produce an initial improvement and then a continuing strength gain with time (e.g. explosive compaction, methods involving ce-

mentation reactions). The improvement method selected must be compatible with the time available for improvement.

Budget and availability of contractor. The selection of a ground improvement method will also depend on the construction budget and the funds available for improvement. If plenty of free fill is available, use of a buttress may be a cost effective improvement technique. At premium urban sites, the cost of more expensive improvement methods may be relatively small when compared to real estate costs. If a specialty contractor is located near the site, selection of a proprietary ground improvement method may be cost effective because of a relatively small mobilization charge.

Design Procedures

With the aid of answers to the foregoing questions, the following steps can be followed to design the ground improvement program:

1. Select potential improvement methods.
2. Develop and evaluate remedial design concepts.
3. Choose methods for further evaluation.
4. Perform final design for one or more of the preliminary designs.
5. Compare final designs and select the best one.
6. Field test for verification of effectiveness and development of construction procedures.
7. Develop specifications and QA/QC programs.

These steps are discussed in more detail below.

Select potential improvement methods. A preliminary screening and evaluation of methods can be made using Tables 2, 3, and 4 in Chapter 3. A list of potentially applicable methods for a particular ground improvement purpose can be developed using Table 2. The list can be refined by using Tables 3 and 4 to select methods that should be suitable in light of the particular site constraints.

Develop and evaluate remedial design concepts. Preliminary designs can be developed for each improvement method selected in the previous step. Tentative layouts and treatment points for each method can be developed using Tables 3 and 4, and/or from propriety or empirical guidelines and design programs offered by specialty contractors. The tentative size and location of the treatment zone can be established using empirical guidelines, which are discussed below in "Design Recommendations." If the design includes retrofitting a structure, the improvements to existing foundation elements should be determined, and/or new foundation elements should be designed.

Analyses should be performed for each preliminary design to determine if the treated zone will be improved sufficiently to meet the design and performance requirements. For non-critical structures, the analyses may be as simple as confirming that the factors of safety are adequate when computed using the anticipated properties for the improved soil. However, detailed ground deformation and foundation loading analyses may be required for critical or complex structures. These analyses require information on the geometry and properties of the treatment zone for each improvement method. Preliminary cost estimates can also be developed using Table 5 to aid in selecting methods for further evaluation.

Choose methods for further evaluation. The preliminary designs can be compared to determine which methods appear to be the best alternatives for the particular site. Further analysis can be done for each of these options.

Develop tentative final designs for the selected preliminary designs. Detailed design and cost estimates are developed for one or more of the selected preliminary designs. The location, size, shape and required properties of treatment zones or foundation improvements are determined. This stage includes determining locations and depths of treatment and developing construction details for the foundation improvements. Methods for evaluating the post-treatment results in the field are developed. Analyses are performed for the final designs to confirm that the anticipated performance of the facility will be satisfactory.

Compare final designs and select the best one. The final design plans and cost estimates are analyzed to determine the best scheme for improving the site or facility. The final selection is based both on cost and on the expected performance of the facility after improvement, constructability, the time available for construction, and the availability of contractors to perform the work.

Field testing for design verification and development of construction procedures. For most projects, a field testing program should be developed and executed to verify that the required improvement can be obtained using the proposed method. The design can be adjusted during this phase to optimize the spacing of the treatment locations so the required improvement can be obtained in an efficient manner.

Develop specifications and QA/QC programs. Construction specifications and QA/QC programs will be required for the design that will be implemented. The specifications can be either procedural or end result, however, the QA/QC program should be consistent with the type of construction specifications. These issues are discussed in more detail in the following chapter.

Design Issues

There are certain design problems that are specific to certain ground improvement methods, while others are general and apply to most methods. In general, ground improvement designs are based on empirical guidelines rather than rigorous design procedures. Some methods are proprietary and can only be designed and implemented by specialty contractors. Most require extensive field testing programs before the design can be finalized. Some are still being developed, so it may sometimes be difficult to write unambiguous and enforceable specifications and QA/QC programs.

Some of the design problems specific to different methods or applications are summarized below.

Prefabricated Vertical (PV) Drains (Wick Drains): According to ASCE (1997), PV drains have performed well in many past projects mainly because they are designed conservatively. When PV drains are designed to function near their maximum capacity, the installations will need to be monitored carefully. The drain capacity could be the limiting factor in cases where PV drains are designed for sites where there are deep compressible layers with surcharge loading. Before using PV drains below a depth of 45 m, a specialist should be consulted. PV drains have been used for mitigation of liquefaction risk in a few cases; however, little research has been performed to quantify the extent of improvement that can be obtained in this application.

Soil Nailing: There have been inconsistencies in the design methods for soil nailed walls (Xanthakos et al., 1994). It is recommended that the Manual for Design and Construction Monitoring of Soil Nail Walls (FHWA, 1996b) be used, as it synthesizes current design and construction methods into a comprehensive and consistent guideline procedure. Worked design examples are included in the manual. A companion manual for construction monitoring is also available (FHWA, 1996c).

Micro-piles: When conventional piles are closely spaced, the nominal capacity of each pile is reduced to account for a group effect. In contrast, closely spaced pin piles have been reported to have higher capacity than widely spaced piles, particularly when the piles are reticulated, i.e. intertwined (Xanthakos et al., 1994). This positive group effect is not routinely exploited in design. However, there is also no reduction to account for a group effect as is done in conventional pile design.

Stone columns/Gravel drains: When gravel drains are used for dissipation of excess pore pressure, it is difficult to predict the permeability that can be obtained. During installation, there is mixing between the stone and the in-situ soil, so the final drain contains a mixture of soil and stone. Different studies have estimated that the in-situ soil comprises about 20% of the completed stone column (Boulanger et al., 1998). It is also difficult to measure the permeability properties of stone columns in the field.

Seismic applications: When designing ground improvement to reduce the risk of liquefaction or lateral spreading, the primary concern is limiting the deformations of a supported structure to acceptable levels. In order to limit deformations, it is first necessary to have adequate ground strength to resist overall failure of the ground and structure.

There are numerous factors which influence the stability and deformation of improved ground zones and structures during and after an earthquake, as described by Mitchell et al. (1998). The size, location and type of treated zone influences the behavior of the improved ground and the supported structure. Migration of pore pressure from an untreated zone into an improved zone can reduce the strength in the improved zone. Improved ground may amplify the earthquake motion, resulting in more severe loading on a supported structure. The maximum inertial forces that act on the improved ground and the structure may act at different times, causing a complex soil-structure interaction problem. In cases where improved ground is located in sloping areas, there may be additional forces imposed on the improved ground zone if the surrounding unimproved ground undergoes lateral spreading. Some of these factors can be incorporated into complex analytical models, but most of them have not been incorporated into simplified methods of analyses.

Design Recommendations

Depth of treatment: For liquefaction mitigation, the depth of treatment generally should extend to the bottom of the layer that requires improvement, particularly for large or heavily-loaded structures. For lightly-loaded structures, it may not be necessary to treat the entire liquefiable layer, however, design procedures for an improved "crust" over liquefiable soils are not well established. For free-field conditions or lightly-loaded structures, Ishihara (1985) presents correlations between the minimum thickness of a non-liquefiable surface layer, the maximum thickness of an underlying liquefiable layer and surface manifestations of liquefaction. For several sites in Japan subjected to maximum accelerations of about 0.2g, liquefaction damage was observed when the crust thickness was less than 3 m. For sites where the crust thickness was less than 3 m, more damage was observed if the liquefiable layer was

greater than 3 m in thickness. Youd and Garris (1995) performed a similar study on additional sites and concluded that Isihara's 1985 criteria were valid for sites that are not susceptible to lateral spreading or ground oscillation. Naesgaard et al. (1998) developed a simplified procedure for determining the response of a foundation placed on an existing cohesive crust if the underlying layer liquifies. This method was mentioned in Chapter 2.

For "conventional" ground improvement applications, the depth of treatment should extend either to the depth of influence of the structure or to the bottom of the layer requiring improvement. The approximate 2:1 load spread method can be used for a first estimate of the depth of influence of the structure. The load spread method assumes that the stress from a foundation spreads out beneath the structure on lines with a slope of 2 vertical to 1 horizontal. The average stress increase at a depth z , assuming rectangular foundation dimensions L and B and an average pressure of q , can be calculated by the following equation:

$$\Delta\sigma_z = \frac{qLB}{(L+z)(B+z)}$$

If more accuracy is needed, a Boussinesq or Westergaard analysis can be used.

Areal extent of treatment: For liquefaction protection, the treatment zone should generally extend outside the perimeter of the structure at least a distance equal to the thickness of the treated layer. The performance of sites where space constraints prevented implementation of this recommendation are discussed in Chapter 6. For "conventional" applications, the treatment zone should extend outside the perimeter at least a distance equal to half the thickness of the treated layer. This guideline accounts for the stress increase beneath a foundation based on the approximate 2:1 load spread method.

Seismic remediation: Liquefaction potential assessment curves (Seed et al., 1984, NCEER, 1997) appear useful for design of ground improvement by densification in seismic areas. The effects of ground improvement on liquefaction potential for five improved sites that were shaken in the 1989 Loma Prieta or the 1995 Hyogo-ken Nambu (Kobe) earthquakes are shown in Figure 44. The liquefaction-no liquefaction boundary curve shown is the consensus

curve adopted in NCEER (1997) for clean sand and a magnitude 7.5 earthquake. All data points have been corrected for fines content, overburden pressure and earthquake magnitude according to the NCEER (1997) recommendations to give the equivalent $(N_1)_{60cs}$ and cyclic stress ratio (CSR) values shown. The closed and open symbols on the figure indicate pre- and post-treatment SPT $(N_1)_{60cs}$ values, respectively. The percentage of fines, if known, is shown on Figure 44 for each facility. If the percentage of fines was not known, the $(N_1)_{60}$ value was assumed to equal $(N_1)_{60cs}$. For the most part, the liquefiable layers were improved from the "liquefaction" (left) to the "no liquefaction" (right) side of the liquefaction potential curve. With the exception of the Kobe Port Island Warehouse, little or no deformation was reported at the sites after shaking. From these data, it appears that liquefaction effects will be minor if the supporting ground is improved by densification to the "no liquefaction" side of liquefaction potential curves for CSR values less than about 0.3, and ground deformations will be reduced significantly for higher levels of shaking. For design using the liquefaction potential curve, the CSR and the percentage of fines, the minimum required $(N_1)_{60cs}$ can be determined throughout the potentially liquefiable layer.

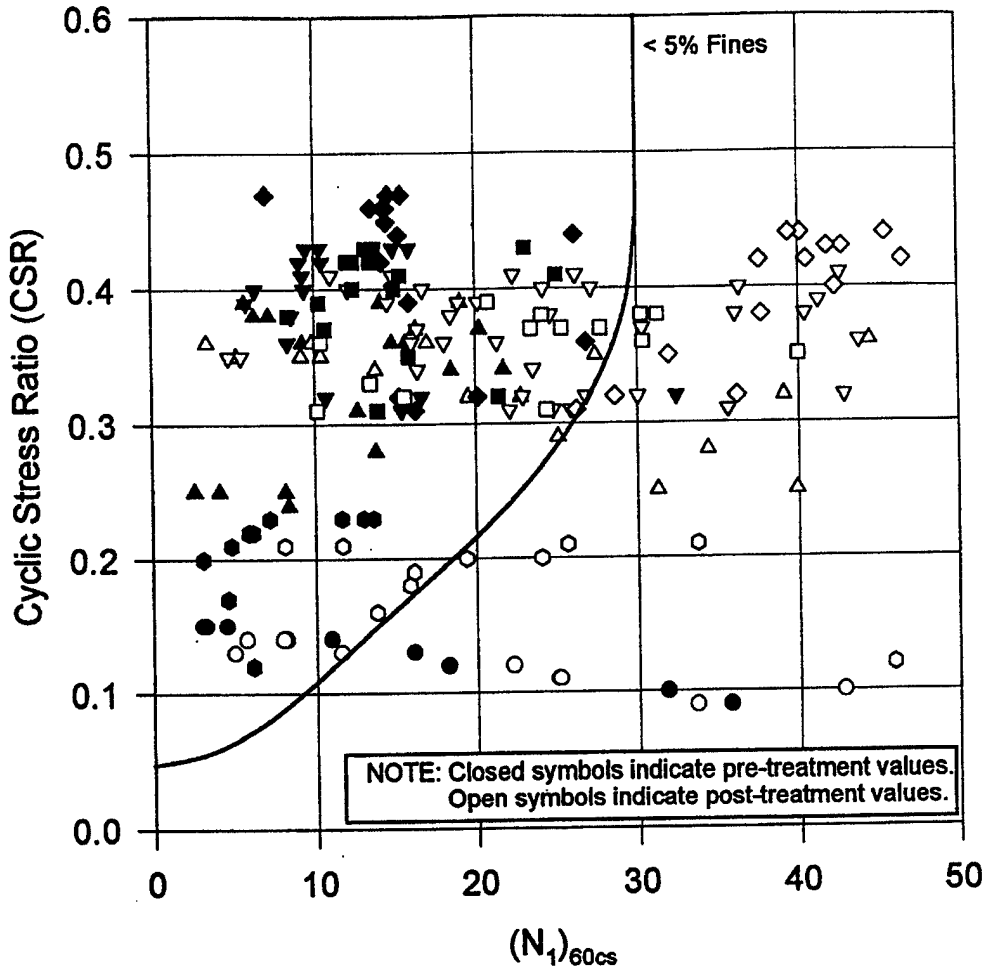

- Building 450 (LP), <10% fines, assume $(N_1)_{60} = (N_1)_{60cs}$
- ▲ Adult Detention Facility (LP), assume $(N_1)_{60} = (N_1)_{60cs}$
- ▼ Amusement Park (Kobe), <10% fines, assume $(N_1)_{60} = (N_1)_{60cs}$
- ◆ Warehouse Facility (Kobe), 15-30% fines, EERC (1995) data, assume 15% fines for correction to $(N_1)_{60cs}$
- Warehouse Facility (Kobe), 10% fines, Ishihara et al. (1998) data, assume 10% fines for correction to $(N_1)_{60cs}$
- "Super Dike" Test Area (Kobe), 5-35% fines, assume $(N_1)_{60} = (N_1)_{60cs}$

Notes: 1. The CSR values were adjusted to equivalent CSR values for the M=7.5 base curve using the magnitude scaling factor proposed by Idriss (1997).
 2. $(N_1)_{60}$ values for were corrected to clean sand $(N_1)_{60cs}$ values based on NCEER (1997).

Figure 44. Effect of ground improvement on liquefaction potential for sites that were shaken in the 1989 Loma Prieta and 1995 Hyogo-ken Nambu (Kobe) earthquakes.

CHAPTER 5

WHAT ARE QA/QC REQUIREMENTS FOR IMPROVED GROUND?

Verifying that the level of improvement required has been obtained is a difficult but extremely important aspect of ground improvement. Quality assurance and quality control consist of two phases: observation during construction and geotechnical verification testing after construction is completed. During construction, observations should be made and recorded at each improvement location, including ground surface movements, the volume of backfill material used, grout take, and the amount of energy or pressure expended. After construction, in-situ methods such as SPT, CPT and/or shear wave velocity testing can be performed to verify that the level of improvement required is achieved. Laboratory testing can also be used to evaluate some types of improvement.

Construction Observations

Construction observations provide an initial indication of the effectiveness of the method. While they cannot be used as the sole indicator that ground improvement has been successful, they give a general idea of where the treatment has succeeded or failed. In-situ testing can then be performed in areas where the observations indicate the minimum degree of improvement achieved. Such selective testing will give conservative results regarding the overall level of improvement achieved.

Different types of ground improvement require different types of construction observations and sampling. Some of the necessary observations for different methods are described below.

Admixture-Stabilized Soils. During stabilization of soils with admixtures, the most important observations are the amount of admixture and water mixed into the soil, the amount of mixing performed, and the amount of compactive effort used on the fill. The moisture content and

density of the fill can be determined in the field. The curing time and conditions should also be recorded. Samples should be taken for laboratory testing.

Roller Compacted Concrete. One of the most important factors in satisfactory performance of RCC is bonding between layers. Therefore, it is important to observe that bedrock is cleaned thoroughly prior to placement of the RCC or bedding concrete. Bonding between successive lifts of RCC depends on the time between placement of successive lifts, temperature and humidity. If lifts are not placed continuously, "cold joints" consisting of bedding concrete may be required. The time between mixing and placement of the RCC, as well as the time between placement of successive lifts should be recorded. In addition, the weather conditions, lift thickness, degree of compactive effort placed on the RCC, wet density and water content of the RCC, and location of cold joints should be observed and noted. The lift surface and haul road should be kept clean to prevent the inclusion of soil and other debris in the RCC. Samples should be taken for laboratory testing.

Deep Dynamic Compaction. Observations during deep dynamic compaction include the height of the drop, the location of the drop points, the number of drops at each location, and the crater depth for each drop. The type of backfill and degree of compactive effort used in the crater should be noted. Based on the average surface settlement and the volume of backfill added, the average change in relative density in the improved zone can be calculated. If necessary, vibrations should be measured in nearby structures.

Vibro Methods. For vibro methods, it is important to record the location of the treatment points, the volume and depth distribution of material used to backfill the probe holes, and the vibroflot energy and time spent densifying the backfill at each location and depth. The settlement of the ground surface should be monitored. These observations give a general indication of the overall effectiveness of the treatment and the level of densification achieved. As with DDC, the average change in relative density can be calculated based on surface settlement and the amount of backfill added.

Explosive Compaction. When explosive compaction is used, the location of the boreholes and the depths of the charges should be recorded. After blasting, the surface settlements should be noted. If water erupts from the boreholes after blasting, it should be noted. If necessary, vibrations should be measured in nearby structures.

Penetration and Compaction Grouting. For grouting, the following observations should be made: the location of the injection points; the volume and location of each type of grout injected; depth, pressure, duration of grout injection; and, ground surface elevations before, during, after construction to check for settlement or heave of the ground or structure. Grout mix samples should be taken for strength testing. These observations provide information on where the grout is going in the soil mass and the overall effectiveness of the treatment.

Jet Grouting. Most jet grouting projects require test sections prior to construction to determine the geometry and quality of treated material that can be obtained. During construction, it is important to note if the grouting parameters and materials are consistent with the approved test section. As discussed in Chapter 3, the ability to erode the soil with the jets is an important factor in successful jet grouting. There should be a continuous flow of spoils to the ground surface during jetting. If there is no spoil return, it is possible that hydrofracturing is occurring. The rate of rotation and removal of the grout pipe and the rate of material consumption should be monitored. Preliminary assessments of the geometry of the treated ground can be made by measuring the unit weight of the waste return, however, the best methods for assessing the geometry are excavation or coring (ASCE, 1997). Wet grab samples should be taken for strength and permeability testing. If piezometers are installed for later hydraulic conductivity measurements, the construction details of the piezometers should be recorded.

Micro-piles, Soil Nailing, and Deep Soil Mixing. During construction, the material quantities used in construction should be compared to the design quantities. If the material quantities used are much less than design quantities, it is possible that the ground has "squeezed" into the hole and the pile or wall integrity could be compromised. In addition, the lengths of the

piles or nails and the depths of the deep-mixed elements should be recorded. The drilling time and difficulty, as well as the type and quantity of spoils should be observed for each element.

PV Drains. Prior to installation of the PV drains, a gravel drainage blanket is typically placed. The thickness of the drainage layer and the type of gravel used should be recorded. The installation of monitoring devices such as piezometers, settlement platforms and gauges, and/or inclinometers should be observed. Details such as type of instrument, location, and elevation should be recorded. During drain installation, the length and location of each drain should be recorded.

Biotechnical Stabilization and Soil Bioengineering. The USDA Soil Conservation Service has a chapter in its Engineering Fieldbook (USDA, 1992) that discusses the use of biotechnical stabilization and soil engineering for slope protection and erosion control. The chapter contains guidelines and directions for use of biotechnical stabilization. Field observations for planting should include the type and quantity of seed or vegetation being planted, the location of the materials being planted, and soil, watering and weather conditions. For structural elements, the location and type of elements should be recorded, as well as fill placement and compaction procedures behind the structural elements.

Verification Testing

General. The most common methods used for in-situ verification of ground improvement are SPT and CPT testing. Other methods that may be used include Becker penetration testing (BPT) for soils with high gravel or cobble contents, shear wave velocity testing and vane shear testing. The tests are usually performed midway between treatment locations to determine the properties at the locations that are expected to have the smallest degree of improvement. When determining post-treatment properties, it is preferable to use the same test that was used to determine pre-treatment properties. On some projects, the lack of comprehensive data on pre-treatment conditions has made it difficult to evaluate the properties of the treated

ground. It is also important to consider the time after treatment at which the tests will be performed, since properties of improved ground often continue to show an increase over time.

Shear wave velocity testing can be used to verify the overall improvement obtained from compaction grouting or vibro methods; however, the results can be difficult to interpret due to the heterogeneity of the improved ground. Load testing can be used to verify the capacity of stone columns and axially- or laterally-loaded micro-piles. Inclometers or movement gauges can be used to monitor the performance of reticulated micro-pile installations or soil nailed walls. Coring and excavation are the best techniques for verification of the geometry and quality of jet grouting and deep soil mixing construction.

Liquefaction Resistance. The properties of the improved ground can be compared with standard liquefaction potential curves (Figure 44) to assess if the degree of improvement achieved is satisfactory. As discussed in Chapters 4 and 6, use of SPT $(N_1)_{60ca}$ values obtained in improved ground in conjunction with liquefaction potential curves was generally successful in predicting the performance of improved sites subjected to the 1989 Loma Prieta and 1995 Kobe earthquakes.

The use of shear wave velocity testing to verify ground improvement for mitigation of liquefaction risk is becoming more common. While the available data from liquefaction sites is somewhat limited at this time, shear wave velocity testing offers advantages in that it can be performed in soils where it is difficult to perform CPT and SPT testing and there are several techniques available for measurement. The most recent correlations between shear wave velocity and cyclic stress ratio causing liquefaction presented in Andrus and Stokoe (1997) in NCEER (1997) appear to give reliable results. As these correlations have not been tested as extensively as the CPT and SPT correlations, they should be used with caution or be used as a secondary method supporting results obtained using the CPT or SPT.

Hydraulic conductivity. Ground improvement methods are used both for increasing the overall permeability of a soil layer (e.g., gravel drains for liquefiable layers) and decreasing the

permeability of a layer (e.g., seepage cutoff). In both cases, the permeability needs to be evaluated to determine the overall effectiveness of the treatment method.

Pump tests can be used to measure the resultant permeability when jet or penetration grouting is used for seepage control applications. For jet grouting, pump tests using cast-in-place piezometers are preferred because they are non-destructive and have shown reasonable correlations with measurements from wet grab samples (ASCE, 1997). Results from Packer testing have not correlated well with results from wet grab samples. Permeability values determined using cores taken from cemented materials are usually too high owing to the stress release and micro-cracking that accompanies the sampling process.

Pump tests are not recommended to determine the permeability of stone columns for mitigation of liquefaction risk (ASCE, 1997). According to a study conducted by Baez and Martin (1995), field pump tests resulted in permeability values up to two orders of magnitude lower than obtained from empirical correlations and laboratory tests performed on extracted samples. This result could possibly be due to the large difference in permeabilities between the native material and the stone columns and the small column diameter (Baez and Martin, 1995). Therefore, the preferred method is to perform laboratory tests on extracted samples. Empirical correlations can also be used.

Laboratory Testing

Laboratory testing can be used to evaluate the density, strength and stiffness properties of improved soils, especially when admixtures or grouts are used. Grab samples of the stabilized soil can be obtained during construction, cured in the laboratory and tested to give an overall indication of the effectiveness of the treatment. The unconfined compressive strength is a good indicator of properties in admixture-stabilized soils. For example, lime stabilization can be considered satisfactory if the compressive strength increases at least 50 psi after curing 28 days at 73 F. If the soil is reactive and this strength increase is obtained, good results can be

expected with respect to other property values. Strength increases greater than this can be expected if Portland cement is used as the stabilizer.

Laboratory testing is more expensive and difficult if "undisturbed" samples are required after construction. The samples can be difficult to obtain, the effects of disturbance can be significant, and the sampling can destroy the integrity of the installation. Therefore, in-situ verification tests are the preferred method when possible.

CHAPTER 6

WHAT HAS BEEN THE PERFORMANCE OF IMPROVED GROUND?

Many of the ground improvement methods discussed in this manual have been used for many years in "conventional" applications such as improving the bearing capacity, slope stabilization, increasing the rate of consolidation settlement and improving seepage barriers. Experience over the past several decades has shown that the required performance in most conventional applications can be obtained if the appropriate ground improvement method is selected and the design and construction are done well. Xanthakos et al. (1994) present case histories involving many different types of ground improvement, as well as lists of projects where jet grouting, densification techniques, and micro-piles were used successfully. Case histories are also presented in ASCE (1997). An extensive list of jet grouting projects for different applications is presented in ASCE (1997).

A common "trouble spot" with all types of ground improvement is the difficulty in verifying that the desired level of improvement has been attained. Another difficulty with grouting and deep soil mixing occurs in organic soils. Many grouts and additives used for improving soil require a high pH to set. Organic soils are typically somewhat acidic. Therefore, the pH of organic soils may need to be increased if grouting or deep mixing are used.

The use of ground improvement for mitigation of earthquake hazards is relatively new and untested. Therefore, the focus of this chapter is on the performance of improved ground subjected to strong ground motions induced by earthquakes.

While various ground improvement methods have been used at many sites to reduce the settlement and lateral spreading caused by earthquakes, very few of these sites have actually been subjected to strong ground motions. Mitchell et al. (1995) compiled information from more than 30 improved ground sites which experienced large enough earthquake motions that untreated ground liquefied and the effectiveness of various treatment options could be evaluated. The study showed that ground improvement will help prevent liquefaction and ground failure

from occurring and reduce the amount of settlement and lateral displacement that can occur if liquefaction does occur.

The 32 cases studied were located in California and Japan. The California sites were subjected to the 1989 Loma Prieta or the 1994 Northridge earthquake. The Japanese earthquakes included the 1964 Niigata earthquake and the 1995 Hyogoken Nambu (Kobe) earthquake, as well as three lesser known earthquakes (1968 Tokachi-Oki, the 1978 Miyagi-Ken-Oki, the 1993 Kushiro-Oki, and the 1994 Hokkaido-Toho-Oki earthquakes). The magnitudes of these earthquakes ranged from about 6.9 to 8.3. The local ground surface accelerations at the individual sites ranged from as low as 0.1g to as high as 1.0g. Detailed information on the 1995 Hyogoken-Nambu (Kobe) earthquake is presented in two special issues of Soils and Foundations (Japanese Geotechnical Society, January 1996 and September 1998).

The types of soil that were improved consisted primarily of loose to medium-dense sands and sandy silts, many of which were hydraulic sand fills. Prior to treatment, the average $(N_1)_{60}$ values for the layers requiring treatment ranged from 4 to 23 blows per foot. In most cases, the relative densities after ground improvement were greater than 75 percent, with post-treatment $(N_1)_{60}$ values ranging from about 25 to 30 blows per foot.

Types of ground improvement used included vibrocompaction methods, compaction piles, vibroreplacement stone columns, deep dynamic compaction, gravel drains, compaction grouting and chemical grouting. The predominant method of improvement was vibrocompaction by either vibroflotation or vibratorod. Also included in this study were cases where structures were founded on mix-in-place soil-cement columns instead of conventional deep foundations or improved ground. Use of deep soil mixing for structural support and for mitigation of liquefaction risk are relatively new technologies in the United States.

In studying the 32 case histories, Mitchell et al. (1995) found that in general, improved ground experiences much less settlement and lateral displacement than untreated ground. When founded on improved ground, structures and facilities are much less likely to be damaged than

1 Feb 99

are similar facilities founded on untreated ground. At several sites in California, treated ground and facilities built upon it were not damaged due to shaking during the Loma Prieta earthquake, but adjacent untreated ground experienced severe cracking and/or settlement due to liquefaction. It is important to note that most of these sites experienced ground accelerations and durations of shaking that were less than the design values, so the total performance during the design event was not tested. However, at one site subjected to ground accelerations higher than the design acceleration, no damage was observed. At some improved ground sites in Japan, liquefaction and associated settlement and lateral displacement did occur; however, the deformations were significantly less than the deformations experienced at similar sites where the ground was not treated. Facilities at the treated ground sites experienced significantly less damage than similar facilities on untreated ground.

Mitchell et al. (1995) also noted three sites where the lateral extent of treatment outside the perimeter of structures was less than the recommended distance equal to the depth of treatment. As these locations, site constraints prevented this width of treatment. Damage was observed at all three of the sites.

In cases where the layer to be improved is below a loose fill layer, installation of ground improvement measures or deep foundations may cause improvements to the fill itself through densification and prestressing. At several sites in Japan, preloading and sand drains were used for precompression of a soft clay layer overlain by 12 to 20 m of loose hydraulic fill. The process of sand drain installation was found to increase the SPT resistance of the hydraulic fill by about 2 to 3 blows per 0.3 m (Yasuda et al., 1996). Settlement data categorized by ground improvement method is shown in Figure 45. Although the treatments were designed to improve the clay layer rather than the fill, the plot shows that preloading alone, sand drains alone, and sand drains plus preloading were increasingly effective in reducing the earthquake-induced settlements (Mitchell et al., 1995).

Sites where gravel drains were used for mitigation of liquefaction risk generally performed well when subjected to earthquake shaking. Mitchell et al. (1995) report on several cases in

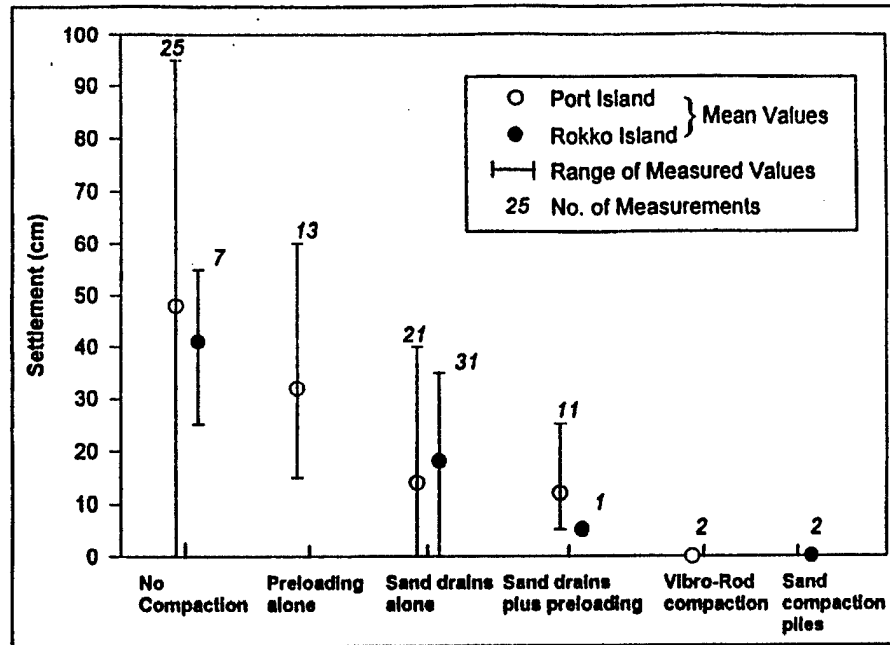

Figure 45. Measured settlements at improved sites due to the 1995 Hyogo-ken Nambu (Kobe) earthquake (after Yasuda et al., 1996).

Japan where gravel drains were used alone or in combination with other improvement techniques. It is not clear if the improvement from gravel drains resulted from dissipation of excess pore pressure or densification of the surrounding ground during installation. Hayden and Baez (1994) surveyed two sites shaken in the 1994 Northridge earthquake where stone columns were used. The structures at both sites were undamaged and there was no evidence of ground distress or liquefaction around the structures.

Mix-in-place soil-cement columns appear to be a viable alternative to deep foundations or ground improvement methods for mitigation of liquefaction risk. Mitchell et al. (1995) reported that eight projects where structures were founded on mix-in-place soil-cement columns performed well in the Kobe earthquake.

When sites are improved to the "no liquefaction" side of liquefaction potential curves, the effects of liquefaction should be relatively minor. At five sites in California and Japan subjected

ETL 1110-1-185

1 Feb 99

to either the Loma Prieta or the Kobe earthquake, enough data were available to determine pre- and post-densification $(N_1)_{60}$ values throughout the soil profile. In these cases, there was a reasonable correlation between the performance of the site and predictions of performance based on standard cyclic stress ratio - $(N_1)_{60}$ relationships (Mitchell et al. 1995).

Felio et al. (1990) performed detailed post-earthquake observations of eight soil nailed walls subjected to shaking during the 1989 Loma Prieta earthquake. The walls ranged in height from 2.7 to 9.8 m and were subjected to maximum ground surface accelerations between 0.01 and 0.47 g. No cracking or other signs of distress were observed in any of the structures. Based on the results of the observations, Felio et al. (1990) concluded that soil nailed walls perform well when subjected to earthquake loading.

REFERENCES

- Adalier, K. (1996). "Mitigation of Earthquake-Induced Liquefaction Hazards." Ph.D. Thesis, Rensselaer Polytechnic Institute, Troy, NY.
- Andrus, R.D. and Stokoe, K.H. (1997). "Liquefaction Resistance Based on Shear Wave Velocity." *Proceedings of the NCEER Workshop on Evaluation of Liquefaction Resistance of Soils*, Technical Report NCEER-97-0022, edited by T.L. Youd and I.M. Idriss, pp. 89-128
- ASCE Soil Improvement and Geosynthetics Committee, Ground Improvement Subcommittee (1997). "Soil Improvement and Geosynthetics Committee Report," *Ground Improvement, Ground Reinforcement and Ground Treatment, Developments 1987-1997*, Geotechnical Special Publication No. 69, Proceedings of the sessions sponsored by the Committee on Soil Improvement and Geosynthetics of the Geo-Institute of ASCE in conjunction with Geo-Logan '97, Logan, Utah, July 1997, V.R. Schaefer, ed., ASCE, pp. 1-371.
- ASTM D 4221-90. "Test Method for Dispersive Characteristics of Clay by Double Hydrometer." *1992 Annual Book of ASTM Standards*, American Society of Testing and Materials, Philadelphia, PA, 1992.
- ASTM D 4647-87. "Test Method for Identification and Classification of Dispersive Clay Soils by the Pinhole Method." *1992 Annual Book of ASTM Standards*, American Society of Testing and Materials, Philadelphia, PA, 1992.
- Baez, J.I. (1995). "A Design Model for the Reduction of Soil Liquefaction by Vibro-Stone Columns." Ph.D. Dissertation, University of Southern California, Los Angeles, CA, 207 p.
- Baez, J.I. and Martin, G.R. (1995). "Permeability and Shear Wave Velocity of Vibro-Replacement Stone Columns." *Soil Improvement for Earthquake Hazard Mitigation*, Geotechnical Special Publication No. 49, ASCE, pp. 66-81.
- Barksdale and Bachus (1983), see FHWA (1983).
- Bartlett, S. F. and Youd, T. L. (1995). "Empirical prediction of liquefaction-induced lateral spread." *Journal of Geotechnical Engineering*, ASCE, 121(4): 316-329.
- Basma, A.A. and Tuncer, E.R. (1992). "Evaluation and Control of Collapsible Soils." *Journal of Geotechnical Engineering*, ASCE, 118(10): 1491-1504.
- Baziar, M.H., Dobry, R. and Elgamel, A-W.M. (1995). "Engineering Evaluation of Permanent Ground Deformations Due to Seismically-Induced Liquefaction." *Proceedings of the NCEER Workshop on Evaluation of Liquefaction Resistance of Soils*, Technical Report NCEER-92-0007, National Center for Earthquake Engineering Research, Buffalo, NY.

- Boulanger, R.W. and Hayden, R.F. (1995). "Aspects of Compaction Grouting of Liquefiable Soils." *Journal of Geotechnical Engineering*, ASCE, 121(12): 844-855.
- Boulanger, R.W., Idriss, I.M., Stewart, D.P., Hashash, Y. and Schmidt, B. (1998). "Drainage Capacity of Stone Columns or Gravel Drains for Mitigating Liquefaction." *Geotechnical Earthquake Engineering and Soil Dynamics III, Geotechnical Special Publication No. 75*, Proceedings of a Specialty Conference, Seattle, Washington, ASCE, Volume 1, pp. 678-690.
- Bruce, D.A. (1991). "Recent Progress in American Pinpile Technology." *Grouting, Soil Improvement and Geosynthetics, Geotechnical Special Publication No. 30*, ASCE, Vol. 2, pp. 765-777.
- Burke, G.K. and Welsh, J.P. (1991). "Jet Grout Uses for Soil Improvement." *Geotechnical Engineering Congress, Geotechnical Special Publication No. 27*, ASCE, Vol. 1, pp. 334-345.
- Clemence, S.P. and Finbarr, A.M. (1981). "Design Considerations for Collapsible Soils." *Journal of the Geotechnical Engineering Division*, ASCE 107(GT3): 305-317.
- Committee on the Safety of Existing Dams (1983). *Safety of Existing Dams: Evaluation and Improvement*, National Academy Press, Washington, DC.
- Department of the Army, Office of the Chief of Engineers (1970). *Stability of Earth and Rockfill Dams*, EM 1110-2-1902, Washington DC.
- Department of the Army, Office of the Chief of Engineers (1978). *Design and Construction of Levees*, EM 1110-2-1913, Washington DC.
- Department of the Army, Office of the Chief of Engineers (1983). *Dredging and Dredged Material Disposal*, EM 1110-2-5025, Washington DC.
- Department of the Army, Office of the Chief of Engineers (1984). *Geotechnical Investigations*, EM 1110-1-1804, Washington DC.
- Department of the Army, Office of the Chief of Engineers (1986). *Seepage Analysis and Control for Dams*, EM 1110-2-1901, Washington DC.
- Department of the Army, Office of the Chief of Engineers (1995). *Planning and Design of Navigation Locks*, EM 1110-2-2602, Washington DC.
- Department of the Army, Office of the Chief of Engineers (1996). *Soil Sampling*, EM 1110-1-1906, Washington DC.
- Department of the Army, Office of the Chief of Engineers (1997). *Hydrologic Engineering Requirements for Reservoirs*, EM 1110-2-1420, Washington DC.

Dobry, R., Oweis, I. and Urzua, A. (1976). "Simplified Procedures for Estimating the Fundamental Period of a Soil Profile." *Bulletin of the Seismological Society of America*, 66(4): 1293-1321.

Duncan, J.M., Horz, R.C. and Yang, T.L. (1989). *Shear Strength Correlations for Geotechnical Engineering*, Virginia Tech Department of Civil Engineering, Blacksbur, VA, 100 p.

EERC (1995). "Geotechnical Reconnaissance of the Effects of the January 17, 1995, Hyogoken-Nambu Earthquake Japan." N. Sitar, ed., Earthquake Engineering Research Center, University of California, Berkeley, Report UBC/EERC-95/01, July.

Elias et al. (1998), see FHWA(1998).

Felio, G.Y., Vucetic, M., Hudson, M., Barar, O. and Chapman, R. (1990). "Performance of Soil Nailed Walls During the October 17, 1989 Loma Prieta Earthquake." *Proceedings, Forty-third Canadian Geotechnical Conference*, Quebec, pp. 165-173.

FHWA (1983). *Design and Construction of Stone Columns*. Volume 1, Report No. 1, FHWA/RD 83/026, Federal Highway Administration, Barksdale, R.D. and Bachus, R.C., 210 p.

FHWA (1986a). *Dynamic Compaction for Highway Construction, Volume 1: Design and Construction Guidelines*. U.S. Department of Transportation, Federal Highway Administration, Research, Development and Technology, Report No. FHWA/RD-86/133, Lukas, R.G.

FHWA (1986b). *Geocomposite Drains*. U.S. Department of Transportation, Federal Highway Administration, Research, Development and Technology, Volume 1: Engineering Assessment and Preliminary Guidelines, Report No. FHWA/RD-86/171.

FHWA (1986c). *Prefabricated Vertical Drains*. U.S. Department of Transportation, Federal Highway Administration, Research, Development and Technology Volume 1, Engineering Guidelines. Report No. FHWA/RD-86/168.

FHWA (1996a). *Drilled and Grouted Micropiles: State-of-Practice Review*, Final Report. Publication Nos. FHWA-RD-96-016, FHWA-RD-96-017, FHWA-RD-96-018, FHWA-RD-96-019, 530 p.

FHWA (1996b). *Manual for Design and Construction Monitoring of Soil Nail Walls*. FHWA Demonstration Project 103, Publication No. FHWA-SA0-96-069, Golder Associates, Inc.

FHWA (1996c). *Soil Nailing Field Inspector's Manual*. Publication No. FHWA-SA0-96-069.

FHWA (1998). *Ground Improvement Technical Summaries, Final Draft*, FHWA Demonstration Project No. 116, Contract No. DTFH61-93-R-00145, Elias, V., Welsh, J., Warren J. and Lukas R.

Gazetas, G. (1982). "Shear Vibrations of Vertically Inhomogeneous Earth Dams." *International Journal for Numerical and Analytical Methods in Geomechanics*, 6(1): 219-241 (as cited in Kramer, 1996).

Gibbs, H.J. and Bara, J.P. (1967). "Stability Problems of Collapsible Soils." *Journal of the Soil Mechanics and Foundations Division, ASCE*, 93(SM4): 577-594.

Golder Associates (1996), see FHWA(1996b).

Graf, E.D. (1992a). "Compaction Grout, 1992." *Grouting, Soil Improvement and Geosynthetics, Geotechnical Special Publication No. 30*, ASCE, Vol. 1, pp. 275-287.

Graf, E.D. (1992b). "Earthquake Support Grouting in Sands." *Grouting, Soil Improvement and Geosynthetics, Geotechnical Special Publication No. 30*, ASCE, Vol. 2, pp. 879-888.

Gray, D.H. and Sotir, R. (1996). *Biotechnical and Soil Bioengineering Slope Stabilization*. John Wiley & Sons, New York, NY.

Hausmann, M.R. (1990). *Engineering Principles of Ground Modification*, McGraw-Hill, USA, 632 p.

Hayden, R.F. and Baez, J.I. (1994). "State of Practice for Liquefaction Mitigation in North America." *Proceedings of the 4th U.S.-Japan Workshop on Soil Liquefaction, Remedial Treatment of Potentially Liquefiable Soils*, PWRI, Tsukuba City, Japan, July 4-6 (as cited in ASCE, 1997).

Hayward Baker (1996). *Ground Modification Seminar Notes*. Hayward Baker, Odenton, MD.

Houston, W.H. and Houston, S.L. (1989). "State-of-the-Practice Mitigation Measures for Collapsible Soil Sites." *Foundation Engineering: Current Principles and Practices*, proceedings of the conference, edited by F.H. Kulhawy, ASCE, Vol. 1, pp. 161-175.

Hynes-Griffin, M.E. and Franklin, A.G. (1984). "Rationalizing the Seismic Coefficient Method." *Miscellaneous Paper GL-84-13*, U.S. Army Corps of Engineers Waterways Experiment Station, Vicksburg, MI, 21 p. (as cited in Kramer, 1996).

Idriss, I.M. (1990). "Response of Soft Soil Sites During Earthquakes." *Proceedings, H. Bolton Seed Memorial Symposium*, University of California, Berkeley, J.M. Duncan, ed., Bi-Tech Publishers, Vancouver, BC, Vol. 2, pp. 273-289.

Idriss, I.M. (1998). "Evaluation of Liquefaction Potential, Consequences and Mitigation, An Update." Vancouver Geotechnical Society Meeting, February 17, 1998, Vancouver, BC.

Ishihara, K. (1985). "Stability of Natural Deposits During Earthquakes." *Proceedings, 11th International Conference on Soil Mechanics and Foundation Engineering*, San Francisco, Vol. 1, pp. 321-376.

Ishihara, K. (1993). "Liquefaction and Flow Failure During Earthquakes." *Geotechnique*, 43(3): 351-415.

Ishihara, K. and Yoshimine, M. (1992). "Evaluation of Settlements in Sand Deposits Following Liquefaction During Earthquakes." *Soils and Foundations*, 32(1): 173-188.

Ishihara, K., Kokusho, T., Yasuda, S., Goto, Y., Yoshida, N., Hatanaka, M., and Ito, K. (1998). "Dynamic Properties of Masado Fill in Kobe Port Island Improved through Soil Compaction Method: Summary of Final Report by Geotechnical Research Collaboration Committee on the Hanshin-Awaji Earthquake." Geotechnical Research Collaboration Committee on the Hanshin-Awaji Earthquake, September, 1998.

Japanese Geotechnical Society (1996). *Soils and Foundations: Special Edition on Hyogoken-Nambu Earthquake*, 359 p.

Japanese Geotechnical Society (1998). *Soils and Foundations: Special Edition on Hyogoken-Nambu Earthquake*.

Karol, R.H. (1990). *Chemical Grouting*, Marcel Dekker, Inc., New York, NY, 465 p.

Kramer, S.L. (1996). *Geotechnical Earthquake Engineering*, Prentice-Hall, Inc., Upper Saddle River, NJ, 653 p.

Kulhawy, F.H. and Mayne, P.W. (1990). Manual on Estimating Soil Properties for Foundation Design, EL-6800, Research Project 1493-6, Electric Power Research Institute, Palo Alto, CA.

Ledbetter, R.H. (1985). "Improvement of Liquefiable Foundation Conditions Beneath Existing Structures." Technical Report REMR-GT-2, Dept. of the Army.

Lizzi, F. (1983). The 'reticolo di pali radice' (reticulated root piles) for the improvement of soil resistance. Physical aspects and design approaches. *Eighth European Conference on Soil Mechanics and Foundation Engineering*, Balkema, Helsinki, 8(2): 521-524.

Luehring, R. (1997). "Salmon Lake Dam Stone Column Test Section," *Technical Memorandum No. OZ-8312-6*, U.S. Dept. of the Interior, Bureau of Reclamation, Denver, CO.

Lukas (1986), see FHWA(1986a).

Makdisi, F.I. and Seed, H.B. (1978). "Simplified Procedure for Estimating Dam and Embankment Earthquake-Induced Deformations." *Journal of the Geotechnical Engineering Division, ASCE*, 104(GT7): 849-888.

Marcuson, W.F., III (1981). "Moderator's Report for Session on 'Earth Dams and Stability of Slopes Under Dynamic Loads'." *Proceedings, International Conference on Recent Advances in Geotechnical Earthquake Engineering and Soil Dynamics*, St. Louis, MO, Vol. 3, p. 1175 (as cited in Kramer, 1996).

Marcuson, W.F., III and Hynes, M.E. (1989). "Stability of Slopes and Embankments During Earthquakes." *Proceedings, ASCE/Pennsylvania Department of Transportation Geotechnical Seminar*, Hershey, PA (as cited in Kramer, 1996).

Marcuson, W.F. III, Hadala, P.F. and Ledbetter, R.H. (1993). "Seismic Rehabilitation of Earth Dams." *Geotechnical Practice in Dam Rehabilitation, Geotechnical Special Publication No. 35, Proceedings of the Specialty Conference*, Raleigh, North Carolina, Loren Anderson, ed., ASCE, pp. 430-466.

Mayne, P.W., Mitchell, J.K., Auxt, J.A., and Yilmaz, R. (1995). "U.S. National Report on CPT." *CPT '95, Proceedings of the International Symposium on Cone Penetration Testing*, Linkoping, Sweden, October, 1995.

McLean, F.G. and Hansen, K.D. (1993). "Use of Roller Compacted Concrete for Embankment Overtopping Protection." *Geotechnical Practice in Dam Rehabilitation, Geotechnical Special Publication No. 35, Proceedings of the Specialty Conference*, Raleigh, North Carolina, Loren Anderson, ed., ASCE, pp. 188-209.

Mitchell, J.K. (1976). "Stabilization of Soils for Foundation of Structures." Department of Civil Engineering, University of California, Berkeley.

Mitchell, J.K. (1981). "Soil Improvement: State-of-the-Art." State-of-the-Art Report, Session 12, *10th International Conference on Soil Mechanics and Foundation Engineering*, Stockholm, Sweden.

Mitchell, J.K. (1993). *Fundamentals of Soil Behavior*, John Wiley & Sons, Inc., New York, NY, 2nd edition, 437 p.

Mitchell, J.K. and Christopher, B.R. (1990). "North American Practice in Reinforced Soil Systems." *Proceedings of a Conference, Design and Performance of Earth Retaining Structures*, June 1990, ASCE Geotechnical Special Publication No. 25, pp. 322-246.

Mitchell, J.K. and Cooke, H.G. (1995). "Assessment and Mitigation of Liquefaction Risk for Existing Bridge Foundations." *Proceedings of the National Seismic Conference on Bridges and Highways*, San Diego, CA.

- Mitchell, J.K., Baxter, C.D.P., and Munson, T.C. (1995). "Performance of Improved Ground During Earthquakes." *Soil Improvement for Earthquake Hazard Mitigation*, Geotechnical Special Publication No. 49, ASCE, pp. 1-36.
- Mitchell, J.K., Cooke, H.G., and Schaeffer, J.A. (1998). "Design Considerations in Ground Improvement for Seismic Risk Mitigation." *Geotechnical Earthquake Engineering and Soil Dynamics III*, Geotechnical Special Publication No. 75, ASCE, Vol. 1, pp. 580-613.
- Naesgaard, E., Byrne, P.M., Ven Huizen, G. (1998). "Behaviour of Light Structures Founded on Soil 'Crust' Over Liquefied Ground." *Geotechnical Earthquake Engineering and Soil Dynamics III*, Geotechnical Special Publication No. 75, edited by P. Dakoulas, M. Yegian, and R.D. Holtz, ASCE, Vol. 1, pp. 422-433.
- Narin van Court, W.A. and Mitchell, J.K. (1994). "Soil Improvement by Blasting." *Journal of Explosives Engineering*, Vol. 12, No. 3, pp.34-41, Nov./Dec. 1994.
- Narin van Court, W.A. and Mitchell, J.K. (1995). "Soil Improvement by Blasting: Part II." *Journal of Explosives Engineering*, Vol. 12, No. 4, pp. 26-34, Jan./Feb. 1995.
- NAVFAC (1982). *Soil Mechanics, NAVFAC Design Manual 7.1*, Department of the Navy, Naval Facilities Engineering Command, Alexandria, Virginia.
- NCEER (1997), *Proceedings of the NCEER Workshop on Evaluation of Liquefaction Resistance of Soils*, Technical Report NCEER-97-0022, edited by T.L. Youd and I.M. Idriss, National Center for Earthquake Engineering Research, Buffalo, NY.
- Newmark, N.M. (1965). "Effects of Earthquakes on Dams and Embankments." *Geotechnique*, 15(2): 139-160.
- Onoue, A. (1988). "Diagrams Considering Well Resistance for Designing Spacing Ratio of Gravel Drains." *Soils and Foundations*, 29(4): 135-136.
- Portland Cement Association (1992). *RCC Newsletter*, Fall/Winter 1992, Skokie, IL.
- Portland Cement Association (1997). *RCC Newsletter*, Spring/Summer 1997, Skokie, IL.
- Robertson, P. K. and Campanella, R. G. (1983a). "Interpretation of Cone Penetration Tests. Part I: Sand." *Canadian Geotechnical Journal*, 20(4): 718-733.
- Robertson, P. K. and Campanella, R. G. (1983b). "Interpretation of Cone Penetration Tests. Part II: Clay." *Canadian Geotechnical Journal*, 20(4): 734-745.
- Roller Compacted Concrete II* (1988), Proceedings of the Conference sponsored by the Construction, Geotechnical Engineering, and Materials Engineering Divisions of ASCE, San Diego, California, Feb./Mar. 1988, K.D. Hansen and L.K. Guice, eds., ASCE.

Roller Compacted Concrete III (1992), Proceedings of the Conference sponsored by the Construction, Geotechnical Engineering, and Materials Engineering Divisions of ASCE, San Diego, California, February 1992, K.D. Hansen and F.G. McLean, eds., ASCE.

Seed, H.B. (1979a). "Considerations in the Earthquake-Resistant Design of Earth and Rock-fill Dams." 19th Rankine Lecture of the British Geotechnical Society, *Geotechnique*, 29(3): 215-263.

Seed, H.B. (1979b). "Soil Liquefaction and Cyclic Mobility Evaluation for Level Ground During Earthquakes." *Journal of the Geotechnical Engineering Division*, ASCE, 105(GT2): 201-255.

Seed, H.B. and Booker, J.R. (1977). "Stabilization of Potentially Liquefiable Sand Deposits Using Gravel Drains." *Journal of the Geotechnical Engineering Division*, ASCE, 103(GT7), 757-768.

Seed, R.B. and Harder, L.F. (1990). "SPT-based Analysis of Cyclic Pore Pressure Generation and Undrained Residual Strength." *Proceedings, H. Bolton Seed Memorial Symposium*, University of California, Berkeley, J.M. Duncan, ed., Bi-Tech Publishers, Vancouver, BC, Vol. 2, pp. 351-376.

Seed, H.B., Tokimatsu, K., Harder, L.F. and Chung, R.M. (1984). *The Influence of SPT Procedures on Soil Liquefaction Resistance Evaluations*. Report No. UCB/EERC-84/15, Earthquake Engineering Research Center, University of California, Berkeley, October.

Sherard, J.L., Dunnigan, L.P. and Decker, R.S. (1976). "Identification and Nature of Dispersive Soils, *Journal of the Geotechnical Engineering Division*, ASCE, Vol. 102, No. GT-4, pp. 287-301.

Taki, O. and Yang, D. S. (1991). Soil-cement mixed wall technique. *Geotechnical Engineering Congress 1991*, Geotechnical Special Publication No. 27, ASCE, Vol. 1, pp. 298-309.

Terzaghi, K. (1950). "Mechanisms of Landslides." *Engineering Geology (Berkey) Volume*, Geological Society of America (as cited in Kramer, 1996).

Terzaghi, K., Peck, R.B., and Mesri, G. (1995). *Soil Mechanics in Engineering Practice*, John Wiley & Sons, New York, NY, 3rd edition, 549 p.

Tokimatsu, K. and Seed, H.B. (1987). "Evaluation of Settlements in Sand Due to Earthquake Shaking." *Journal of Geotechnical Engineering*, ASCE, 113(8): 861-878.

USDA Soil Conservation Service (1992). "Soil Bioengineering for Upland Slope Protection and Erosion Reduction." Chapter 18, Part 650, 210-EFH, *Field Handbook*, 53 p. (as cited in ASCE, 1997).

U.S. Department of the Interior, Bureau of Reclamation (1987). *Design of Small Dams*.

Vucetic, M. and Dobry, R. (1991). "Effect of Soil Plasticity on Cyclic Response." *Journal of Geotechnical Engineering*, ASCE, 117(1): 89-107.

Walkinshaw, J.L. and Chassie, R.J. (1994). "Implementation of Soil-Nailing Technologies in the United States." TR News 172. Transportation Research Board, Washington, DC.

Walz, A.H., Jr. (1993). "Inspections, Evaluations and Modifications for Corps of Engineers Dams." *Geotechnical Practice in Dam Rehabilitation, Geotechnical Special Publication No. 35*, Proceedings of the Specialty Conference, Raleigh, North Carolina, ASCE, pp. 35-42.

Warner, J., Schmidt, N., Reed, J. Shepardson, D., Lamb, R. and Wong, S. (1992). "Recent Advances in Compaction Grouting." *Grouting, Soil Improvement and Geosynthetics, Geotechnical Special Publication No. 30*, ASCE, Vol. 1, pp. 252-264.

Wray, W.K., ed. (1995). *So Your Home Is Built on Expansive Soils: A Discussion of How Expansive Soils Affect Buildings*. Shallow Foundation Committee of the Geotechnical Division of ASCE, 59 p.

Xanthakos, P.P., Abramson, L.W. and Bruce, D.A. (1994). *Ground Control and Improvement*, John Wiley & Sons, New York, NY, 910 p.

Yasuda, S., Ishihara, K., Harada, K., Shinkawa, N. (1996). "Effectiveness of the Ground Improvement on the Susceptibility of Liquefaction Observed During the 1995 Hyogo-ken Nambu (Kobe) Earthquake." *World Conference on Earthquake Engineering*, Mexico.

Youd, T.L. and Garris, C.T. (1995). "Liquefaction-Induced Ground-Surface Disruption." *Journal of Geotechnical Engineering*, Technical Note, ASCE, 121(11): 805-809.

Youd, T.L. and Gummow, G.A. (1995). *Screening Guide for Rapid Assessment of Liquefaction Hazard to Highway Bridges*." Draft, NCEER Project No. 106, 1995.

<p>CECW-EG Engineer Technical Letter 1110-1-185</p>	<p>Department of the Army U.S. Army Corps of Engineers Washington, DC 20314-1000</p>	<p>ETL 1110-1-185 1 February 1999</p>
	<p>EXPIRES 31 December 2003 Engineering and Design GUIDELINES ON GROUND IMPROVEMENT FOR STRUCTURES AND FACILITIES</p>	
	<p>Distribution Restriction Statement Approved for public release; distribution is unlimited.</p>	